



HPV Closed Loop Pump Data and Specifications



Specifications

		HPV 55		HPV 75		HPV 105		HPV 135	
cm ³ /rev	in ³ /rev	55	3.35	75	4.57	105	6.40	135	8.23
Pressure Ratings		Nominal 5000 PSIG		Maximum 6090 PSIG		Peak 7250 PSIG			
Rated Speed Max Disp		3500		3200		2800		2600	
Rated Speed Min Disp		Contact Factory							
Envelope Size: Length		10.7		11.5		12.4		14.4	
Width		11.5		12.2		13.8		13.9	
Height		10.5		11.2		11.5		12.0	
Weight		76.0		95.0		128.0		165.0	
HP Rating Count		107.0		135.0		164.0		196.0	

HPV Closed Loop Pump Mechanical-hydraulic Control (cam plate feature)

Circuit Diagram

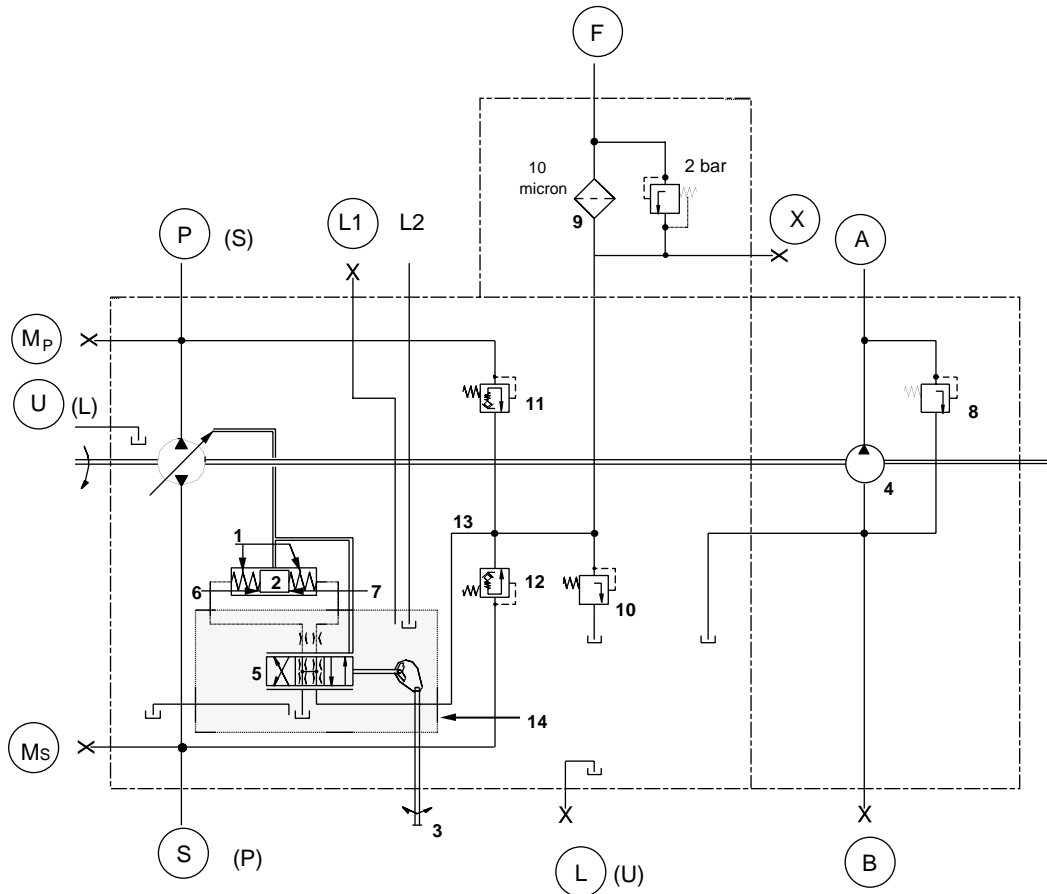

EXPLANATIONS	
P, S	High pressure port
A	Pressure port boost pump
B	Suction port boost pump
F	Control pressure supply, Boost
X	Control pressure gauge port
Ms, Mp	High pressure gauge port
L, U	Drain (filling, vent) ports and flushing return from hydraulic motor
L1, L2	Vent ports

HPV Closed Loop Pump Mechanical-hydraulic Control (cam plate feature)

Description

Type HPV - 02 variable pumps are axial piston pumps of swash plate design with variable displacement for hydrostatic transmissions (HST) in closed loop applications.

The HPV - 02 pump described in this report is equipped with an M1 type cam control. All auxiliary features for closed loop are integrated in or attached to the pump:

- **Servo control M1:** can be mounted on or taken off without interfering with the main pump.
- **Ancillary pump:**
 - inner ring gear pump for one sense of rotation, internal suction; without interfering with the main pump, the ancillary pump can be put on or off.
 - suction side is screen protected.
 - provides control pressure for the swash plate.
 - leakage from the closed loop is restituted with a defined preload.
- **Cold start valve:** protects the cooler; responds only when back pressure in the cooling or filtration circuit exceeds the set level. Its setting is always higher than that of the boost pressure relief valve.
- **Boost pressure relief valve:** limits the maximum control and boost pressure.
- **Combined high pressure relief and boost check valves:**
 - relief valves limit the maximum working pressure in the high pressure line.
 - boost check valves are for make up in the closed loop circuit (to replace leakage losses) .
- **Cartridge filter:** 10 micron replacement cartridge filter. The entire flow of the ancillary pump passes through this filter.

HPV Closed Loop Pump

Mechanical-hydraulic Control (cam plate feature)

Function

- 1. Mechanical zero position**
- 2. Hydraulic zero position**
- 3. Boost and high pressure circuit**
- 4. Servo control M1**
- 5. Pressure relief valve**
- 6. Ancillary pump**

1. Mechanical zero position

As long as the HPV pump is not driven by the prime mover, it is held in neutral position by mechanical means.

The swash plate (item 2 in the circuit diagram) is positively held in its no-flow position by two springs (1) at the control pistons, so that at the moment of starting, the pump runs without displacement.

Precondition: the actuation lever (3) has not been offset.

This mechanical setting of the zero position is done during assembly in the factory and cannot be altered from outside.

2. Hydraulic zero position

When the pump is driven, it is held in neutral by hydraulic means:

boost pressure coming through channel (13) to the pilot (5) of the servo control acts here as a control pressure. In its central position, the pilot (5) relates both control pistons (6+7) to the control pressure, so that they keep the swash plate in neutral.

Precondition: the actuation lever (3) must not be in an offset position!

The hydraulic tuning of zero position is done at the Linde test center. It may be changed only in exceptional cases by trained experts. The corresponding service information must be adhered to.

HPV Closed Loop Pump

Mechanical-hydraulic Control (cam plate feature)

Function

3. Boost and high pressure circuit

In the swash plate's neutral position, there is no axial stroking of the pistons and therefore no pump delivery.

The pump shaft drives not only the rotating group of the main pump, but also the ancillary pump (4). This sucks hydraulic oil from inside the pump housing and sends it on a trip from port A (see circuit diagram) to a cooler (if available) and back into the HPV pump at port F. The cold start valve (8) responds only if back pressure in the cooling and filtration circuit exceeds the set value. The entire flow runs through the 10 micron cartridge filter (9). Back in the pump, the oil passes the two boosting valves (combined valves 11+12), flows on to the two high pressure ports (P+S) and then to the servo control (14).

The excess oil not required to make up for leakage losses bleeds off at the boost pressure relief valve (10). This maintains the set boost pressure for the low pressure return side of the main circuit.

Depending on the direction of swash plate tilt, either port P or S carries high pressure, at the same time closing the respective boost valve (11 or 12). Boost oil can only be fed in on the low pressure side.

If high pressure exceeds the set maximum value of the combined boost and high pressure relief valve, the surplus spills over through the connecting channel to the opposite boost valve and into the low pressure line.

4. Servo control M1

The "cam type hydraulic servo control" features a pilot valve integrated in the control device (14). Control of the swash plate is realized by one control piston on each side (see circuit diagram 1/9, item 6+7 and function drawing 9/9).

The pilot valve (5) is offset from its neutral position to one or the other side by means of control shaft and cam, depending on which side the control lever has been moved to. This directs control pressure to the corresponding piston (6 or 7) and relieves the other. The swash plate leaves its neutral position. When it reaches the desired position preselected with the control lever, the pilot valve (5) equally connects the control pistons (6+7) to pressure, and the swash plate stops. Every position of the control lever relates to a respective position of the swash plate.

The characteristic of the cam plate is progressive, with extended neutral. This allows for particularly sensitive tilting during start and stop.

HPV Closed Loop Pump Mechanical-hydraulic Control (cam plate feature)

Functional Description

5. Pressure relief valves

5.1 Boost pressure and cold start valve DBE 6 fig.1&2 (8 and10)

The pressure relief valves DBE 6 fitted in the HPV and its auxiliary pump are spring-loaded conical seat type. They consist of valve body, plug (and setting screw, fig. 2, for cold start valve) compression spring and valve poppet, which is forced down on its seat.

The boost pressure valve is factory-set. The spring force can be varied by means of appropriate springs and shims, in order to adjust the response pressure to the required level of pressure limitation.

Response pressure of the cold start valve (fig.2) can be changed by some ± 5 bar by means of a hex head screw.

Both valves must be fastened with the prescribed locking torque.

Sealing is realized by cutting edge on the bottom and by O ring on the top.

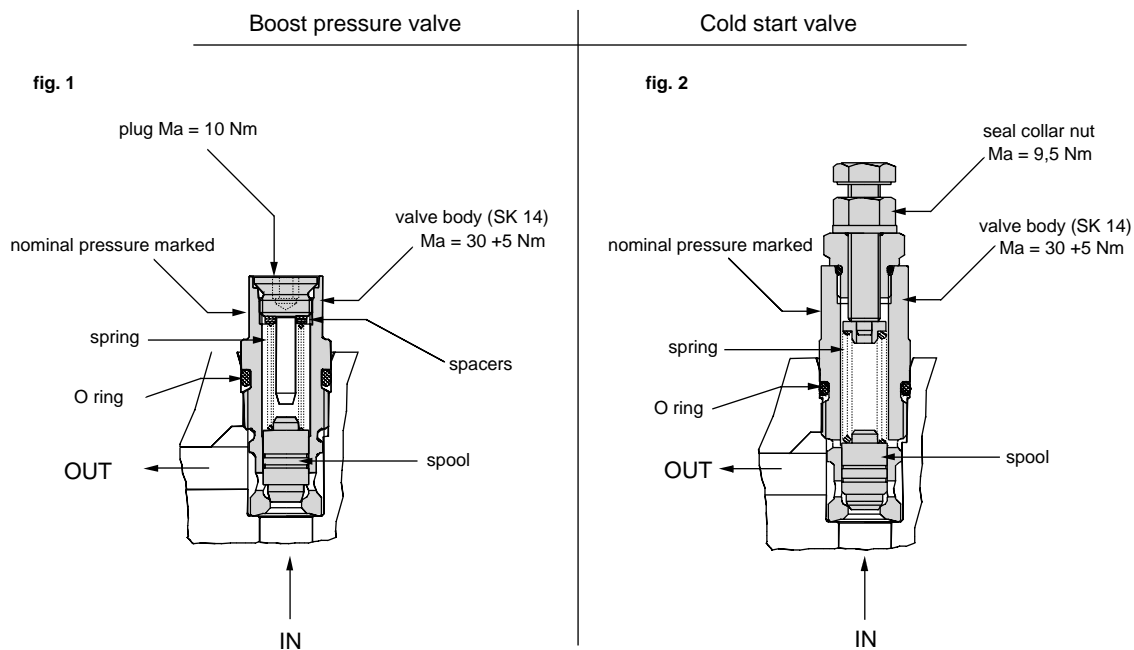

HPV Closed Loop Pump Mechanical-hydraulic Control (cam plate feature)

Functional Description

5.2 Combined pressure relief and make-up valves VD 12 (11) and (12)

The VD12 valve cartridges screwed into the HPV valve plate housing are factory-set, direct acting pressure relief valves with make-up function. They consist of valve body, plug, spring 1, spring 2, snap ring, spring plate and valve spool. The setting is not adjustable. For other pressure settings, the VD12 valve has to be exchanged as a whole.

5.2.1 Function as boost valve (make-up)

There is always pressure in the F line (boost pressure). Should pressure in channel P/S be lower than in channel F, pressure in chamber F, due to the differential pressure, acts on the effective area of the check valve poppet, which is thereby shifted against the force of spring 2 and connects channel F with P/S. Pressures are balanced off, thus avoiding cavitation.

5.2.2 Function as pressure relief valve

When high pressure in channel P/S, acting on area D of the valve spool, reaches the setting of spring 1, the spool moves against the force of the spring. Connection to channel P/S is established, and pressure can be relieved.

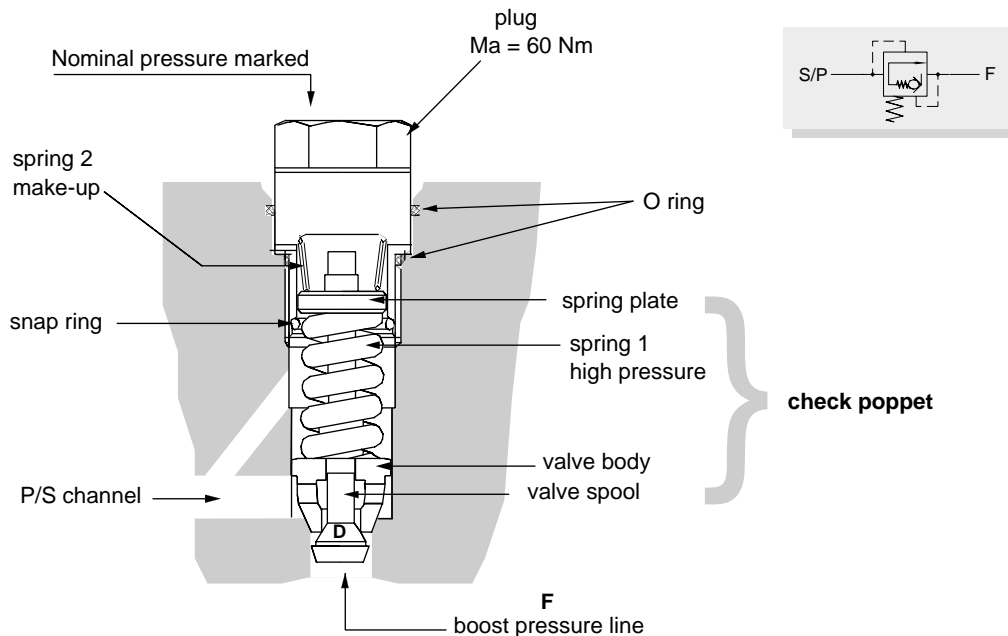

HPV Closed Loop Pump Mechanical-hydraulic Control (cam plate feature)

Basic Design of Rotating Group

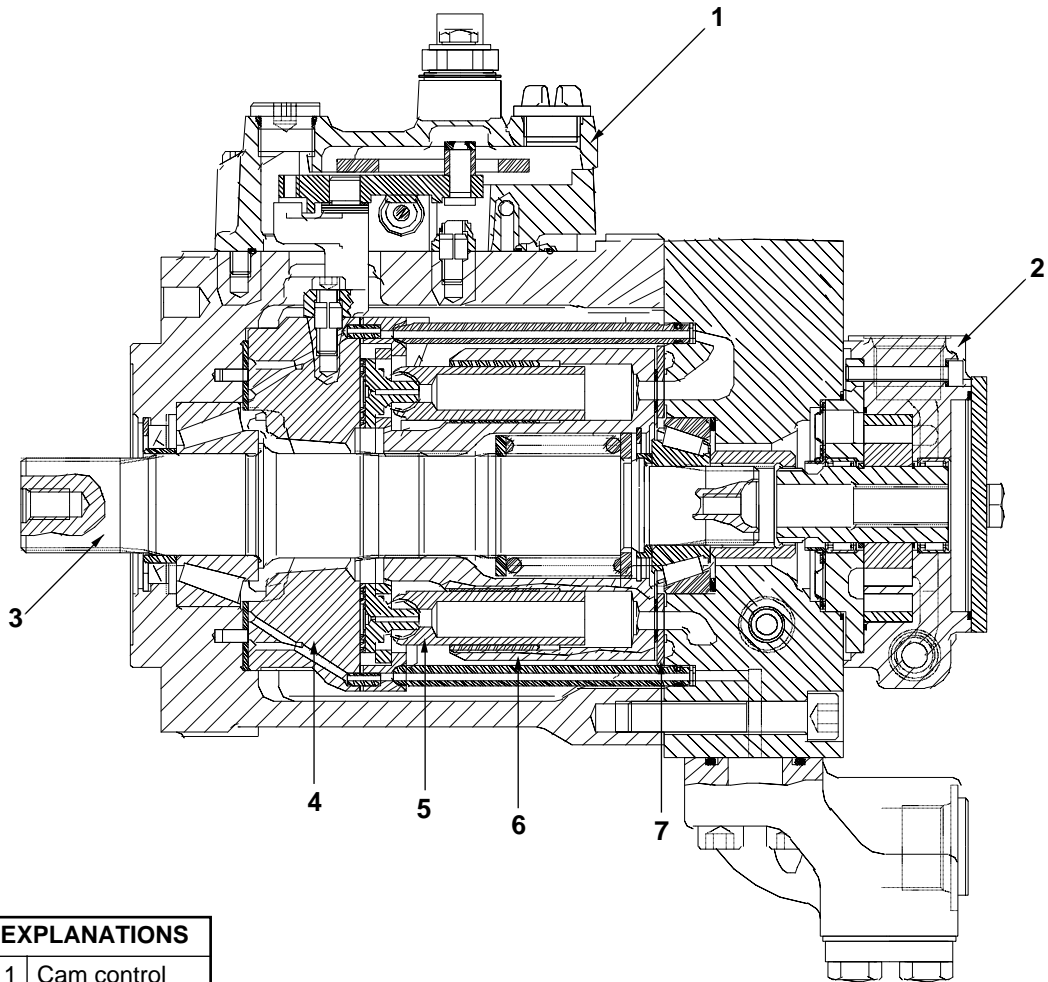

EXPLANATIONS	
1	Cam control
2	Gear pump
3	Shaft
4	Swash plate
5	Working piston
6	Cylinder barrel
7	Port plate

HPV Closed Loop Pump E1 Electro-hydraulic Control

Circuit Diagram

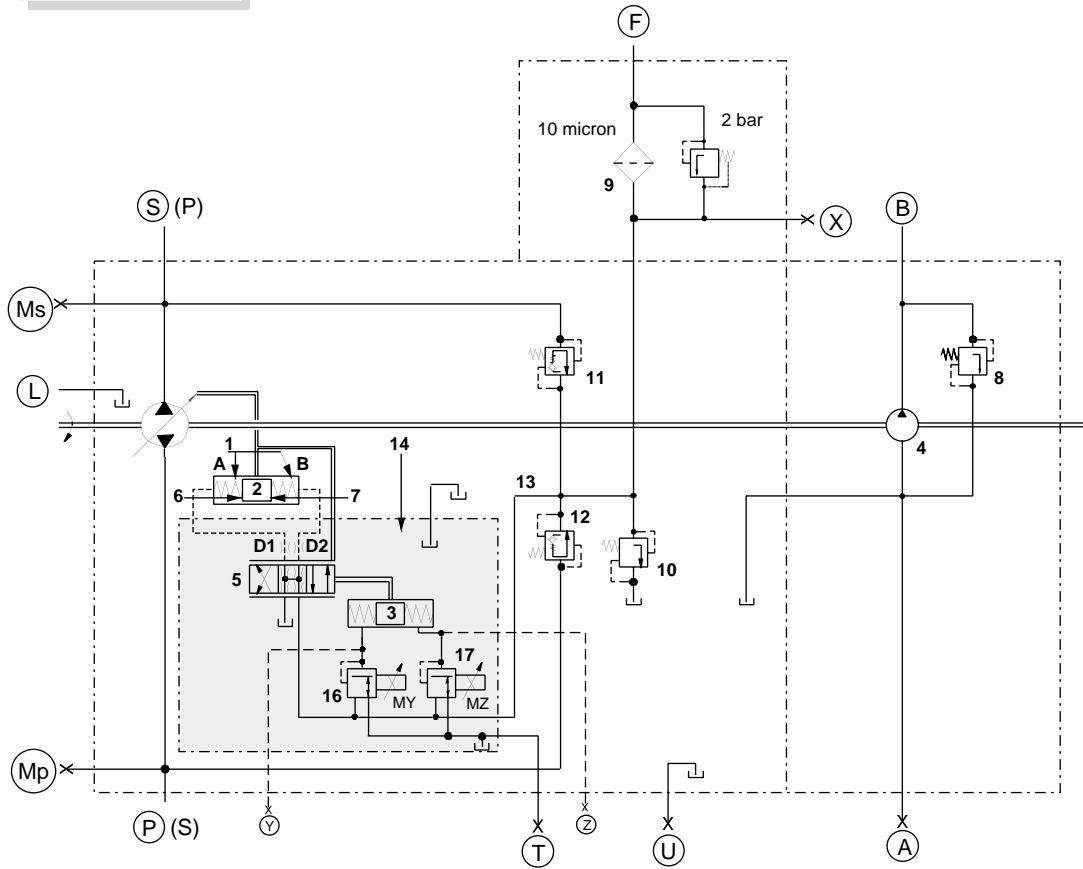

EXPLANATIONS	
P, S	High pressure port
B	Pressure port boost pump
A	Suction port boost pump
F	Control and boost pressure supply
T	Tank and vent port
X	Boost pressure gauge port
Y, Z	Control pressure gauge port
MY, MZ	Proportional solenoid 12V
Ms, Mp	High pressure gauge port
U	Drain, flushing return from hydraulic motor
L	Oil filling, tank and vent port

solenoid My energized » HP pressure in port S
solenoid Mz energized » HP pressure in port P

Displacement Relative to Control Current

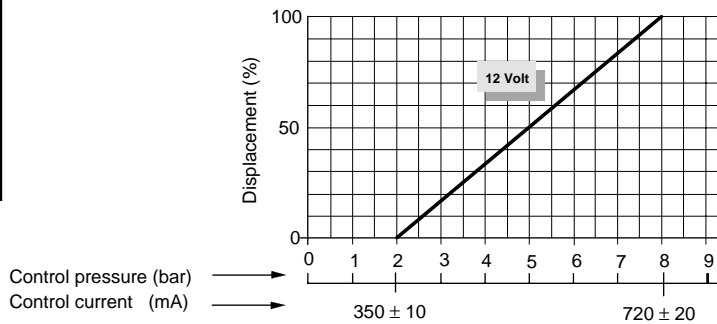

HPV Closed Loop Pump E1 Electro-hydraulic Control

Description

Type HPV - 02 variable pumps are axial piston pumps of swash plate design with variable displacement for hydrostatic transmissions (HST) in closed loop applications.

The HPV - 02 pump described in this report is equipped with an E1 type electro-hydraulic control.

All auxiliary features for closed loop are integrated in or attached to the pump:

- **Servo control E1:** can be mounted on or taken off without interfering with the main pump.
- **Ancillary pump:**
 - inner ring gear pump for one sense of rotation, internal suction; without interfering with the main pump, the ancillary pump can be put on or off.
 - suction side is screen-protected.
 - provides control pressure for the swash plate.
 - leakage from the closed loop is restituted with a defined preload.
- **Cold start valve:** protects the cooler; responds only when back pressure in the cooling or filtration circuit exceeds the set level. Its setting is always higher than that of the boost pressure relief valve.
- **Boost pressure relief valve:** limits the maximum control and boost pressure.
- **Combined high pressure relief and boost check valves:**
 - relief valves limit the maximum working pressure in the high pressure line.
 - boost check valves are for make up in the closed loop circuit (to replace leakage losses).
- **Cartridge filter:** 10 micron replacement cartridge filter. The entire flow of the ancillary pump passes through this filter.

HPV Closed Loop Pump

E₁ Electro-hydraulic Control

Functional Description

- 1. Mechanical zero position**
- 2. Hydraulic zero position**
- 3. Boost and high pressure circuit**
- 4. Servo control E1**
- 5. Pressure relief valve**
- 6. Ancillary pump**

1. Mechanical zero position

As long as the HPV pump is not driven by the prime mover, it is held in neutral position by mechanical means.

The swash plate (item 2 in the circuit diagram) is positively held in its no-flow position by two springs (1) at the displacement pistons, so that at the moment of starting, the pump runs without displacement.

Precondition: the proportional solenoids (My and Mz) are not energized.

This mechanical setting of the zero position is done during assembly in the factory and cannot be altered from outside.

2. Hydraulic zero position

When the pump is driven, it is held in neutral by hydraulic means.

Precondition: proportional solenoids (My and Mz) are not energized.

Boost pressure reaching the servo control device E1 via channel 13 acts as a control pressure.

In its central position, pilot valve (5) connects both displacement pistons (6) and (7) with the control pressure, thus keeping the swash plate in its neutral position.

The hydraulic tuning of zero position is done at Linde's test center. It may be changed only in exceptional cases by trained experts. The corresponding service information must be adhered to.

HPV Closed Loop Pump

E₁ Electro-hydraulic Control

Functional Description

3. Boost and high pressure circuit

In swash plate's neutral position, there is no axial stroking of the pistons and therefore, no pump delivery.

The pump shaft drives not only the rotating group of the main pump but also the ancillary pump (4). This sucks hydraulic oil from inside the pump housing and sends it on a trip from port A (see circuit diagram) to a cooler (if available) and back into the HPV pump at port F. The cold start valve (8) responds only if back pressure in the cooling and filtration circuit exceeds the set value. The entire flow runs through the 10 micron cartridge filter (9). Back in the pump, the oil passes the two boosting valves (combined valves 11+12), flows on to the two high pressure ports (P+S) and then to the servo control (14).

The excess oil not required to make up for leakage losses bleeds off at the boost pressure relief valve (10). This maintains the set boost pressure for the low pressure return side of the main circuit.

Depending on the direction of swash plate tilt, either port P or S carries high pressure, at the same time closing the respective boost valve (11 or 12). Boost oil can only be fed in on the low pressure side.

If high pressure exceeds the set maximum value of the combined boost and high pressure relief valve, the surplus spills over through the connecting channel to the opposite boost valve and into the low pressure line.

4. Servo control E1

The "electro-hydraulic servo control" uses for its actuation a pilot valve (5) integrated in the servo device (15).

The pilot valve (5) is moved by means of the actuation piston (3), which normally is accurately held in its middle position by two springs. Pilot valve (5) and actuating piston (3) are mechanically linked to each other by a lever (see functional schema E1). Control of the actuating piston (3) is realized with a control pressure selected at the solenoid (My or Mz), which determines both amount and direction of pump flow.

HPV Closed Loop Pump

E₁ Electro-hydraulic Control

Functional Description

How the control device works:

It is supposed that the proportional solenoids (My and Mz) are not actuated.

If the HPV is driven, there is boost pressure in channel (13). The boost pressure (control pressure) present in the servo E1 travels to channel (13) up to the un-powered proportional valves (16) and (17).

The HPV is in its hydraulic zero position (see description item 2).

If a current is induced by the electronics flows in the proportional solenoid (My), this generates a proportional magnetic force F_m at the pin of the solenoid. In the subsequent proportional valve (16), a pressure F_h is sent to the actuation piston (3), which corresponds to the solenoid signal. The actuation piston (3) shifts accordingly; fluid on the opposite side is discharged to tank via the proportional valve (17); the pilot valve (5) is moved and supplies control pressure to the control piston (6); control piston (7) is relieved to tank; and the pump (swash plate) (2) tilts in the corresponding direction.

If the signal (F_m) at the solenoid (My) is lessened, the proportional valve (16) reduces the pressure towards actuation piston (3) and the swash angle becomes smaller.

Diagram

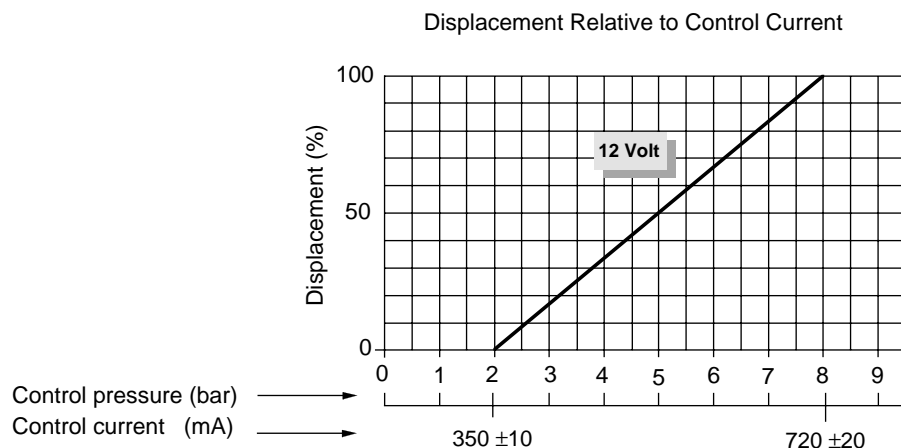

HPV Closed Loop Pump E₁ Electro-hydraulic Control

Functional Description

5. Pressure relief valves

5.1 Boost pressure and cold start valve DBE 6 (8 and 10)

The pressure relief valves DBE 6 fitted in the HPV 55 - 02 and its auxiliary pump are factory-set, spring-loaded conical seat ones. They consist of valve body, compression spring and valve poppet, which is forced down on its seat.

The spring force can be varied by means of appropriate springs and shims in order to adjust the response pressure to the required level of pressure limitation. The complete valve must be fastened with the prescribed locking torque.

The bodies of the two valves are not identical (see fig.1). They must not be interchanged to avoid malfunction. Sealing is realized by cutting edge on the bottom and by O ring on the top.

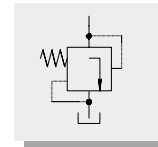
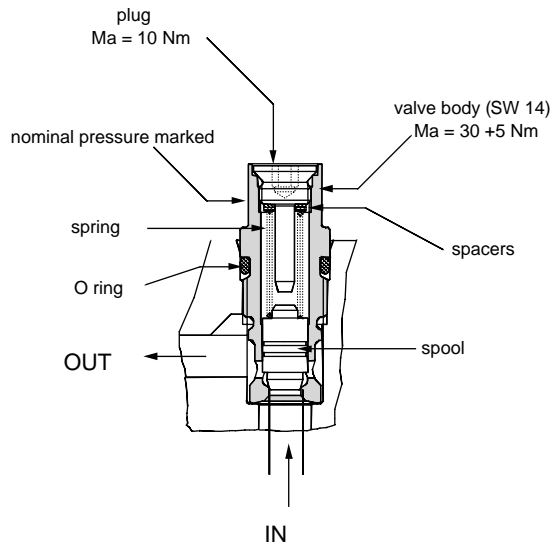
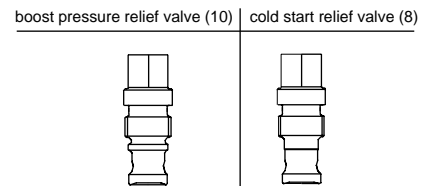

Fig. 1



HPV Closed Loop Pump

E₁ Electro-hydraulic Control

Functional Description

5.2 Combined pressure relief and make-up valves VD 9 (11) and (12)

The VD9 valve cartridges screwed into the HPV-55 valve plate housing are factory-set, direct acting pressure relief valves with make-up function. They consist of valve body, plug, spring 1, spring 2, snap ring, spring plate and valve spool. The setting is not adjustable. For other pressure settings, the VD9 valve has to be exchanged as a whole.

5.2.1 Function as boost valve (make up)

There is always pressure in the F line (boost pressure). Should pressure in channel P/S be lower than in channel F, pressure in chamber F, due to the differential pressure, acts on the effective area of the check valve poppet, which is thereby shifted against the force of spring 2 and connects channel F with P/S. Pressures are balanced off, thus avoiding cavitation.

5.2.2 Function as pressure relief valve

When high pressure in channel P/S, acting on area D of the valve spool, reaches the setting of spring 1, the spool moves against the force of the spring. Connection to channel P/S is established, and pressure can be relieved.

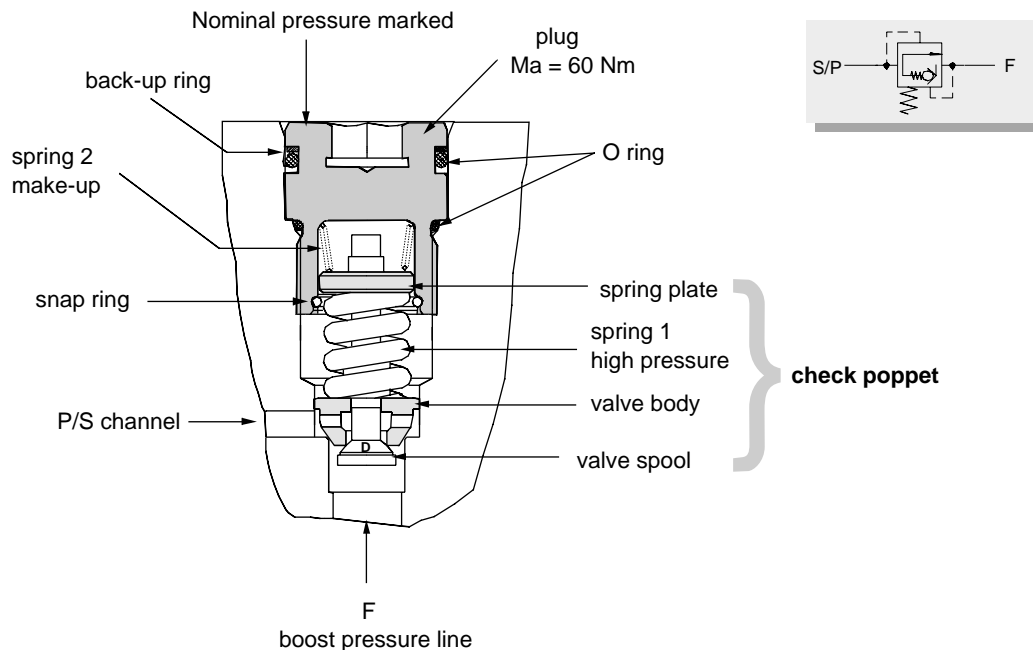

HPV Closed Loop Pump

E₁ Electro-hydraulic Control

Basic Design of Rotating Group

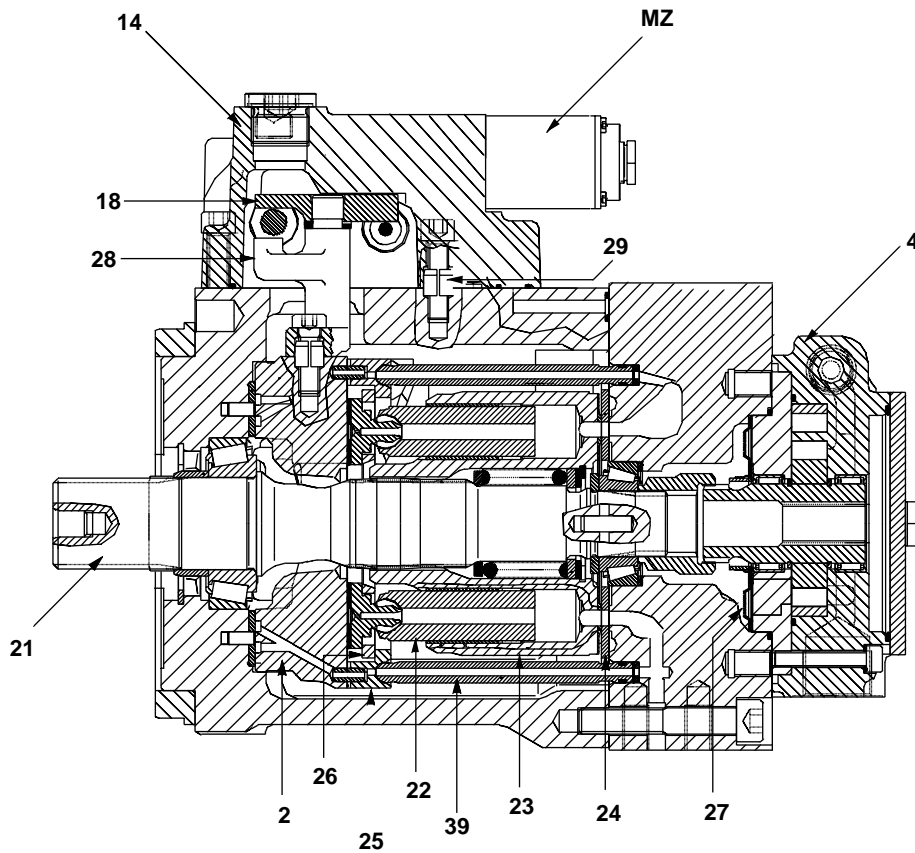

EXPLANATIONS	
2	Swash plate
4	Ancillary pump
14	Electro-hydraulic control E1
18	Link
21	Shaft
22	Working piston
23	Cylinder barrel
24	Port plate
25	Holding clamp
26	Retainer plate
27	Screen
28	Feed back lever
29	Dowel (centering of control E1)
39	Tube

HPV Closed Loop Pump

E₁ Electro-hydraulic Control and PCO

Circuit Diagram

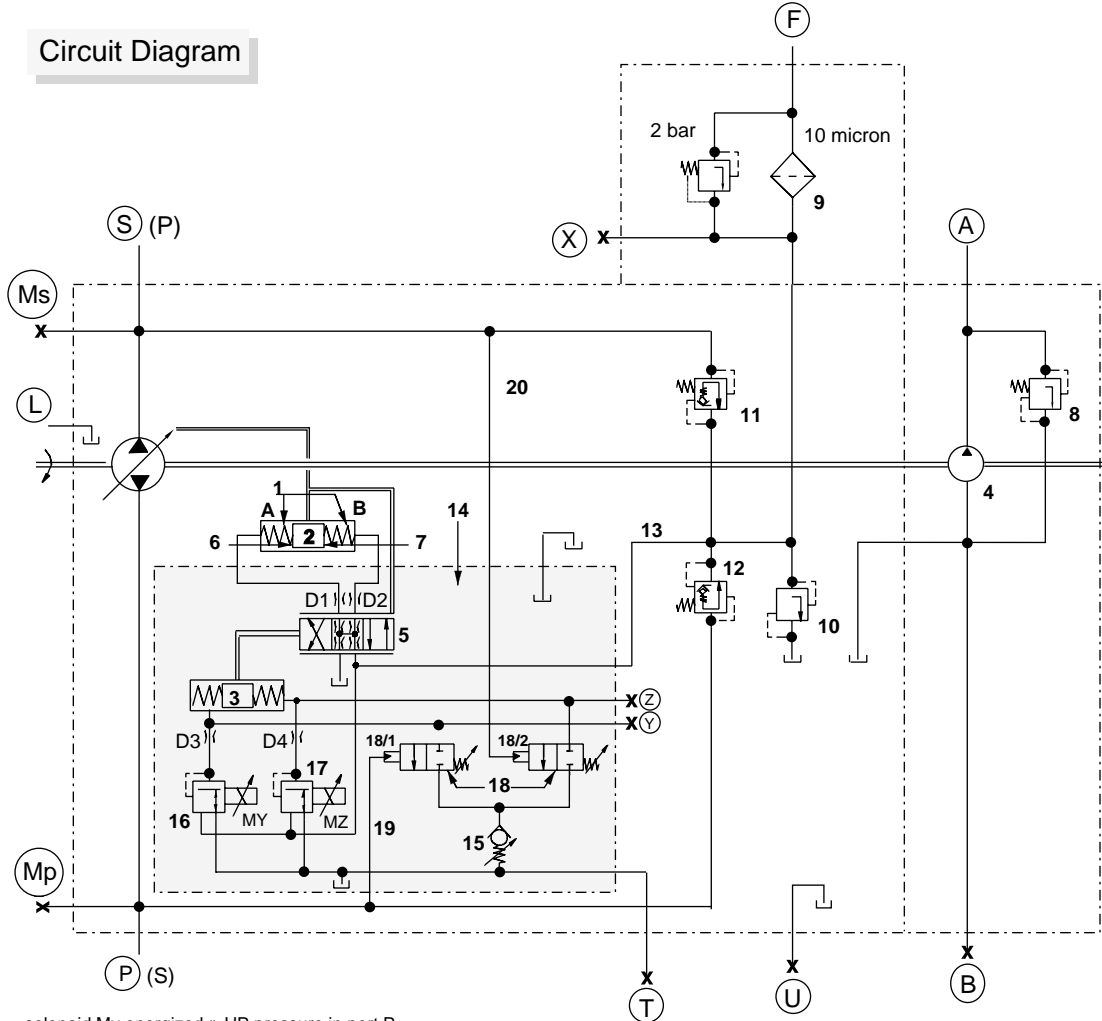

solenoid My energized » HP pressure in port P
 solenoid Mz energized » HP pressure in port S

Displacement Relative to Control Current
 below regulation beginning of pressure cut-off

EXPLANATIONS	
P, S	High pressure port
B	Suction port boost pump
A	Pressure port boost pump
F	Control and boost pressure supply
T	Tank and vent port
X	Boost pressure gauge port
Y, Z	Control pressure gauge port
MY, MZ	Proportional solenoid 24V
Ms, Mp	High pressure gauge port
U	Drain, flushing return from hydraulic motor
L	Oil filling, tank and vent port

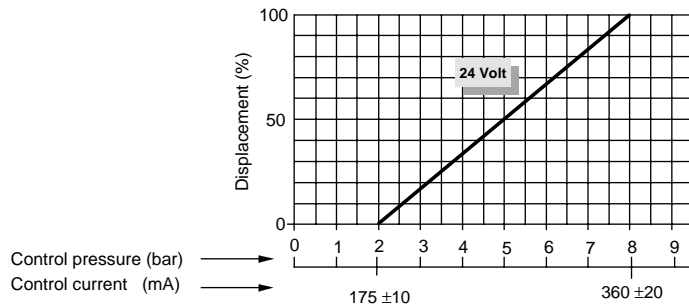

HPV Closed Loop Pump

E₁ Electro-hydraulic Control and PCO

Description

Type HPV - 02 variable pumps are axial piston pumps of swash plate design with variable displacement for hydrostatic transmissions (HST) in closed loop applications.

The HPV - 02 pump described in this report is equipped with an E1P type electro-hydraulic control.

All auxiliary features for closed loop are integrated in or attached to the pump:

- **Servo control E1P:** can be mounted on or taken off without interfering with the main pump.
- **Ancillary pump:**
 - inner ring gear pump for one sense of rotation, internal suction; without interfering with the main pump, the ancillary pump can be put on or off.
 - suction side is screen-protected.
 - provides control pressure for the swash plate.
 - leakage from the closed loop is restituted with a defined preload.
- **Cold start valve:** protects the cooler; responds only when back pressure in the cooling or filtration circuit exceeds the set level. Its setting is always higher than that of the boost pressure relief valve.
- **Boost pressure relief valve:** limits the maximum control and boost pressure.
- **Combined high pressure relief and boost check valves:**
 - relief valves limit the maximum working pressure in the high pressure line.
 - boost check valves are for make-up in the closed loop circuit (to replace leakage losses) .
- **Cartridge filter:** 10 micron replacement cartridge filter. The entire flow of the ancillary pump passes through this filter.

HPV Closed Loop Pump

E₁ Electro-hydraulic Control and PCO

Functional Description

- 1. Mechanical zero position**
- 2. Hydraulic zero position**
- 3. Boost and high pressure circuit**
- 4. Servo control E1P**
- 5. Pressure relief valve**
- 6. Ancillary pump**

1. Mechanical zero position

As long as the HPV pump is not driven by the prime mover, it is held in neutral position by mechanical means.

The swash plate (item 2 in the circuit diagram) is positively held in its no-flow position by two springs (1) at the displacement pistons, so that at the moment of starting, the pump runs without displacement.

Precondition: the proportional solenoids (My and Mz) are not energized.

This mechanical setting of the zero position is done during assembly in the factory and cannot be altered from outside.

2. Hydraulic zero position

When the pump is driven, it is held in neutral by hydraulic means.

Precondition: proportional solenoids (My and Mz) are not energized.

Boost pressure reaching the servo control device E1P via channel 13 acts as a control pressure.

In its central position, pilot valve (5) connects both displacement pistons (6 and 7) with the control pressure, thus keeping the swash plate in its neutral position.

The hydraulic tuning of zero position is done at Linde's test center. It may be changed only in exceptional cases by trained experts. The corresponding service information must be adhered to.

HPV Closed Loop Pump

E₁ Electro-hydraulic Control and PCO

Functional Description

3. Boost and high pressure circuit

In the swash plate's neutral position, there is no axial stroking of the pistons and therefore, no pump delivery.

The pump shaft drives not only the rotating group of the main pump but also the ancillary pump (4). This sucks hydraulic oil from inside the pump housing and sends it on a trip from port A (see circuit diagram) to a cooler (if available) and back into the HPV pump at port F. The cold start valve (8) responds only if back pressure in the cooling and filtration circuit exceeds the set value. The entire flow runs through the 10 micron cartridge filter (9). Back in the pump, the oil passes the two boosting valves (combined valves 11+12), flows on to the two high pressure ports (P+S) and then to the servo control (14).

The excess oil not required to make up for leakage losses bleeds off at the boost pressure relief valve (10). This maintains the set boost pressure for the low pressure return side of the main circuit.

Depending on the direction of swash plate tilt, either port P or S carries high pressure, at the same time closing the respective boost valve (11 or 12). Boost oil can only be fed in on the low pressure side.

If high pressure exceeds the set maximum value of the combined boost and high pressure relief valve, the surplus spills over through the connecting channel to the opposite boost valve and into the low pressure line.

4. Servo control E1P

4.1 Electro-hydraulic Control E1

By means of a suitable controller (see Linde brochure "Controls Program"), the pump flow rate and flow direction are controlled via the energized proportional solenoid.

The "electro-hydraulic servo control E1" uses for its actuation a pilot valve (5) integrated in the servo device (14).

The pilot valve (5) is moved by means of the actuation piston (3), which normally is accurately held in its middle position by two springs. Pilot valve (5) and actuating piston (3) are mechanically linked to each other by a lever (see functional schema E1P). Control of the actuating piston (3) is realized with a control pressure selected at the solenoid (My or Mz), which determines both flow rate and flow direction.

HPV Closed Loop Pump

E₁ Electro-hydraulic Control and PCO

Functional Description

How the control device works:

It is supposed that the proportional solenoids (My and Mz) are not actuated.

If the HPV is driven, there is boost pressure in channel (13). The boost pressure (control pressure) present in the servo E1P will get to channel (13) up to the un-powered proportional valves (16 and 17).

The HPV is in its hydraulic zero position (see description item 2).

If a current induced by the electronics flows in the proportional solenoid (My), this generates a proportional magnetic force (Fm) at the pin of the solenoid. In the subsequent proportional valve (16), a pressure (Fh) is sent to the actuation piston (3), which corresponds to the solenoid signal. The actuation piston (3) shifts accordingly; fluid on the opposite side is discharged to tank via the proportional valve (17); the pilot valve (5) is moved and supplies control pressure to the control piston (6); control piston (7) is relieved to tank; and the pump (swash plate) (2) tilts in the corresponding direction (Precondition: pump pressure below response pressure of the cut-off control device, see description 4.2).

If the signal (Fm) at the solenoid (My) is lessened, the proportional valve (16) reduces the pressure towards actuation piston (3), and the swash angle becomes smaller.

Diagram

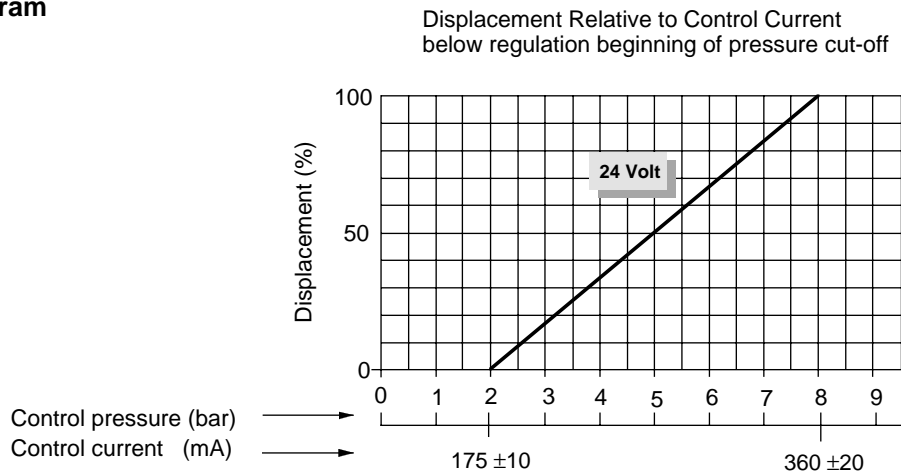

HPV Closed Loop Pump

E₁ Electro-hydraulic Control and PCO

Functional Description

4.2 Pressure cut-off device P

The maximum pressure control device takes pump delivery back on reaching the maximum pressure. While maintaining system pressure, only a small residual flow passes the high pressure relief valves, optimizing energy consumption and thermal balance of the system. Propulsion drives with cut-off device may show a different behavior than without. This has to be kept in mind when conceiving a drive.

Functional sequence

The maximum pressure control (P) is an integral part of the E1P type control (14). The pilot (18=18/1 and 18/2) is internally connected via channels (19 and 20) with the corresponding high pressure channel (P or S).

When reaching a maximum pressure set in the pilot (18/1 or 18/2), the latter connects—as high pressure rises—control pressure (Z or Y) of the control piston (3) to the pre-loading valve (15). For stability reasons, the preloading valve (15) is set at a pressure value slightly higher than the beginning of pump displacement control. Pilot pressure (Z or Y) is reduced by the restrictors (D3 or D4) to a level that the HPV pump will swing back to an angle near zero (irrespective of the displacement preselected by the electric control). Therefore, only a very faint flow of oil determined by the preloading valve (15) spills across the high pressure valve (11 or 12) and overheating of the high pressure circuit is avoided.

Diagram

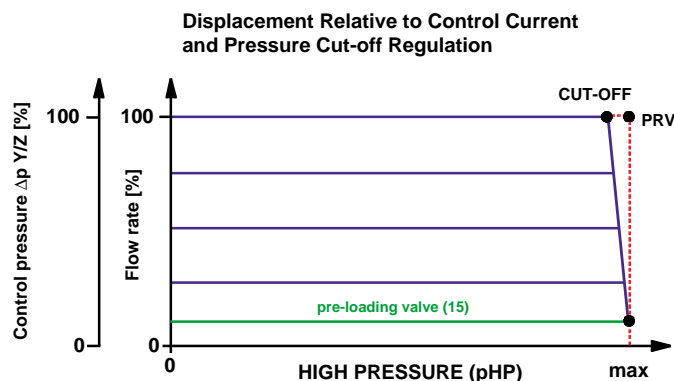

HPV Closed Loop Pump

E₁ Electro-hydraulic Control and PCO

Functional Description

5. Pressure relief valves

5.1 Boost pressure and cold start valve DBE 6 (8 and 10)

The pressure relief valves DBE 6 fitted in the HPV 55 - 02 and its auxiliary pump are factory-set, spring-loaded conical seat ones. They consist of valve body, compression spring and valve poppet, which is forced down on its seat.

The spring force can be varied by means of appropriate springs and shims, in order to adjust the response pressure to the required level of pressure limitation. The complete valve must be fastened with the prescribed locking torque.

The bodies of the two valves are not identical, (see fig.1). They must not be interchanged to avoid malfunction. Sealing is realized by cutting edge on the bottom and by O ring on the top.

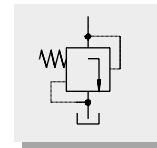
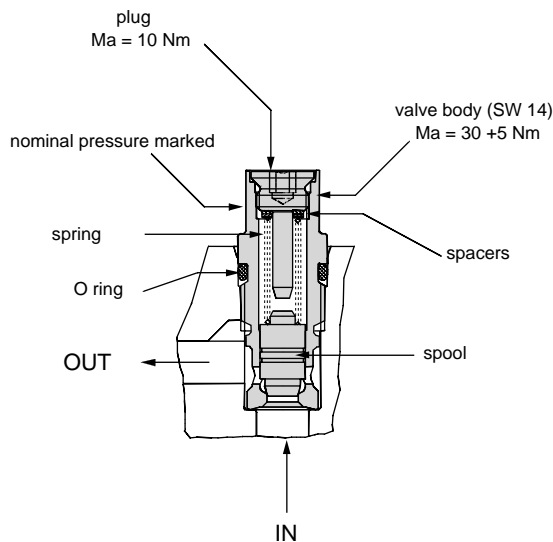
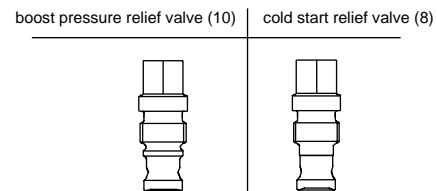

Fig. 1



HPV Closed Loop Pump

E₁ Electro-hydraulic Control and PCO

Functional Description

5.2 Combined pressure relief and make-up valves VD 9 (11) and (12)

The VD9 valve cartridges screwed into the HPV-55 valve plate housing are factory-set, direct acting pressure relief valves with make-up function. They consist of valve body, plug, spring 1, spring 2, snap ring, spring plate and valve spool. The setting is not adjustable. For other pressure settings, the VD9 valve has to be exchanged as a whole.

5.2.1 Function as boost valve (make up)

There is always pressure in the F line (boost pressure). Should pressure in channel P/S be lower than in channel F, pressure in chamber F, due to the differential pressure, acts on the effective area of the check valve poppet, which is thereby shifted against the force of spring 2 and thus connects channel F with P/S. Pressures are balanced off, thus avoiding cavitation.

5.2.2 Function as pressure relief valve

When high pressure in channel P/S, acting on area D of the valve spool, reaches the setting of spring 1, the spool moves against the force of the spring. Connection to channel P/S is established, and pressure can be relieved.

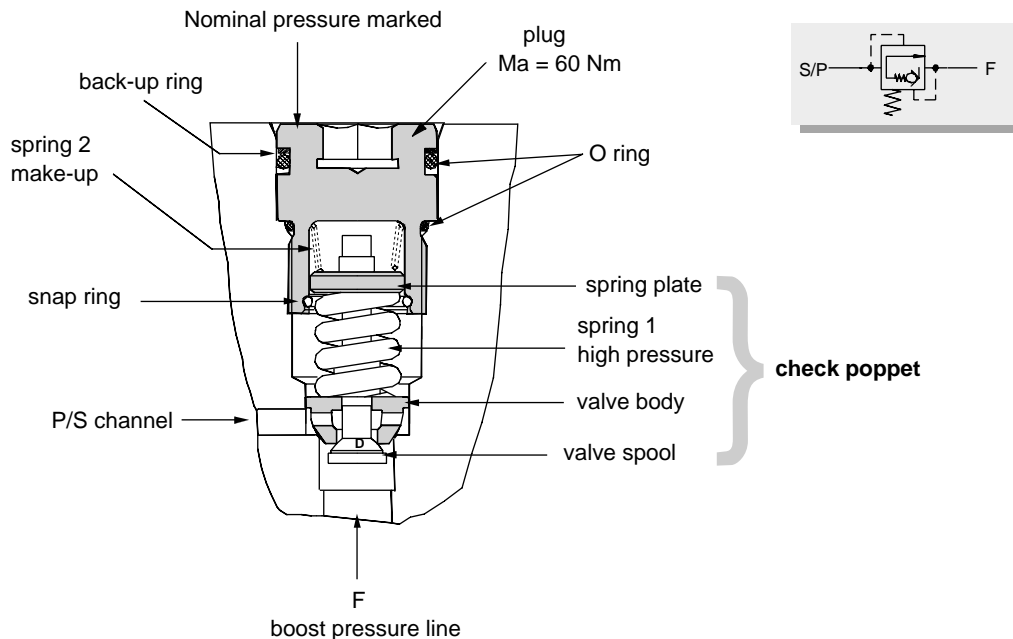

HPV Closed Loop Pump

E₁ Electro-hydraulic Control and PCO

Basic Design of Rotating Group

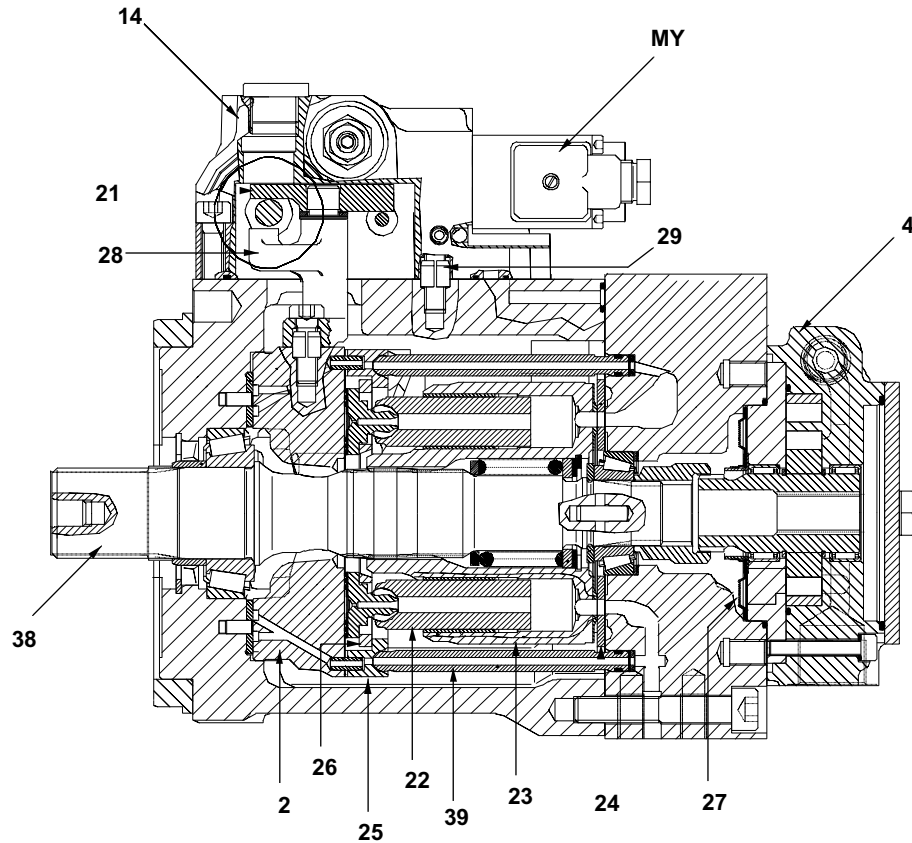

EXPLANATIONS	
2	Swash plate
4	Ancillary pump
14	Electro-hydraulic control E1P
21	Link
22	Working piston
23	Cylinder barrel
24	Port plate
25	Holding clamp
26	Retainer plate
27	Screen
28	Feedback lever
29	Dowel (centering of control E1P)
38	Shaft
39	Tube

HPV Closed Loop Pump E2 Electro-hydraulic Control

Circuit Diagram

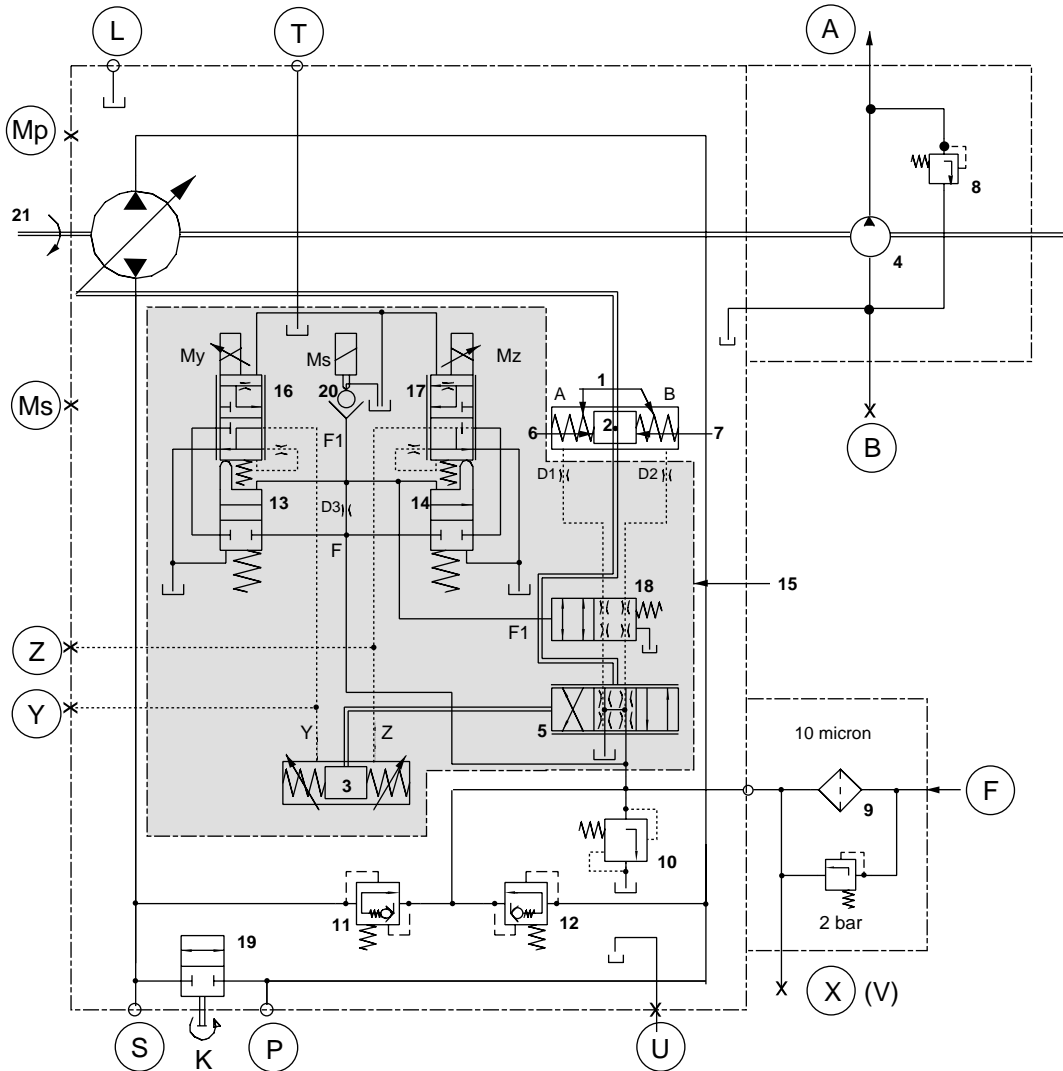

EXPLANATIONS

P, S	High pressure port	X	Boost pressure gauge port
A	Pressure port boost pump	Ms, Mp	High pressure gauge port
B	Suction port boost pump	L1, L2	Vent ports
F	Control and boost pressure supply	L, U	Drain (filling, vent) ports and flushing return from hydr. motor
Y	Control pressure gauge port	Z	Control pressure gauge port
T	Tank port (filling and vent)	K	Short circuit device

solenoid My energized @ displacement piston A @ HP in port P
solenoid Mz energized @ displacement piston B @ HP in port S

HPV Closed Loop Pump E2 Electro-hydraulic Control

Description

Type HPV 55 - 02 variable pumps are axial piston pumps of swash plate design with variable displacement for hydrostatic transmissions (HST) in closed loop applications.

The HPV 55 - 02 pump described in this paper is equipped with an E2 type electro-hydraulic control.

All auxiliary features for closed loop are integrated in or attached to the pump:

- **Servo control E2:** can be mounted on or taken off without interfering with the main pump.
- **Ancillary pump:**
 - inner ring gear pump for one sense of rotation, internal suction; without interfering with the main pump, the ancillary pump can be put on or off.
 - suction side is screen-protected.
 - provides control pressure for the swash plate.
 - leakage from the closed loop is restituted with a defined preload.
- **Cold start valve:** protects the cooler; responds only when back pressure in the cooling or filtration circuit exceeds the set level. Its setting is always higher than that of the boost pressure relief valve.
- **Boost pressure relief valve:** limits the maximum control and boost pressure.
- **Combined high pressure relief and boost check valves:**
 - relief valves limit the maximum working pressure in the high pressure line.
 - boost check valves are for make-up in the closed loop circuit (to replace leakage losses) .
- **Cartridge filter:** 10 micron replacement cartridge filter. The entire flow of the ancillary pump passes through this filter.

HPV Closed Loop Pump

E2 Electro-hydraulic Control

Functional Description

- 1. Mechanical zero position**
- 2. Hydraulic zero position**
- 3. Boost and high pressure circuit**
- 4. Servo control E2**
- 5. Pressure relief valve**
- 6. Ancillary pump**
- 7. Short circuit device “K”**

1. Mechanical zero position

As long as the HPV pump is not driven by the prime mover, it is held in neutral position by mechanical means.

The swash plate (item 2 in the circuit diagram) is positively held in its no-flow position by two springs (1) at the displacement pistons, so that at the moment of starting, the pump runs without displacement.

Precondition: the proportional solenoids (My and Mz) are not energized.

This mechanical setting of the zero position is done during assembly in the factory and cannot be altered from outside.

2. Hydraulic zero position

When the pump is driven, it is held in neutral by hydraulic means.

Precondition: proportional solenoids (My and Mz) are not energized.

Boost pressure reaching the servo control device E2 via channel F acts as a control pressure.

In its central position, pilot valve (5) connects via the 4/2 way valve (18) and the response time throttles (D1 and D2) both displacement pistons (6 and 7) with the control pressure, thus keeping the swash plate in its neutral position. At the same time, the 4/2-way valve add-on restrictors (18) get changed from the “throttled” to the “unthrottled” stage.

The hydraulic tuning of zero position is done at Linde’s test center. It may be changed only in exceptional cases by trained experts. The corresponding service information must be adhered to.

HPV Closed Loop Pump E2 Electro-hydraulic Control

Functional Description

3. Boost and high pressure circuit

In the swash plate's neutral position, there is no axial stroking of the pistons and therefore, no pump delivery.

The pump shaft drives not only the rotating group of the main pump but also the ancillary pump (4). This sucks hydraulic oil from inside the pump housing and sends it on a trip from port A (see circuit diagram) to a cooler (if available) and back into the HPV pump at port F. The cold start valve (8) responds only if back pressure in the cooling and filtration circuit exceeds the set value. The entire flow runs through the 10 micron cartridge filter (9). Back in the pump, the oil passes the two boosting valves (combined valves 11+12), flows on to the two high pressure ports (P+S) and then to the servo control (15).

The excess oil not required to make up for leakage losses bleeds off at the boost pressure relief valve (10). This maintains the set boost pressure for the low pressure return side of the main circuit.

Depending on the direction of swash plate tilt, either port P or S carry high pressure, at the same time closing the respective boost valve (11 or 12). Boost oil can only be fed in on the low pressure side.

If high pressure exceeds the set maximum value of the combined boost and high pressure relief valve, the surplus spills over through the connecting channel to the opposite boost valve and into the low pressure line.

4. Servo control E2

The "electro-hydraulic servo control" uses for its actuation a pilot valve (5) integrated in the servo device (15).

The pilot valve (5) is moved by means of the actuation piston (3), which normally is accurately held in its middle position by two springs. Pilot valve (5) and actuating piston (3) are mechanically linked to each other by a lever (see functional schema E2). Control of the actuating piston (3) is realized with a control pressure selected at the solenoid (My or Mz), which determines both amount and direction of pump flow.

HPV Closed Loop Pump E2 Electro-hydraulic Control

Functional Description

How the control device works:

It is supposed that the proportional solenoids (M_y and M_z) are not actuated and the on/off solenoid (M_s) is energized.

If the HPV is driven, there is boost pressure in channel F. The boost pressure (control pressure) present in the servo E2 travels to the two 2/2-way valves (13) and (14) after passing channel F, restrictor D1 and channel F1. These are being switched in the "through" position, so that a pressure from channel F stands by in front of the un-powered proportional valves (16) and (17). At the same time, the 4/2-way valve (18) is changed from the throttled stage to unthrottled.

The HPV is in its hydraulic zero position (see description item 2).

If a current induced by the electronics flows in the proportional solenoid (M_y), this generates a proportional magnetic force (F_m) at the pin of the solenoid. In the subsequent proportional valve (16) a pressure (F_h) is sent to the actuation piston (3), which corresponds to the solenoid signal. The actuation piston (3) shifts accordingly, fluid on the opposite side is discharged to tank via the proportional valve (17); the pilot valve (5) is moved and supplies control pressure to the control piston (6); control piston (7) is relieved to tank; and the pump (swash plate) (2) tilts in the corresponding direction.

If the signal (F_m) at the solenoid (M_y) is lessened, the proportional valve (16) reduces the pressure towards actuation piston (3) and the swash angle becomes smaller.

Function of the on/off solenoid M_s :

As long as the on/off solenoid (M_s) remains de-energized, its pin stays retracted. The ball (20) lifts up from its seat, thereby allowing pressure in channel F1 behind the restrictor D3 to drop down to tank level.

The 2/2-way valves (13 and 14) are switched back to "closed," whereby pressure supply is taken away from the proportional valves (16 and 17). This causes the proportional valve (16 or 17) controlled by the proportional solenoid (M_y or M_z) to be pushed back mechanically to its rest position. The pressure in front of the actuation piston (3) collapses; the piston is mechanically pushed back to neutral and moves the pilot valve (5) to the middle position. Energizing of solenoid (M_s) makes the pressure in channel F1 drop and the 4/2-way valve (18) switch from "unthrottled" to "throttled."

Result:

- smooth coasting owing to a metered prolongation of the response time of the control pistons (6 and 7) obtained by means of the response restrictors (D1 and D2) and the add-on restrictors (4/2-way valve 18).
- unintentional starting of the machine is avoided with a suitable electronic control. This kind of function can be ascertained by using the Linde CED control unit.

HPV Closed Loop Pump E2 Electro-hydraulic Control

Functional Description

5. Pressure relief valves

5.1 Boost pressure and cold start valve DBE 6 (8 and 10)

The pressure relief valves DBE 6 fitted in the HPV 55 - 02 and its auxiliary pump are factory-set spring-loaded conical seat ones. They consist of valve body, compression spring and valve poppet which is forced down on its seat.

The spring force can be varied by means of appropriate springs and shims in order to adjust the response pressure to the required level of pressure limitation. The complete valve must be fastened with the prescribed locking torque.

The bodies of the two valves are not identical (see fig.1). They must not be exchanged with each other to avoid malfunction. Sealing is realized by cutting edge on the bottom and by O ring on the top.

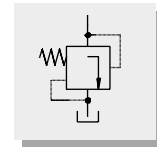
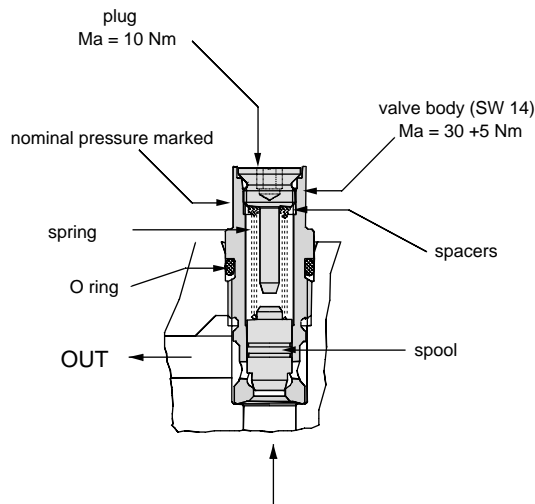
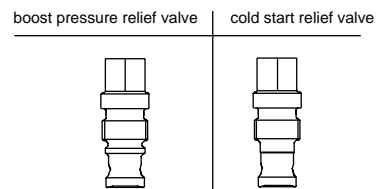

Fig. 1



HPV Closed Loop Pump E2 Electro-hydraulic Control

Functional Description

5.2 Combined pressure relief and make-up valves VD 9 (11 and 12)

The VD9 valve cartridges screwed into the HPV-55 valve plate housing are factory-set direct acting pressure relief valves with make-up function. They consist of valve body, plug, spring 1, spring 2, snap ring, spring plate and valve spool. The setting is not adjustable. For other pressure settings, the VD9 valve has to be exchanged as a whole.

5.2.1 Function as boost valve (make-up)

There is always pressure in the F line (boost pressure). Should pressure in channel P/S be lower than in channel F, pressure in chamber F, due to the differential pressure, acts on the effective area of the check valve poppet, which is thereby shifted against the force of spring 2 and connects channel F with P/S. Pressures are balanced off, thus avoiding cavitation.

5.2.2 Function as pressure relief valve

When high pressure in channel P/S, acting on area D of the valve spool, reaches the setting of spring 1, the spool moves against the force of the spring. Connection to channel P/S is established, and pressure can be relieved.

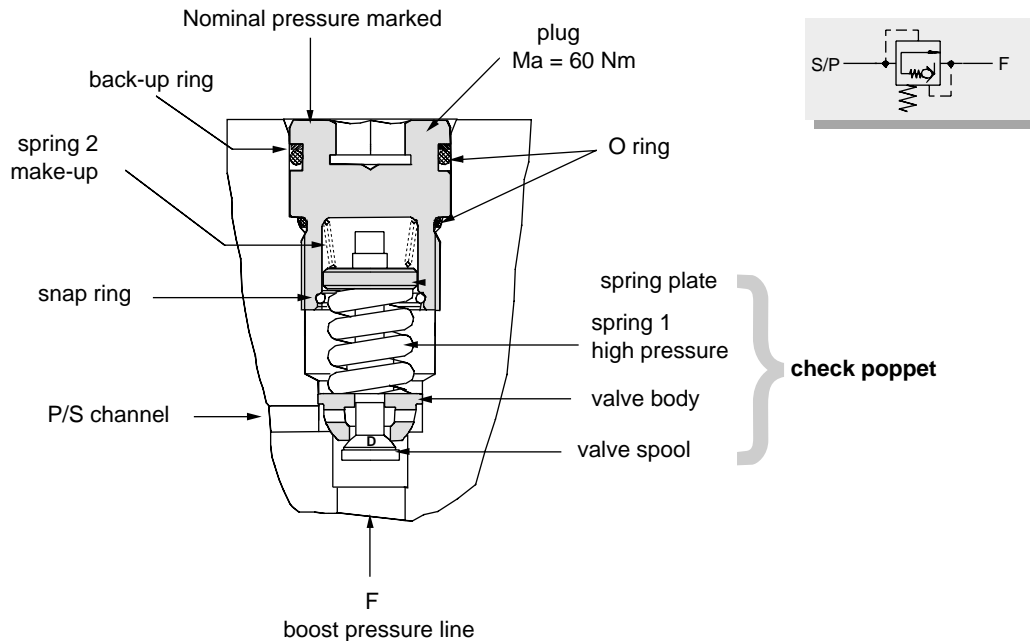

HPV Closed Loop Pump E2 Electro-hydraulic Control

Basic Design of Rotating Group

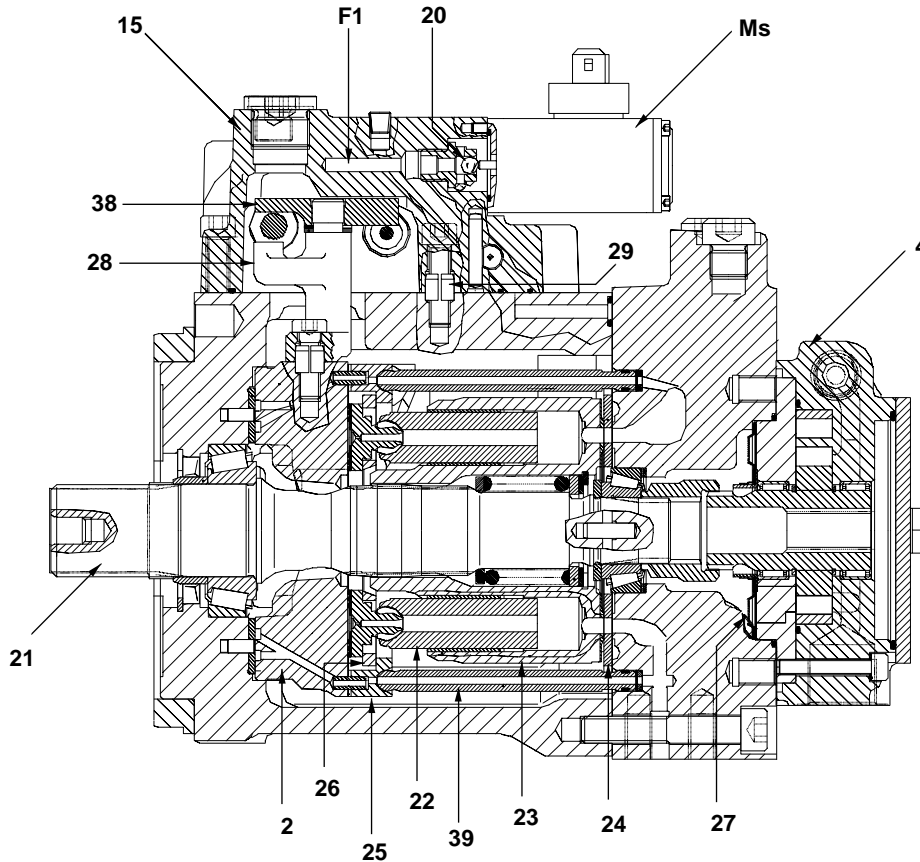

EXPLANATIONS	
2	Swash plate
4	Ancillary pump
15	Electro-hydraulic control E2
21	Shaft
22	Working piston
23	Cylinder barrel
24	Port plate
25	Holding clamp
26	Retainer plate
27	Screen
28	Feed back lever
29	Dowel (fixing of control E2)
38	Link
39	Tube