

ENGINEERING
TOMORROW



Service Manual

Transit Mixer Axial Piston Pump

Size 070/089



Revision history*Table of revisions*

Date	Changed	Rev
July 2017	Updated to Engineering Tomorrow	0203
Mar 2014	Converted to Danfoss layout – DITA CMS	BB
19 Oct, 2012	Major update - The MDC control added	BA
14 Oct, 2011	Images data change	AE
Jul, 2011	Grammar spelling, new images with speed sensor	AD
02 Nov, 2010	No technical change, word spelling	AC
24 Aug, 2010	New Backpage	AB
24 Jun, 2010	First Edition	AA

Contents

Literature reference

TMP literature reference 5

Introduction

Overview.....6
 Warranty.....6
 Symbols used in Danfoss literature.....6
 General instructions.....6
 Safety precautions.....7
 Unintended machine movement.....8
 Flammable cleaning solvents.....8
 Fluid under pressure.....8
 Personal safety.....8
 Hazardous material.....8
 Design.....8
 System circuit.....9
 Basic Closed Circuit.....9
 Case drain and heat exchanger.....9

Operation

High pressure relief valve (HPRV) and charge check valve..... 11
 Charge pressure relief valve (CPRV) 12
 Electrical Displacement Control (EDC)..... 12
 EDC Principle..... 12
 Manual Displacement Control (MDC)..... 13
 MDC principle..... 13
 MDC with control cut off (CCO)..... 13
 Manual Over Ride (MOR)..... 14

Operating Parameters

Overview..... 15
 Input Speed..... 15
 System Pressure..... 15
 Charge Pressure..... 15
 Charge inlet pressure..... 16
 Case Pressure..... 16
 Temperature and Viscosity..... 16
 Temperature..... 16
 Viscosity..... 16
 General specification..... 16
 Physical Properties..... 17
 Operating parameters..... 17
 Fluid Specifications..... 18

Fluid and Filter Maintenance

Fluid and filter recommendations..... 19
 Port Locations and Gauge Installation..... 19

Initial Startup Procedures

General21
 Start-Up procedure.....21

Troubleshooting

Overview..... 22
 Safety Precautions..... 22
 Electrical Troubleshooting (TMP EDC)..... 22
 System Operating Hot..... 22
 Neutral Difficult or Impossible to Find..... 23
 System Will Not Operate in Either Direction..... 23
 System Noise or Vibration..... 24
 Sluggish System Response..... 24
 Transmission Operates Normally in One Direction Only..... 24

Contents**Adjustments**

Pump Adjustment.....	25
Standard Procedures.....	25
Charge Pressure Relief Valve Adjustments.....	25
EDC neutral adjustment.....	26
MDC Control Neutral Adjustment.....	27
Mechanical Neutral Adjustment.....	29
Pump setup.....	31
Servo adjustment.....	31

Minor Repair

Standard Procedures, Removing the Pump.....	32
Disassembly.....	32
Inspection.....	32
Reassembly.....	32
EDC/MDC Control.....	32
Removal.....	32
Inspection.....	32
Reassembly.....	32
EDC Control.....	34
Control Solenoids.....	35
Removal.....	35
Inspection.....	35
Reassembly.....	35
MDC with CCO Control.....	36
Control Solenoids.....	37
Removal.....	37
Inspection.....	37
Reassembly.....	37
Shaft Seal Replacement.....	37
Removal.....	38
Inspection.....	38
Reassembly.....	38
Charge Pump.....	38
Charge Pump Removal (Removable Auxiliary Pad/Cover).....	38
Inspection.....	39
Reassembly.....	39
High Pressure Relief Valves (HPRV).....	40
Removal.....	40
Inspection.....	40
Reassembly.....	40
Charge Pressure Relief Valve.....	41
Removal.....	41
Inspection.....	41
Reassembly.....	41

Torque Chart

Fastener Size and Torques.....	43
Plug Size and Torques.....	43
EDC Fasteners and Plugs.....	43
MDC Fasteners and Plugs.....	45

Literature reference

TMP literature reference

Further available literature

Description	Type	Literature number
TMP Transit Mixer Axial Piston Pump, Size 070/089	Technical Information	L1006391
TMP Transit Mixer Axial Piston Pump, Size 070/089	Service Manual	L1010109
TMP Transit Mixer Axial Piston Pump, EDC/MDC, Size 070/089	Repair Instruction	L1031073
TMP Transit Mixer Axial Piston Pump, NFPE, Size 070/089	Repair Instruction	11029271
TMP EDC Axial Piston Pump, Size 070/089	Datasheet	L1109001
TMP MDC Axial Piston Pump, Size 070/089	Datasheet	L1214176
H1 Electrical Displacement Control (EDC)	Technical Information	11022744
Speed and Temperature Sensor	Technical Information	11046759
Hydraulic Fluids and Lubricants	Technical Information	520L0463
Design Guideline for Hydraulic Fluid Cleanliness	Technical Information	520L0467

Introduction

Overview

This manual includes information on the installation, maintenance, and minor repair of TMP pumps. It includes a description of the unit and its individual components, troubleshooting information, and minor repair procedures.

Performing minor repairs requires the unit to be removed from the vehicle/machine. Thoroughly clean the unit before beginning maintenance or repair activities. Since dirt and contamination are the greatest enemies of any type of hydraulic equipment, follow cleanliness requirements strictly. This is especially important when changing the system filter and when removing hoses or plumbing.

A worldwide network of Danfoss Authorized Service Centers is available for major repairs. Danfoss trains and certifies Authorized Service Centers on a regular basis. You can locate your nearest Authorized Service Center using the distributor locator at www.sauer-danfoss.com.

Warranty

Performing adjustments and minor repairs according to the procedures in this manual will not affect your warranty. Major repairs requiring the removal of a unit's center section, servo sleeves, or front flange voids the warranty unless a Danfoss Authorized Service Center performs them.

Symbols used in Danfoss literature

Service symbols used in Danfoss literature

Symbol description	
	WARNING may result in injury
	CAUTION may result in damage to product or property
	Non-reusable part, use a new part
	External hex head
	Internal hex head
	Lubricate with hydraulic fluid
	Pressure measurement/gauge location or specification
	Clean area or part
	Be careful not to scratch or damage
	Note correct orientation
	Torque specification
	Pull out with tool – press fit
	Cover splines with installation sleeve
	Inspect for wear or damage

The symbols above appear in the illustrations and text of this manual. They are intended to communicate helpful information at the point where it is the most useful to the reader. In most instances, the appearance of the symbol itself denotes its meaning. The legend above defines each symbol and explains its purpose.

General instructions

Follow the general procedures below when repairing TMM constant displacement closed circuit motors:

Remove the unit

Prior to performing major repairs, remove the unit from the vehicle/machine. Chock the wheels on the vehicle or lock the mechanism to inhibit movement. Be aware that hydraulic fluid may be under high pressure and/or hot. Inspect the outside of the pump and fittings for damage. Cap hoses and plug ports after removal to prevent contamination.

Introduction

Keep it clean

 Cleanliness is a primary means of assuring satisfactory motor life on both new and repaired units. Clean the outside of the motor thoroughly before disassembly. Take care to avoid contamination of the system ports. Cleaning parts by using a clean solvent wash and air drying is usually adequate. As with any precision equipment, you must keep all parts free of foreign material and chemicals. Protect all exposed sealing surfaces and open cavities from damage and foreign material. If left unattended, cover the pump with a protective layer of plastic.

Replace all O-rings and gaskets

 We recommend you replace all O-rings and seals during service. Lightly lubricate O-rings with clean petroleum jelly prior to assembly.

Secure the unit

 For repair, place the unit in a stable position with the shaft pointing downward. It will be necessary to secure the motor while removing and torquing fasteners and components.

Safety precautions

Always consider safety precautions before beginning a service procedure. Take the following general precautions whenever servicing a hydraulic system:

Warning

Unintended machine movement

Unintended movement of the machine or mechanism may cause injury to the technician or bystanders. To protect against unintended movement, secure the machine or disable/disconnect the mechanism while servicing.

Warning

Flammable cleaning solvents

Some cleaning solvents are flammable. To avoid possible fire, do not use cleaning solvents in an area where a source of ignition may be present.

Warning

Fluid under pressure

Escaping hydraulic fluid under pressure can have sufficient force to penetrate your skin causing serious injury and/or infection. This fluid may also be hot enough to cause burns. Use caution when dealing with hydraulic fluid under pressure. Relieve pressure in the system before removing hoses, fittings, gauges, or components. Never use your hand or any other body part to check for leaks in a pressurized line. Seek medical attention immediately if you are cut by hydraulic fluid.

Warning

Personal safety

Protect yourself from injury. Use proper safety equipment including safety glasses at all times.

Introduction

 **Warning**

Hazardous material

Hydraulic fluid contains hazardous material. Avoid contact with hydraulic fluid. Always dispose of used hydraulic fluid according to state and federal environmental regulations.

Unintended machine movement

 **Warning**

Unintended machine movement

Unintended movement of the machine or mechanism may cause injury to the technician or bystanders. To protect against unintended movement, secure the machine or disable/disconnect the mechanism while servicing.

Flammable cleaning solvents

 **Warning**

Flammable cleaning solvents

Some cleaning solvents are flammable. To avoid possible fire, do not use cleaning solvents in an area where a source of ignition may be present.

Fluid under pressure

 **Warning**

Fluid under pressure

Escaping hydraulic fluid under pressure can have sufficient force to penetrate your skin causing serious injury and/or infection. This fluid may also be hot enough to cause burns. Use caution when dealing with hydraulic fluid under pressure. Relieve pressure in the system before removing hoses, fittings, gauges, or components. Never use your hand or any other body part to check for leaks in a pressurized line. Seek medical attention immediately if you are cut by hydraulic fluid.

Personal safety

 **Warning**

Personal safety

Protect yourself from injury. Use proper safety equipment including safety glasses at all times.

Hazardous material

 **Warning**

Hazardous material

Hydraulic fluid contains hazardous material. Avoid contact with hydraulic fluid. Always dispose of used hydraulic fluid according to state and federal environmental regulations.

Design

Danfoss TMP closed circuit piston pumps convert input torque into hydraulic power. The input shaft transmits rotational force to the cylinder block. Bearings at the front and rear of the pump support the

Introduction

shaft. Splines connect the shaft to the cylinder block. A lip-seal at the front end of the pump prevents leakage where the shaft exits the pump housing. The spinning cylinder block contains nine reciprocating pistons. Each piston has a brass slipper connected at one end by a ball joint. The block springs, ball guide, and slipper retainer hold the slippers to the swashplate. The reciprocating movement of the pistons occurs as the slippers slide against the inclined swashplate during rotation. Via the valve plate, one half of the cylinder block is connected to low pressure and the other half to high pressure. As each piston cycles in and out of its bore, fluid is replenished by charge flow and displaced to the outlet thereby imparting hydraulic power into the system. A small amount of fluid is allowed to flow from the cylinder block/valve plate and slipper/swashplate interfaces for lubrication and cooling. Case drain ports return this fluid to the reservoir.

The angle of the swashplate controls the volume and direction of fluid displaced into the system. The servo piston controls the angle of the swashplate. The pump control, by varying the pressure at the servo piston, controls the piston's position. An electric signal to the control coils or mechanical signal to the control transmits the command from the operator to the pump. Mechanical feedback of the swashplate position to the control through the feedback pins allows for very precise displacement control and increases overall system stability.

Cross section view of TMP

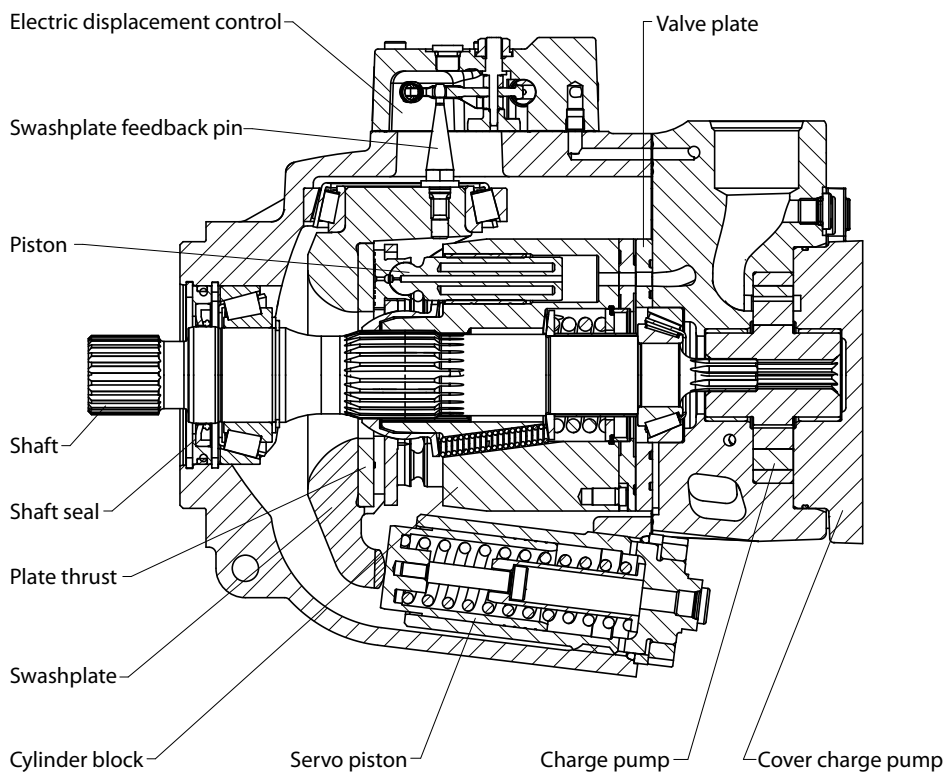

System circuit

Basic Closed Circuit

Hydraulic lines connect the main ports of the pump to the main ports of the motor. Fluid flows in either direction from the pump to the motor and back. Either of the hydraulic lines can be under high pressure. In pumping mode the position of the pump swashplate determines which line is high pressure as well as the direction of fluid flow.

Case drain and heat exchanger

The pump and motor require case drain lines to remove hot fluid from the system. The pump and motor drain from the topmost port to ensure the cases remain full of fluid. The motor case drain can connect to

Introduction

the lower drain port on the pump housing or it can tee into the case drain line upstream of the heat exchanger. A heat exchanger with bypass valve cools the case drain fluid before it returns to the reservoir.

The schematics below show the function of a hydrostatic transmission using an TMP axial variable displacement pump with electric/manual proportional displacement control (EDC/MDC) and an TMM fixed displacement motor with integrated loop flushing device.

System circuit diagram of TMP EDC with TMM

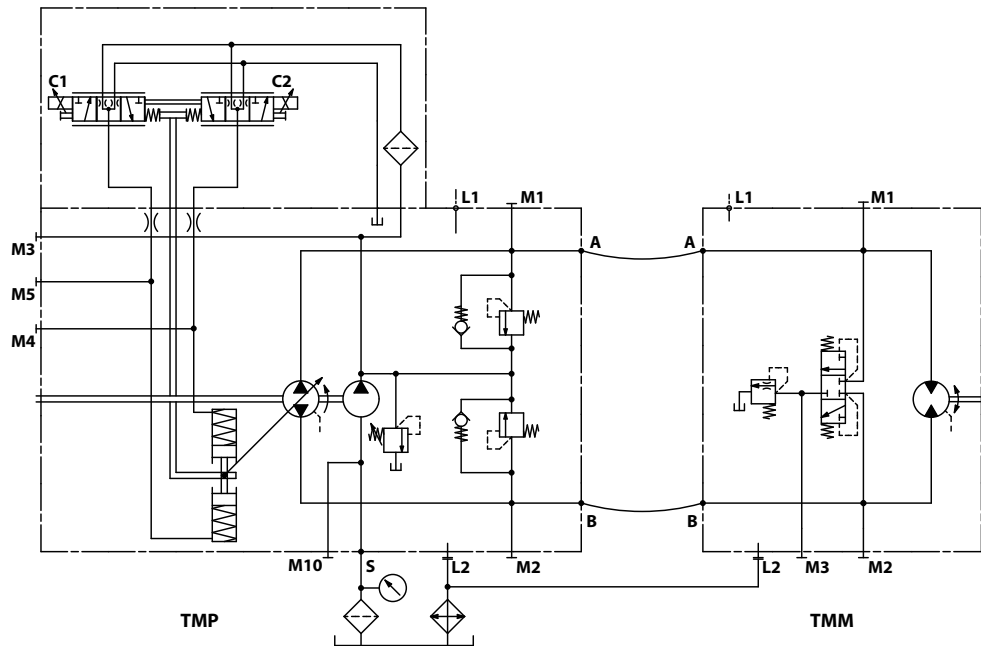

System circuit diagram of TMP MDC with TMM

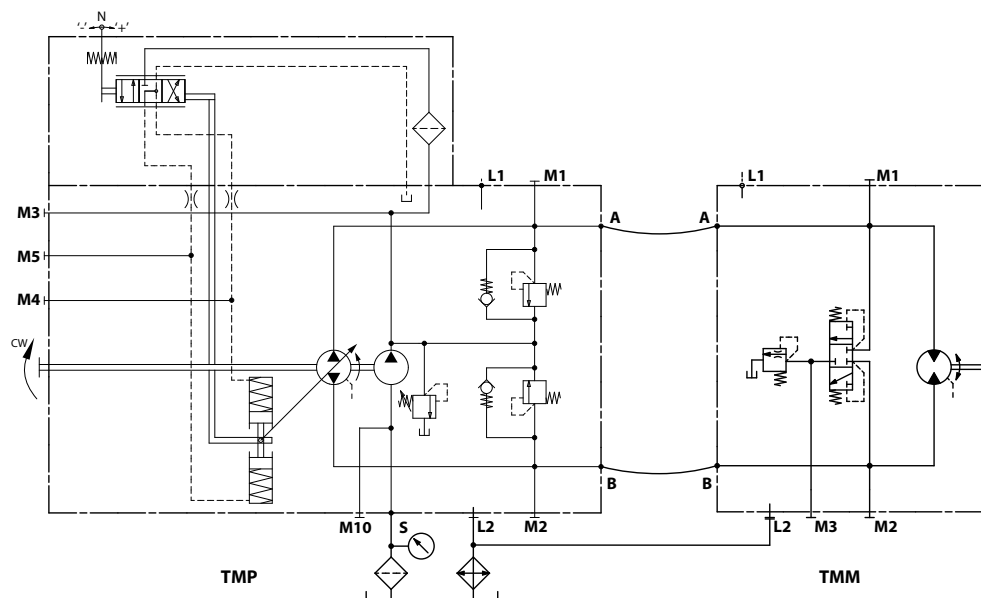

Legend:

- A, B** – System ports: Ø 25.4 mm
- L1, L2** – Case drain ports: M22x1.5
- M1, M2** – System A/B gauge ports: M12x1.5

- M3** – Charge gauge port, after filtering: M12x1.5
- M4, M5** – Servo gauge ports: M12x1.5
- M10** – Charge pump inlet pressure port: M12x1.5
- S** – Charge inlet port: M42x2

Operation

High pressure relief valve (HPRV) and charge check valve

The TMP pumps are equipped with a combination high pressure relief and charge check valve. The high-pressure relief function is a dissipative pressure control valve for the purpose of limiting excessive system pressures. The charge check function acts to replenish the low-pressure side of the working loop with charge oil. Each side of the transmission loop has a dedicated HPRV valve that is non-adjustable with a factory set pressure. When system pressure exceeds the factory setting of the valve, oil is passed from the high pressure system loop, into the charge gallery, and into the low pressure system loop via the charge check.

The pump order code allows for different pressure settings to be used at each system port.

HPRVs are set at low flow condition. Any application or operating condition which leads to elevated HPRV flow will cause a pressure rise with flow above the valve setting. Consult factory for application.

System schematic, single pump

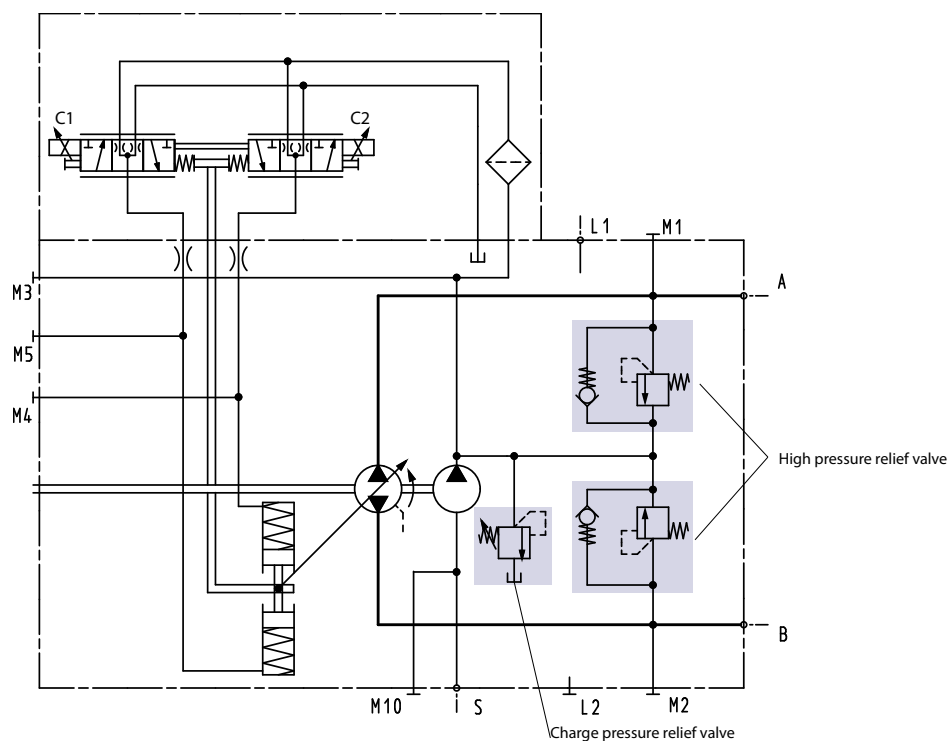

Pressures marked on HPRV valve

Mark	Pressure bar [psi]
28	280 [4061]
42	420 [6092]

HPRV and check valve in charging mode

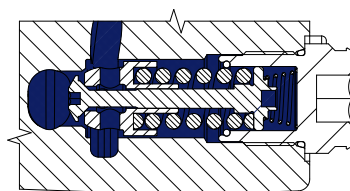

HPRV and check valve in relief mode

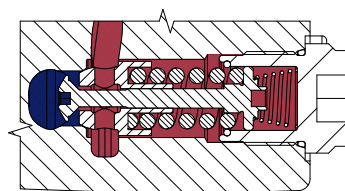

Operation

Charge pressure relief valve (CPRV)

The charge pressure relief valve maintains charge pressure at a designated level above case pressure. The charge pressure relief valve is a direct acting poppet valve which opens and discharges fluid to the pump case when pressure exceeds a designated level. Standard level setting is $\Delta p = 21 \pm 1.1$ bar [304 ± 16 psi] with the pump running at 1500 min^{-1} (rpm) and flow = 23.8 - 29.5 l/min [6.3 - 7.8 US gal/min]. Typical charge pressure increase is 2 bar per 10 l/min [29 psi per 2.64 US gal/min].

Charge pressure relief valve (CPRV)

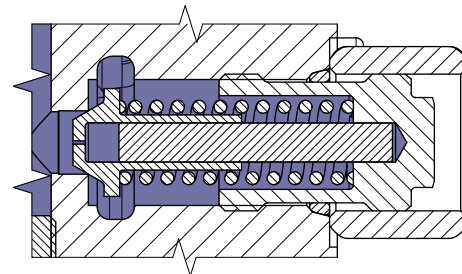

Electrical Displacement Control (EDC)

EDC Principle

The Electrical Displacement Control (EDC) consists of proportional solenoids on each side of a three-position, four-way porting spool. The proportional solenoid applies a force to the spool, which ports hydraulic fluid to either side of the servo piston. Differential pressure across the servo piston rotates the swashplate, changing the pump's displacement from full displacement in one direction to full displacement in the opposite direction.

EDC operation

EDC's are current driven controls requiring a Pulse Width Modulated (PWM) signal. Pulse width modulation allows more precise control of current to the solenoids. The PWM signal causes the solenoid pin to push against the porting spool, which pressurizes one end of the servo piston, while draining the other. Pressure differential across the servo piston moves the swashplate. A swashplate feedback link, opposing control links, and a linear spring provide swashplate position force feedback to the solenoid. The control system reaches equilibrium when the position of the swashplate spring feedback force exactly balances the input command solenoid force from the operator. As hydraulic pressures in the operating loop change with load, the control assembly and servo/swashplate system work constantly to maintain the commanded position of the swashplate.

The EDC incorporates a positive neutral dead-band as a result of the control spool porting, spring preload from the servo piston assembly, and the linear control spring. Once the neutral threshold current is reached, the swashplate position becomes directly proportional to the control current. To minimize the effect of the control neutral deadband, we recommended the transmission controller or operator input device incorporate a jump up current.

The neutral position of the control spool does provide a positive preload pressure to each end of the servo piston assembly.

When the control input signal is either lost or removed, or if there is a loss of charge pressure, the spring-loaded servo piston automatically returns the pump to neutral position.

The EDC is a displacement (flow) control. Pump swashplate position is proportional to the input command and therefore vehicle or load speed (excluding influence of efficiency), is dependent only on the prime mover speed or motor displacement.

Operation

EDC schematic diagram

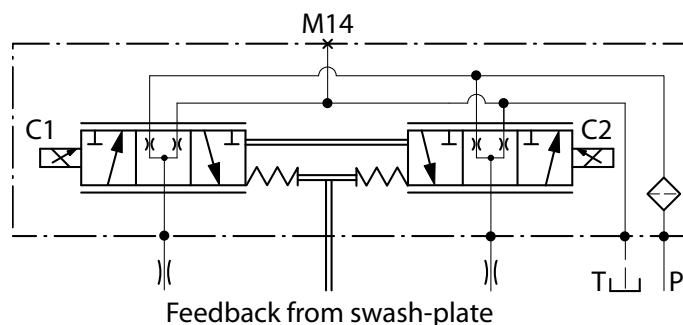

Manual Displacement Control (MDC)

MDC principle

The Manual Displacement Control (MDC) consists of a lever with eccentric shaft centre of a three-position, four-way porting spool. The eccentric shaft applies a force input to the spool, which ports hydraulic pressure to either side of a double acting servo piston.

Differential pressure across the servo piston rotates the swash plate, changing the pump's displacement from full displacement in one direction to full displacement in the opposite direction.

MDC Schematic (P005571E)

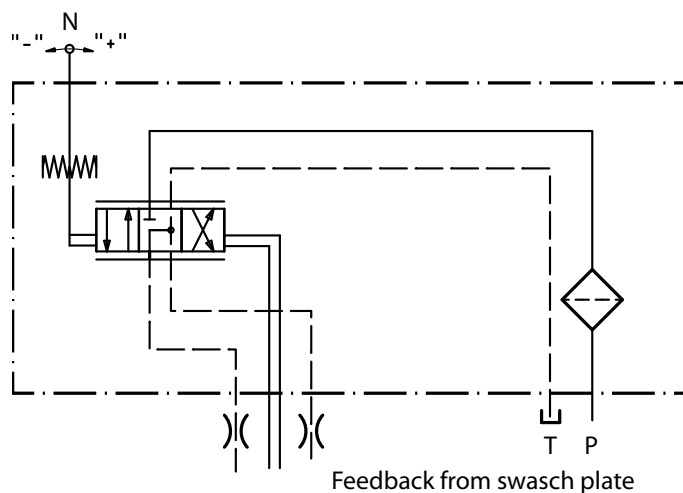

MDC with control cut off (CCO)

If solenoid is loaded by voltage directly from truck battery 24 to 32 V pump work in normal mode if the electric circuit will by switch off pump will go immediately to 0 position.

Operation

Manual Over Ride (MOR)

All controls are available with a Manual Over Ride (MOR) either standard or as an option for temporary actuation of the control to aid in diagnostics. The vehicle or device must always be in a 'safe' condition (i.e. vehicle lifted off the ground) when using the MOR function. The MOR plunger has a 4 mm diameter and must be manually depressed to be engaged. Depressing the plunger mechanically moves the control spool which allows the pump to go on stroke. The MOR should be engaged anticipating a full stroke response from the pump.

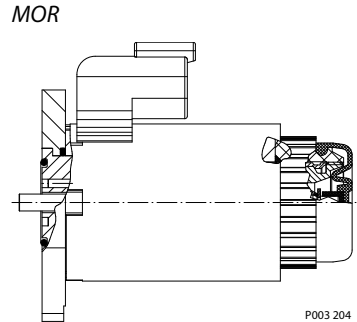

Warning

An O-Ring seal is used to seal the MOR plunger where initial actuation of the function will require a force of 45 N to engage the plunger. Additional actuations typically require a threshold force of 12 N to move the MOR plunger. Force required to keep the pump at full stroke is typically 51 N. Proportional control of the pump using the MOR should not be expected.

Refer to control flow table for the relationship of solenoid to direction of flow.

MOR schematic diagram (EDC shown)

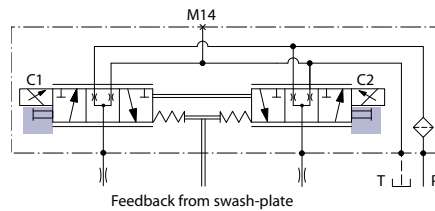

MOR schematic diagram (MDC shown)

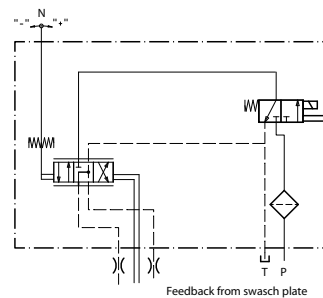

Operating Parameters

Overview

This section defines the operating parameters and limitations for TMP pumps with regard to input speeds and pressures. For actual parameters, refer to the operating parameters for each displacement.

Input Speed

Minimum speed is the lowest input speed recommended during engine idle condition. Operating below minimum speed limits the pump's ability to maintain adequate flow for lubrication and power transmission.

Rated speed is the highest input speed recommended at full power condition. Operating at or below this speed generally yields satisfactory product life.

Maximum speed is the highest operating speed permitted. Exceeding maximum speed reduces product life and can cause loss of hydrostatic power and braking capacity. Never exceed the maximum speed limit under any operating conditions.

When determining speed limits for a particular application see Danfoss publication *Pressure and speed limits*.

Warning

Unintended vehicle or machine movement hazard. Exceeding maximum speed may cause a loss of hydrostatic drive line power and braking capacity. You must provide a braking system, redundant to the hydrostatic transmission, sufficient to stop and hold the vehicle or machine in the event of hydrostatic drive power loss.

System Pressure

System pressure is the differential pressure between system ports A & B. It is the dominant operating variable affecting hydraulic unit life. High system pressure, which results from high load, reduces expected life. Hydraulic unit life depends on speed and normal operating—or weighted average—pressure that you can only determine from a duty cycle analysis.

Applied pressure is the chosen application pressure in the order code for the pump. This is the pressure at which the drive line generates maximum pull or torque in the application.

Rated pressure is the design pressure for the pump. Applications with applied pressures at or below this pressure should yield satisfactory unit life given proper component selection.

Maximum pressure (peak) is the highest intermittent pressure allowed under any circumstances. Applications with applied pressures between rated and maximum require factory approval with complete application, duty cycle, and life expectancy analysis.

[All pressure limits are differential pressures referenced to low loop \(charge\) pressure. Subtract low loop pressure from gauge readings to compute the differential.](#)

Charge Pressure

An internal charge relief valve regulates charge pressure. The internal charge pump supplies the control with pressure to operate the swashplate and to maintain a minimum pressure in the low side of the transmission loop.

Minimum charge pressure is the lowest pressure safe working conditions allow in the system loop. Minimum control pressure requirements are a function of speed, pressure, and swashplate angle, and may be higher than the minimum charge pressure shown in the technical specifications.

Maximum charge pressure is the highest charge pressure the charge relief adjustment allows, and which provides normal component life. You can use elevated charge pressure as a secondary means to reduce the swashplate response time.

Operating Parameters

The charge pressure setting listed in the order code is the set pressure of the charge relief valve with the pump in neutral, operating at 1500 min⁻¹ (rpm), and with a fluid viscosity of 32 mm²/sec [150 SUS]. The charge pressure setting is referenced to case pressure (the differential pressure above case pressure).

Charge inlet pressure

At normal operating temperature charge inlet pressure must not fall below rated charge inlet pressure. **Minimum charge inlet pressure** is only allowed at cold start conditions. In some applications, you may need to warm up the fluid (start the prime mover without using the vehicle/machine functions) before moving the vehicle or operating the machine.

Case Pressure

Do not exceed rated case pressure under normal operating conditions. During cold start, keep case pressure below maximum intermittent case pressure. Size drain plumbing accordingly.

Warning

Possible component damage or leakage. Operation with case pressure in excess of stated limits may damage seals, gaskets, and/or housings, causing external leakage. This condition may also affect performance since charge and system pressure are referenced to case pressure.

Temperature and Viscosity

Temperature

High temperature limits apply at the hottest point in the transmission loop, which is normally the motor case drain. Ensure the system generally runs at or below the rated temperature.

The **maximum intermittent temperature** is based on material properties. Never exceed it!

Cold oil will generally not affect the durability of the transmission components, but it may affect the ability of oil to flow and transmit power: therefore ensure temperatures remain 16 °C [30 °F] above the pour point of the hydraulic fluid. **Minimum temperature** relates to the physical properties of component materials. Size heat exchangers to keep the fluid within these limits. Danfoss recommends testing to verify that these temperature limits are not exceeded.

Viscosity

For maximum efficiency and bearing life, ensure the fluid viscosity remains in the recommended range.

Minimum viscosity should be encountered only during brief occasions of maximum ambient temperature and severe duty cycle operation.

Maximum viscosity should be encountered only at cold start.

General specification

General specifications

Design	Axial piston pump cradle swashplate design with variable displacement
Direction of rotation	Clockwise, counterclockwise

Operating Parameters

General specifications (continued)

Pipe connections	Main pressure ports: ISO split flange boss Remaining ports: ISO straight thread O-ring boss
Recommended installation position	Pump installation position is discretionary; however the recommended control position is on the top. The housing must always be filled with hydraulic fluid. Pump shaft connection is discretionary, however it is strongly recommended to use rubber coupling if pump is driven via "cardan" shaft. Correct installation has a significant influence on a life time of the pump.

Caution

The front shaft seal must not be exposed to oil pressure from outside of the unit.
 Boundary position of the MDC lever must be fixed by hard stop on the customer actuation mechanism in order to prevent any damages of MDC.

Physical Properties

Technical data

Features	Unit	Size	
		070	089
Displacement maximum	cm ³ [in ³]	68.3 [4.17]	89.0 [5.43]
Oil volume	l [US gal]	2 [0.53]	2 [0.53]
Mounting flange	SAE ISO 3019/1 flange 127-4 (SAE C), M12x1,75		
Input shaft	Spline shaft SAE, 21 teeth, pitch = 16/32 Spline shaft SAE, 23 teeth, pitch = 16/32 Coupling for Cardan, 23 teeth (only with spline shaft SAE, 23 teeth, pitch = 16/32)		
Auxiliary mounting flange with metric fasteners, shaft splines	SAE A, 11 teeth, pitch = 16/32 SAE B, 13 teeth, pitch = 16/32 SAE B-B, 15 teeth, pitch = 16/32		
Suction port	ISO 6149-1 – M42x2 (O-ring boss)		
Main port configuration	Twin ports SAE J518b Size 1, with metric screws M12		
Case drain ports L1, L2	ISO 6149-1 – M22x1,5 (O-ring boss)		
Other ports	ISO 6149-1 straight thread O-ring boss. See Port Locations and Gauge Installation on page 19.		

Operating parameters

Operating parameters, size 070 / 089

Features		Unit	Sizes 070 / 089
Input speed	Minimum	min ⁻¹ (rpm)	500
	Rated		2500
	Maximum		2900
System pressure	Max. working pressure	bar [psi]	420 [6090]
	Maximum pressure		450 [6525]
	Minimum pressure		10 [145]

Operating Parameters

Operating parameters, size 070 / 089 (continued)

Features		Unit	Sizes 070 / 089
Charge pressure	Minimum	bar [psi]	17 [247]
	Maximum		30 [436]
Control pressure	Minimum (at corner power for EDC)	bar [psi]	21 [305]
	Maximum		30 [435]
Charge pump inlet pressure	Rated	bar (absolute) [in Hg vacuum]	0.7 [9]
	Minimum (cold start)		0.2 [24]
	Maximum		4 [58]
Case pressure	Rated	bar [psi]	3 [44]
	Maximum		5 [73]
Lip seal external pressure	Maximum	bar [psi]	0.4 [5.8]

Fluid Specifications

Fluid specifications

Features		Unit	Sizes 070 / 089
Viscosity	Intermittent ¹	mm ² /s [SUS]	5 [42]
	Minimum		7 [49]
	Recommended range		12-80 [66-370]
	Maximum		1600 [7500]
Temperature range ²	Minimum (cold start) ³	°C [°F]	-40 [-40]
	Recommended range		60-85 [140-185]
	Rated		104 [220]
	Maximum intermittent ¹		115 [240]
Filtration (recommended minimum)	Cleanliness per ISO 4406		22/18/13
	Efficiency (charge pressure filtration)	β-ratio	β ₁₅₋₂₀ = 75 (β ₁₀ ≥ 10)
	Efficiency (suction and return line filtration)		β ₃₅₋₄₅ = 75 (β ₁₀ ≥ 2)
	Recommended inlet screen mesh size	μm	100 – 125

¹ Intermittent = Short term t < 1 min per incident and not exceeding 2 % of duty cycle based load-life
² At the hottest point, normally case drain port
³ Cold start = Short term t < 3 min, p ≤ 50 bar [725 psi], n ≤ 1000 min⁻¹(rpm)

Ratings and data are based on operation with premium petroleum-based hydraulic fluids containing oxidation, rust, and foam inhibitors.

Fluid and Filter Maintenance

Fluid and filter recommendations

To ensure optimum life, perform regular maintenance of the fluid and filter. Contaminated fluid is the main cause of unit failure. Take care to maintain fluid cleanliness when servicing.

Check the reservoir daily for proper fluid level, the presence of water, and rancid fluid odor. Fluid contaminated by water may appear cloudy or milky or free water may settle in the bottom of the reservoir. Rancid odor indicates the fluid has been exposed to excessive heat. Change the fluid and correct the problem immediately if these conditions occur.

Inspect vehicle for leaks daily. Change the fluid and filter per the vehicle/machine manufacturer's recommendations or at intervals shown in the table. We recommend first fluid change at 500 hours.

Fluid and Filter Change Interval

Reservoir type	Max oil change interval
Sealed	2000 hours
Breather	500 hours

High temperatures and pressures will result in accelerated fluid aging. More frequent fluid changes may be required.

Change the fluid more frequently if it becomes contaminated with foreign matter (dirt, water, grease, etc.) or if the fluid is subjected to temperature levels greater than the recommended maximum. Dispose of used hydraulic fluid properly. Never reuse hydraulic fluid.

Change filters with the fluid or when the filter indicator shows it's necessary. Replace all fluid lost during filter change.

For detailed filtration information, see Danfoss publication **520L0463** *Fluids and Filtration*. For information on biodegradable fluids see Danfoss publication **520L0465** *Biodegradable Hydraulic Fluids*.

Warning

Hydraulic fluid contains hazardous material. Avoid contact with hydraulic fluid. Always dispose of used hydraulic fluid according to state and federal environmental regulations.

Port Locations and Gauge Installation

The following table and drawings show the port locations and gauge sizes needed. When testing system pressures, calibrate pressure gauges frequently to ensure accuracy. Use snubbers to protect gauges.

Port Information

Identifier	Port Description	Size	Wrench size	Gauge size, bar [psi]
L1, L2	Case drain ports	M22x1.5	10 mm internal hex	10 [100]
M1, M2, M4, M5	System A/B, charge and servo gage	M12x1.5	6 mm internal hex	50 [1000]
M10	Charge pump inlet pressure	M12x1.5	6 mm internal hex	50 [1000]
S	Charge inlet port	M42x2.0		10 [100]

Fluid and Filter Maintenance

Port locations

P005443E

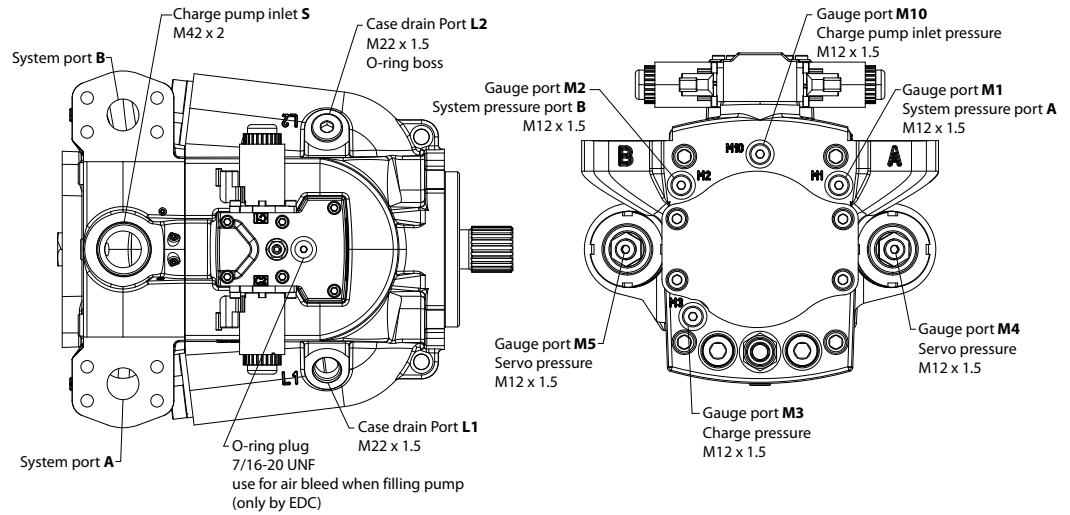

Initial Startup Procedures

General

Follow this procedure when starting-up a new pump installation or when restarting an installation in which the pump has been removed and re-installed on a machine. Ensure pump has been thoroughly tested on a test stand before installing on a machine. Prior to installing the pump, inspect for damage that may have occurred during shipping.

Warning

Unintended movement of the machine or mechanism may cause injury to the technician or bystanders. To protect against unintended movement, secure the machine or disable/disconnect the mechanism while servicing.

Start-Up procedure

1. Ensure that the machine hydraulic oil and system components (reservoir, hoses, valves, fittings, and heat exchanger) are clean and free of any foreign material.
2. Install new system filter element(s) if necessary. Check that inlet line fittings are properly tightened and there are no air leaks.
3. Install the pump. Install a 50 bar [1000 psi] gauge in the charge pressure gauge port M
4. Fill the housing by adding filtered oil in the upper case drain port. If the control is installed on top, open the construction plug in the top of the control to assist in air bleed.
5. Fill the reservoir with hydraulic fluid of the recommended type and viscosity. Use a 10-micron filler filter. Fill inlet line from reservoir to pump.
6. Disconnect the pump from all control input signals.
7. Close construction plug removed in Step 4.

Caution

After start-up the fluid level in the reservoir may drop due to system components filling. Damage to hydraulic components may occur if the fluid supply runs out. Ensure reservoir remains full of fluid during start-up.

Air entrapment in oil under high pressure may damage hydraulic components. Check carefully for inlet line leaks.

Do not run at maximum pressure until system is free of air and fluid has been thoroughly filtered.

8. Use a common method to disable the engine to prevent it from starting. Crank the starter for several seconds. Do not to exceed the engine manufacturer's recommendation. Wait 30 seconds and then crank the engine a second time as stated above. This operation helps remove air from the system lines. Refill the reservoir to recommended full oil level.
9. When the gauge begins to register charge pressure, enable and start engine. Let the engine run for a minimum of 30 seconds at low idle to allow the air to work itself out of the system. Check for leaks at all line connections and listen for cavitation. Check for proper fluid level in reservoir.
10. When adequate charge pressure is established (as shown in model code), increase engine speed to normal operating rpm to further purge residual air from the system.
11. Shut off engine. Connect pump control signal. Start engine, checking to be certain pump remains in neutral. Run engine at normal operating speed and carefully check for forward and reverse control operation.
12. Continue to cycle between forward and reverse for at least five minutes to bleed all air and flush system contaminants out of loop.

Normal charge pressure fluctuation may occur during forward and reverse operation.

13. Check that the reservoir is full. Remove charge pressure gauge.

The pump is now ready for operation.

Troubleshooting

Overview

This section provides general steps to follow if you observe undesirable system conditions. Follow the steps listed until you solve the problem. Some of the items are system specific. We reference the section in this manual if more information is available. Always observe the safety precautions listed in [Safety Precautions](#) and precautions related to your specific equipment.

Safety Precautions

⚠ Caution

High inlet vacuum causes cavitation which can damage internal pump components.

⚠ Warning

Escaping hydraulic fluid under pressure can have sufficient force to penetrate your skin causing serious injury and/or infection. Relieve pressure in the system before removing hoses, fittings, gauges, or components.

⚠ Warning

Unintended movement of the machine or mechanism may cause injury to the technician or bystanders. To protect against unintended movement, secure the machine or disable/disconnect the mechanism while servicing.

⚠ Caution

Contamination can damage internal components and void the manufacturer's warranty. Take precautions to ensure system cleanliness when removing and reinstalling system lines

⚠ Warning

Hydraulic fluid contains hazardous material. Avoid contact with hydraulic fluid. Always dispose of used hydraulic fluid according to state, and federal environmental regulations.

Electrical Troubleshooting (TMP EDC)

Item	Description	Action
Control operates pump in one direction only.	Control coil failure	Measure resistance at coil pins. Resistance should be 14.20 ohms (24V) or 3.66 ohms (12V) at 20°C [70°F]. Replace coil
No pump function	No power to controller	Restore power to controller.
Erratic pump function	Electrical connection to pump is bad.	Disconnect connection, check wires, reconnect wires.

[If available, use manual override to check proper pump operation and verify electrical problem.](#)

System Operating Hot

Item	Description	Action
Oil level in reservoir.	Insufficient hydraulic fluid will not meet cooling demands of system.	Fill reservoir to proper level.
Heat exchanger.	Heat exchanger is not sufficiently cooling the system.	Check air flow and input air temperature for heat exchanger. Clean, repair or replace heat exchanger.

Troubleshooting

Item	Description	Action
Charge pressure.	Low charge pressure will overwork system.	Measure charge pressure. Inspect and adjust or replace charge relief valve. Inspect charge pump. Repair or replace charge pump.
Charge pump inlet vacuum.	High inlet vacuum will overwork system. A dirty filter will increase the inlet vacuum. Inadequate line size will restrict flow.	Check charge inlet vacuum. If high, inspect inlet filter and replace as necessary. Check for adequate line size, length or other restrictions.
System relief pressure settings	If the system relief valves are worn, contaminated, or valve settings are too low, the relief valves will be overworked.	Verify settings of high pressure relief valves and replace valves as necessary.
System pressure.	Frequent or long term operation over system relief setting will create heat in system.	Measure system pressure. If pressure is too high, reduce loads.

Neutral Difficult or Impossible to Find

Item	Description	Action
Input to pump control	Input to control module is operating improperly.	Disconnect input and check to see if pump comes back to neutral. If Yes, input fault, replace/repair external controller. If No, go to next step.
Neutral	Neutral set improperly	Shunt servo gauge ports (M4 and M5) together with external hose and see if pump comes back to neutral. If Yes: Control neutral improperly set (see page 31-34) If neutral still impossible to set, balance swashplate (see Mechanical neutral adjustment, page 35-37). If you still cannot set neutral, replace control.

System Will Not Operate in Either Direction

Item	Description	Action
Oil level in reservoir.	Insufficient hydraulic fluid to supply system loop.	Fill reservoir to proper level.
Pump control orifices	Control orifices are blocked.	Clean control orifices.
Pump control screens	Control screens are blocked.	Replace control screens. Only a Danfoss Authorized Service Center may remove the unit's endcap without voiding the warranty.
Low charge pressure with pump in neutral	Low charge pressure insufficient to recharge system loop.	Measure charge pressure with the pump in neutral. If pressure is low, go to Pump charge relief valve.
Low charge pressure with pump in stroke	Low charge pressure resulting from elevated loop leakage. Insufficient control pressure to hold pump in stroke.	Deadhead the pump to isolate it from the motor. With pump in partial stroke and engaged for only a few seconds, check pump charge pressure. Low charge pressure indicates a malfunctioning pump. Continue to next step. Good charge pressure indicates a malfunctioning motor or other system component. Check motor charge relief operation (if present).
Pump charge relief valve	A pump charge relief valve that is leaky, contaminated, or set too low will depressurize the system.	Adjust or replace pump charge relief valve as necessary.
Charge pump inlet filter	A clogged filter will under supply system loop.	Inspect filter and replace if necessary.
Charge pump	A malfunctioning charge pump will provide insufficient charge flow.	Repair or replace the charge pump.
System pressure	Low system pressure does not provide enough power to move load.	Measure system pressure. Continue to next step.
High pressure relief valve	Defective high pressure relief valve cause system pressure to be low.	Repair or replace high pressure relief valve.
Input to control	Input operating improperly	Repair/replace control.

Troubleshooting

System Noise or Vibration

Item	Description	Action
Reservoir oil level	Low oil level leads to cavitation.	Fill reservoir.
Aeration of the oil/pump inlet vacuum	Air in system decreases efficiency of units and controls. Excessive noise, foaming oil, and hot oil all indicate air in system.	Find location where air is entering into the system and repair. Check that inlet line is not restricted and is proper size.
Cold oil	If oil is cold, it may be too viscous for proper function causing pump cavitation.	Allow the oil to warm up to its normal operating temperature with engine at idle speed.
Pump inlet vacuum	High inlet vacuum causes noise/cavitation.	Check that inlet line is not restricted and is of proper size. Check filter and bypass switch.
Shaft couplings	A loose shaft coupling will cause excessive noise.	Replace loose shaft coupling..
Shaft alignment	Misaligned shafts create noise.	Align shafts.
Charge/system relief valves	Unusual noise may indicate sticking valves and possible contamination.	Clean/replace valves and test pump.

Sluggish System Response

Item	Description	Action
Oil level in reservoir	Low oil level causes sluggish response.	Fill reservoir.
High pressure relief valves settings	Incorrect pressure settings affects system reaction time.	Adjust or replace high pressure relief valves.
Low prime mover speed	Low engine speed reduces system performance.	Adjust engine speed.
Charge pressure	Incorrect pressure affects system performance.	Measure and adjust charge pressure relief or replace charge pump.
Air in system	Air in system produces sluggish system response.	Fill tank to proper level. Cycle system slowly for several minutes to remove air from system.
Contaminated control orifices	Control orifices are plugged.	Clean control orifices.
Contaminated control screens	Supply screen is plugged.	Replace control screens.
Pump inlet vacuum	Inlet vacuum is too high resulting in reduced system pressure.	Measure charge inlet vacuum. Inspect line for proper sizing. Replace filter. Confirm proper bypass operation.

Transmission Operates Normally in One Direction Only

Item	Description	Action
Input to pump control.	Input to control module is operating improperly.	Check control input and repair or replace as necessary.
Control orifices	Control orifice(s) are blocked.	Clean control orifices.
Control screens	Control screen(s) are blocked.	Replace control screens.
Exchange high pressure relief valves	Exchanging the high pressure relief valves will show if the problem is related to the valve function.	If the problem changes direction, replace the valve that does not operate correctly.
Servo pressure low or decaying	Damaged servo seals may prevent servo piston from stroking the pump.	Check for torn/missing servo seals. Replace and retest. Only a Danfoss Authorized Service Center may remove the servo piston without voiding the warranty.

Adjustments

Pump Adjustment

This section offers instruction on inspection and adjustment of pump components. Read through the entire topic before beginning a service activity. Refer to [Port Locations and Gauge Installation](#) on page 19, for location of gauge ports and suggested gauge size.

Standard Procedures

! Caution

Contamination can damage internal components and void your warranty. Take precautions to ensure system cleanliness when removing and reinstalling system lines.

1. With the prime mover off, thoroughly clean the outside of the pump.
2. If removing the pump, tag each hydraulic line. When you disconnect hydraulic lines, cap them and plug each open port to prevent contamination.
3. Ensure the surrounding area is clean and free of contaminants like dirt and grime.
4. Inspect the system for contamination.
5. Check the hydraulic fluid for signs of contamination: oil discoloration, foam in the oil, sludge, or metal particles.
6. If there are signs of contamination in the hydraulic fluid, replace all filters and drain the hydraulic system. Flush the lines and refill the reservoir with the correct filtered hydraulic fluid.
7. Before re-installing the pump, test for leaks.

Charge Pressure Relief Valve Adjustments

This procedure explains how to check and adjust the charge pressure relief valve.

Charge Pressure Adjustment (P005619E)

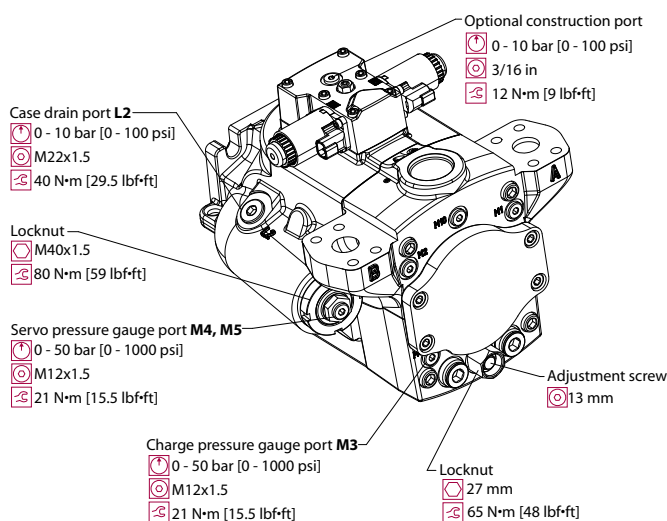

Listed pressures assume a pump speed of 1500 min⁻¹ (rpm). At higher pump speeds (with higher charge flows) the charge pressure will rise over the rated setting.

Adjustments

1. Install a 50 bar [1000 psi] pressure gauge in charge pressure gauge port M3. Install a 10 bar [100 psi] gauge at case drain port L1 or L2. Operate the system with the pump in neutral (zero displacement) when measuring charge pressure.
2. Nominal charge relief valve settings 20.3 - 25 bar [294 - 326 psi] (refer to model code located on serial number plate). This pressure assumes 1500 min⁻¹ (rpm) pump speed and a reservoir temperature of 50°C [120°F], and is referenced to case pressure.
3. Loosen the locknut and turn the adjusting screw clockwise to increase the setting; counterclockwise to decrease it. Approximate adjustment per turn is 2.4 bar.
4. While holding the adjusting screw, torque locknut to 65 N·m [48 lbf·ft].

EDC neutral adjustment

All functions of the Electric Displacement Control (EDC), are preset at the factory. If necessary, adjust the pump to neutral with the pump running on a test stand or on the vehicle/machine with the prime mover operating. If adjustment fails to give satisfactory results, you may need to replace the control or coils. See [Removal](#) on page 35 for details.

Warning

Unintended movement of the machine or mechanism may cause injury to the technician or bystanders. To protect against unintended movement, secure the machine or disable/disconnect the mechanism while servicing.

Adjustment of the EDC is very sensitive. Be sure to hold the hex wrench steady while loosening the locknut. Total adjustment is less than 120 degrees.

EDC Control Adjustment (P005437E)

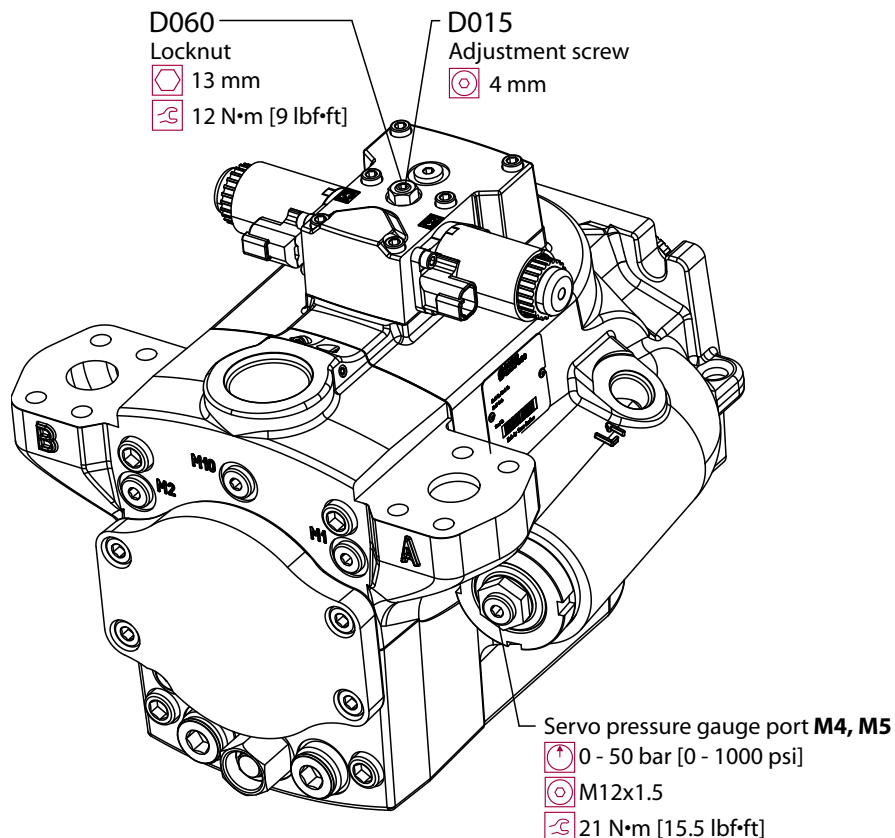

Adjustments

1. Install a 50 bar [1000 psi] gauge in each of the two servo gauge ports (M4 and M5). Disconnect the external control input (electrical connections) from the control. Start the prime mover and operate at normal speed.
2. Use a 4 mm internal hex wrench to hold the neutral adjusting screw (D015) stationary while loosening the locknut (D060) with a 13 mm wrench.
3. Observe pressure gauges. If necessary, turn adjusting screw (D015) to reduce pressure differential.
4. Rotate the neutral adjusting screw (D015) clockwise until the pressure increases on the gauge. Note the angular position of the wrench. Then rotate the neutral adjusting screw counterclockwise until the pressure increases by an equal amount on the other gauge. Again note the angular position of the wrench.
5. Rotate the neutral adjusting screw clockwise half the distance between the wrench positions noted above. The gauges should read the same pressure, indicating that the control is in its neutral position.
6. Hold the neutral adjusting screw stationary and tighten the locknut (D060). Torque to 10 N·m [7.5 lbf·ft]. Do not over torque the nut.
7. When the neutral position is set, stop the prime mover, remove the gauges, and install the gauge port plugs. Reconnect the external control input.

Neutral adjustment (EDC, bottom view)

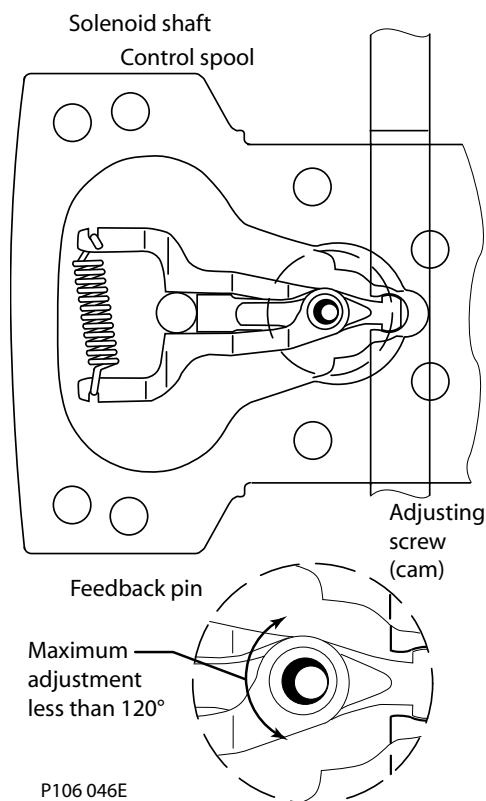

Illustration shows how cam on adjusting pin rotates to adjust for neutral position after pump is re-installed.

A small pressure differential of 1.5 bar [22 psi] or less is acceptable. Zero differential is usually not possible.

MDC Control Neutral Adjustment

All functions of the Mechanical Displacement Control (MDC), are preset at the factory. If necessary, adjust the pump to neutral with the pump running on a test stand or on the vehicle/machine with the prime mover operating. If adjustment fails to give satisfactory results, you may need to replace the control. See [Removal](#) on page 37 for details.

Adjustments

Warning

Unintended movement of the machine or mechanism may cause injury to the technician or bystanders. To protect against unintended movement, secure the machine or disable/disconnect the mechanism while servicing.

Adjustment of the MDC is very sensitive. Be sure to hold the hex wrench steady while loosening the locknut. Total adjustment is ± 3 screw thread.

MDC Control Adjustment (P005612E)

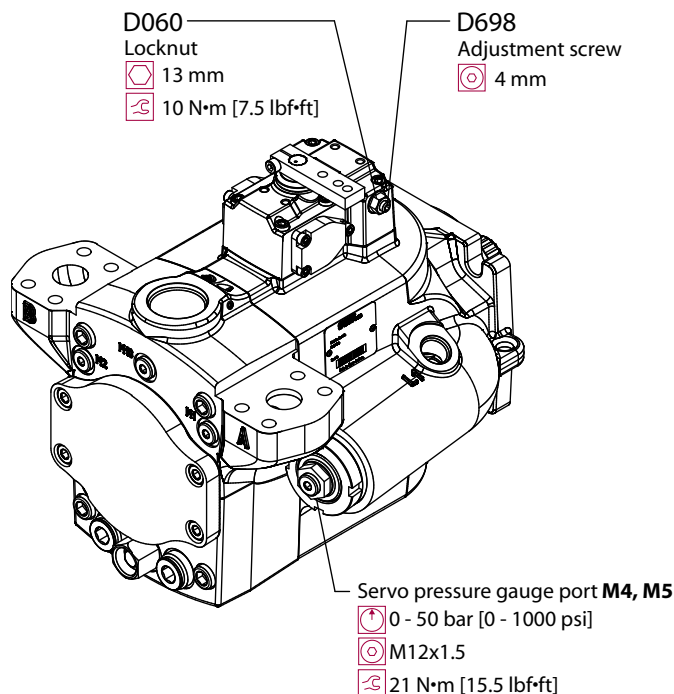

1. Install a 50 bar [1000 psi] gauge in each of the two servo gauge ports (M4 and M5). Disconnect the external control input (mechanical connections) from the control. Start the prime mover and operate at normal speed.
2. Use a 4mm internal hex wrench to hold the neutral adjusting screw (D698) stationary while loosening the locknut (D060) with a 13 mm wrench.
3. Observe pressure gauges. If necessary, turn adjusting screw (D698) to reduce pressure differential.
4. Rotate the neutral adjusting screw (D015) clockwise until the pressure increases on the gauge. Note the angular position of the wrench. Then rotate the neutral adjusting screw counterclockwise until the pressure increases by an equal amount on the other gauge. Again note the angular position of the wrench.
5. Rotate the neutral adjusting screw clockwise half the distance between the wrench positions noted above. The gauges should read the same pressure, indicating that the control is in its neutral position.
6. Hold the neutral adjusting screw stationary and tighten the locknut (D060). Torque to 10 N·m [7.5 lbf·ft]. Do not over torque the nut.

Adjustments

- When the neutral position is set, stop the prime mover, remove the gauges, and install the gauge port plugs. Reconnect the external control input.

Neutral Adjustment (MDC, bottom view)(P005613E)

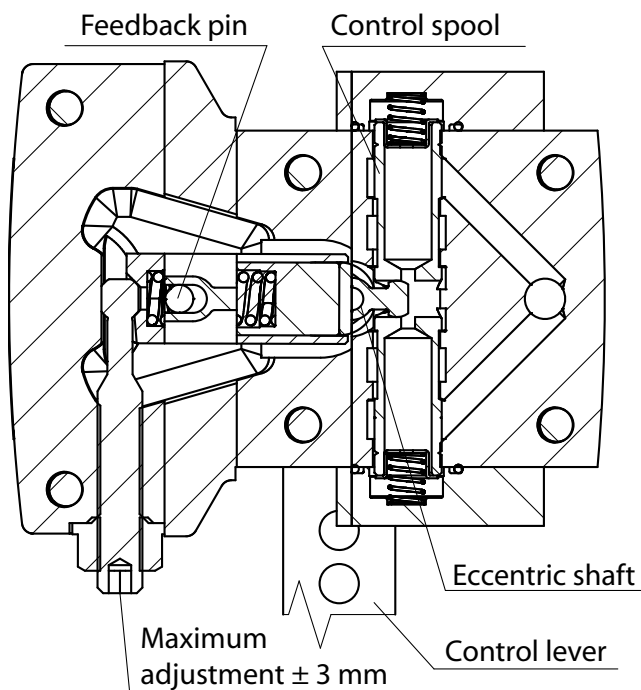

Illustration shows how cam on adjusting pin rotates to adjust for neutral position after pump is re-installed.

A small pressure differential of 0.15 bar [2.2 psi] or less is acceptable. Zero differential is usually not possible.

Mechanical Neutral Adjustment

Mechanical neutral is set with the pump running at 1500 min⁻¹ (rpm). To set neutral, you must stroke the pump in each direction. You can do this with a small movement of the eccentric screw on EDC or MDC controls. To stroke a pump with EDC, you must provide a 100 Hz PWM signal to the control solenoids. If you perform this adjustment with the pump installed in a vehicle or machine, safely elevate the wheels or disconnect the mechanism to allow safe operation during adjustment.

This procedure details setting neutral for the pump. Alternate M4/M5 and M1/M2 to zero out forward and reverse directions of the unit Refer to the drawing below to identify all ports.

While performing this adjustment, you will monitor the following pressures.

- Servo pressure at M4 and M5
- System pressure at M1 and M2
- Pressure differential between M4 and M5 (optional)
- Pressure differential between A and B (optional)

Adjustments

TMP EDC system pressure gage ports for adjusting the servo neutral position

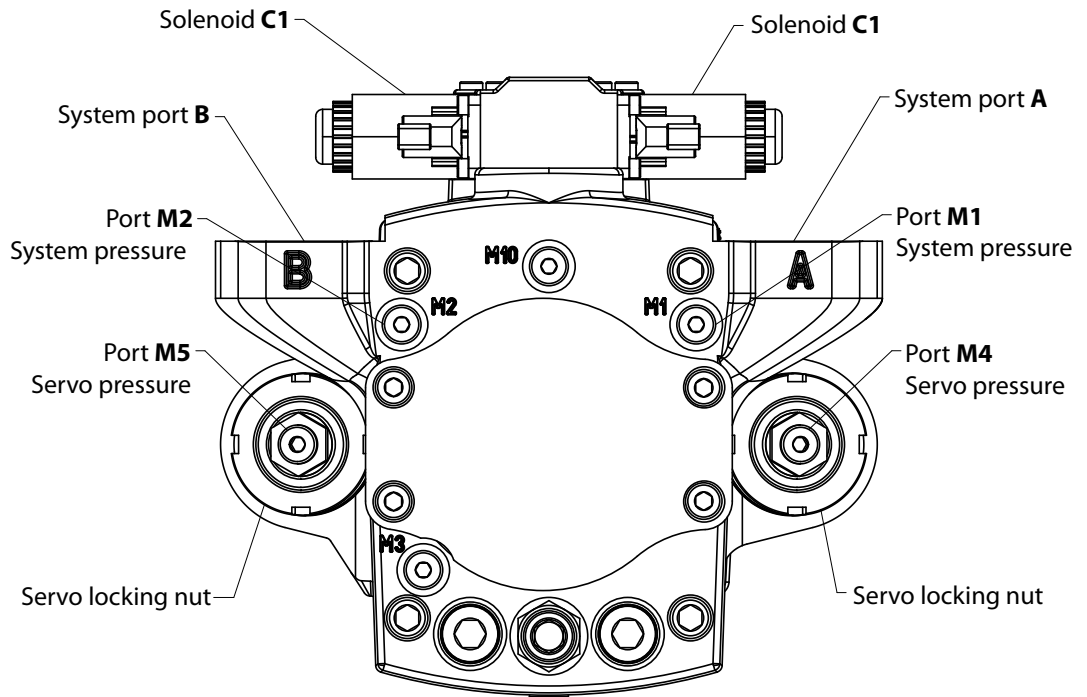

TMP MDC system pressure gage ports for adjusting the servo neutral position

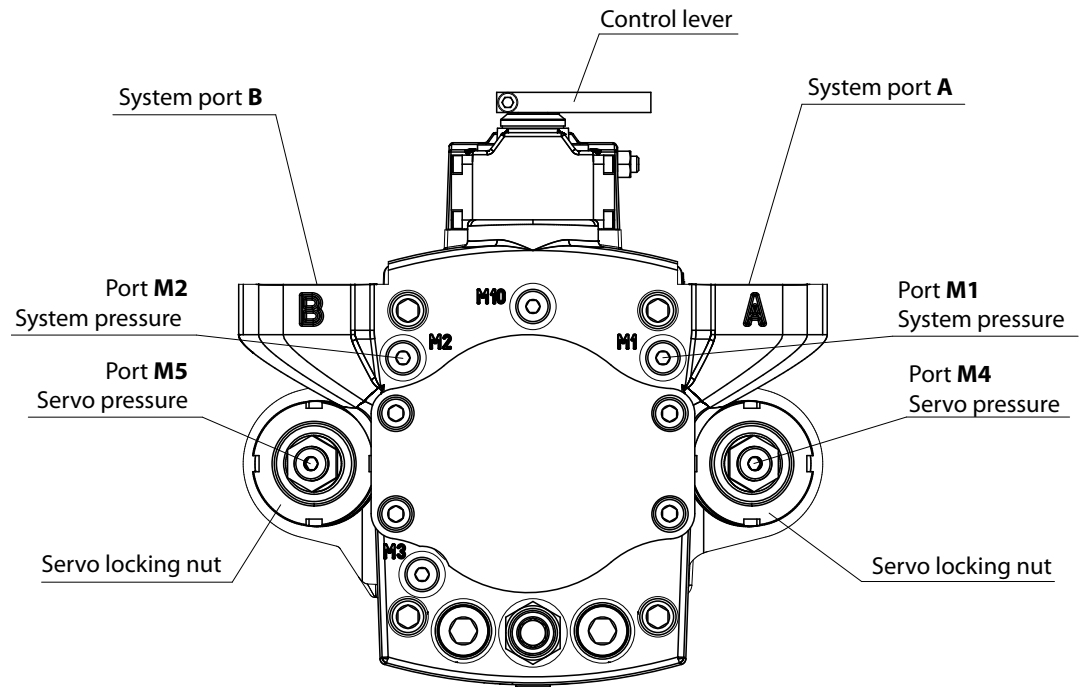

Adjustments

Pump setup

1. Attach a 50 bar [1000 psi] gauge to each servo pressure port M4 and M5. Attach a 600 bar [10 000 psi] gauge to each system pressure port (M1 and M2).
2. Unscrew a nutmutter of the servo cylinder by 2-3 turns.
3. Disconnect the external control input (mechanical or electrical).
4. If using a PWM signal to set mechanical neutral, connect the control solenoids C1 and C2 to the signal source. Ensure the source supplies no current to the solenoids until required in the following procedure.

Servo adjustment

1. Run prime mover at 1500 min^{-1} (rpm).
2. If using a PWM signal TMP with EDC, ensure the signal is off. Check the servo pressure gauges. Ensure the differential between M4 and M5 is less than 1.5 bar [22 psi].
3. Using a SW 24 wrench, unthread both servo cylinders 2-3 turns. This step ensures clearance among the servo cylinders, the servo pistons and swashplate.
4. Stroke the pump by turning the control adjustment screw, or use mechanical or electrical input until the servo pressure at port M4 is 1 to 2 bar [14– 29 psi] greater than at port M5 and the system pressure gauges indicate displacement. Pressure should be greater at port M1 for clockwise rotation, or M2 for counterclockwise rotation. This also indicates the servo cylinder, the servo piston are in the contact with the swashplate on side M
5. Slowly thread the servo cylinder on the M5 side in until the system pressure differential starts to decrease. Maintain servo pressure differential between 1-2 bar [14-29 psi] during this step. Continue turning the servo cylinder in until the system pressure differential (between ports M1/M2) is less than 1.5 bar [22 psi]. This procedure sets the servo and swashplate to mechanical neutral on the M5 side.
6. To complete setting neutral, repeat steps 1-5 but stroke the pump in the opposite direction. Reverse gauge locations (M4 for M5, M2 for M1) from those stated above since the pump is now stroking the other direction.
7. Use a SW 24 wrench to ensure the position of the servo cylinder, and secure the locking nut of the servo cylinder.
8. Remove all gauges and replace gauge port plugs. You can find wrench sizes and plug torques in [Plug Size and Torques](#) on page 43.

Minor Repair

Standard Procedures, Removing the Pump

Before working on the pump, thoroughly clean the outside. If the pump has an auxiliary pump attached, remove both pumps as a single unit. Tag and cap all hydraulic lines as they are disconnected, and plug all open ports to ensure that dirt and contamination do not get into the system.

! Caution

Contamination can damage internal components and void the manufacturer's warranty. Take precautions to ensure system cleanliness when removing and installing system lines.

Disassembly

1. With the prime mover off, thoroughly clean all dirt and grime from the outside of the pump.
2. Tag, disconnect, and cap each hydraulic line connected to the pump. As hydraulic lines are disconnected, plug each open port, to ensure that dirt and contamination do not get into the pump.
3. Remove the pump and its auxiliary pump (if applicable) as a single unit.

Be careful, do not damage solenoids and electrical connections when using straps or chains to support the pump.

Inspection

1. Ensure the work surface and surrounding area are clean and free of contaminants such as dirt and grime.
2. Inspect the system for contamination.
3. Look at the hydraulic fluid for signs of system contamination, oil discoloration, foam in the oil, sludge, or metal particles.

Reassembly

1. Before replacing the pump, replace all filters and drain the hydraulic system. Flush the system lines and fill the reservoir with the correct, filtered hydraulic fluid.
2. Fill the pump with clean, filtered hydraulic fluid.
3. Attach the pump to the prime mover. Torque mounting screws according to the manufacturers recommendation.
4. Replace all hydraulic lines. Ensure the charge inlet line is filled with fluid.

EDC/MDC Control

Removal

Refer to [EDC Control](#) on page 34.

1. Using a 5 mm internal hex wrench, remove the six cap screws (D250).
2. Remove the control module and gasket (D150). Discard the gasket.
3. If necessary, remove orifices (M180, M185) using a 3 mm internal hex wrench. Tag and number them for reinstallation.
4. If screen (D084) is clogged, use a hook to remove retaining ring (D098) and screen. Discard screen and replace with new screen.

Inspection

Inspect the machined surfaces on the control and top of the pump. If you find any nicks or scratches, replace the component.

Reassembly

Ensure you install dowel pins (M140) in housing before installing control.

Minor Repair

1. Install a new gasket (D150).

Proper Screen Orientation

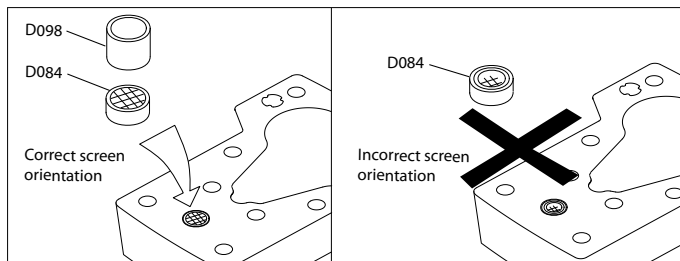

2. If you removed screen (D084), install a new one. Install with the mesh facing outward (see drawing). Install retaining ring (D098).
3. If previously removed, install orifices (M180, M185) using a 3 mm internal hex wrench. Torque to 2.5 N·m [1.8 lbf·ft].
4. Install the control module and six cap screws (D250).
5. Using a 5 mm internal hex wrench, torque the cap screws (D250) to 13.3 N·m [9.8 lbf·ft].

Remove plug on top of control to ensure the swashplate feedback pin is properly positioned in the center of the control module when installing control (for EDC only).

Minor Repair

EDC Control

Control Module and Solenoid Removal/Installation (P005434E)

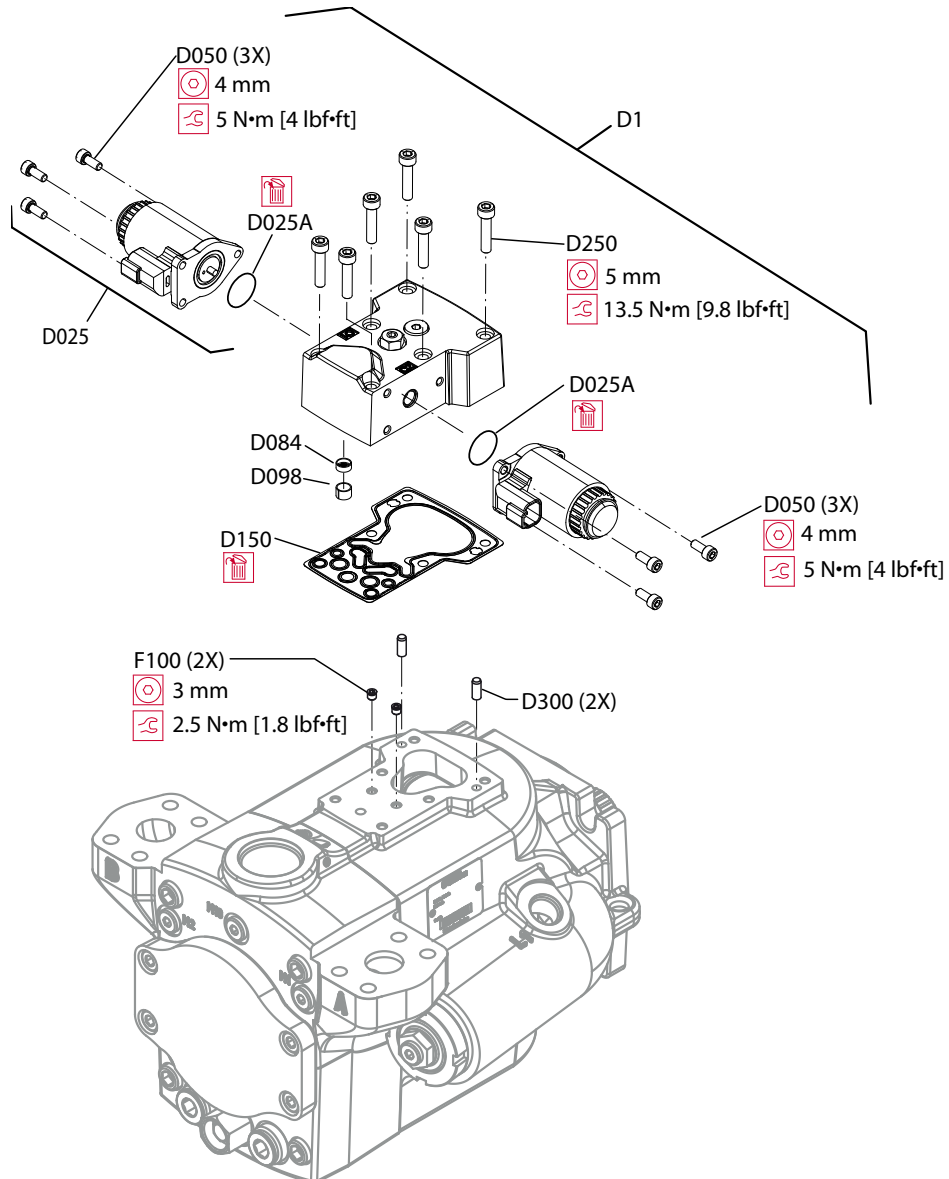

Minor Repair

Torque sequence (P106231)

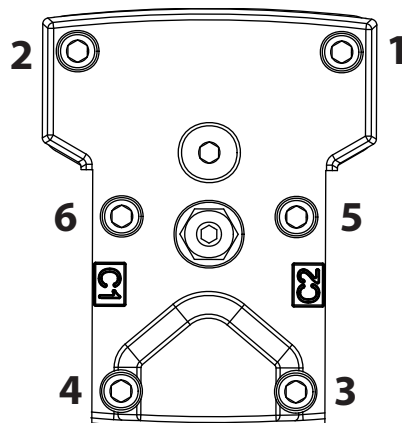

Control Solenoids

Removal

1. Disconnect electrical connection and remove the three cap screws (D050) using a 4mm internal hex wrench.
2. Remove the solenoid (D025) and O-ring (D025A). Discard the O-ring.
3. If necessary, remove the coil using a 12 point 26 mm socket.

Inspection

Inspect the machined surface on the control. If you find any nicks or scratches, replace the component.

Reassembly

1. Lubricate new O-ring (D025A) using petroleum jelly and install.
2. Install solenoid with three cap screws (D050) using a 4 mm internal hex wrench. Torque screws to 5 N·m [4 lbf·ft].
3. Install coil using a 12 point 26 mm socket. Torque coil nut to 5 N·m [3.7 lbf·ft].
4. Reconnect electrical connections and test the pump for proper operation.

Minor Repair

MDC with CCO Control

Control Module and Solenoid Removal/Installation (P005615E)

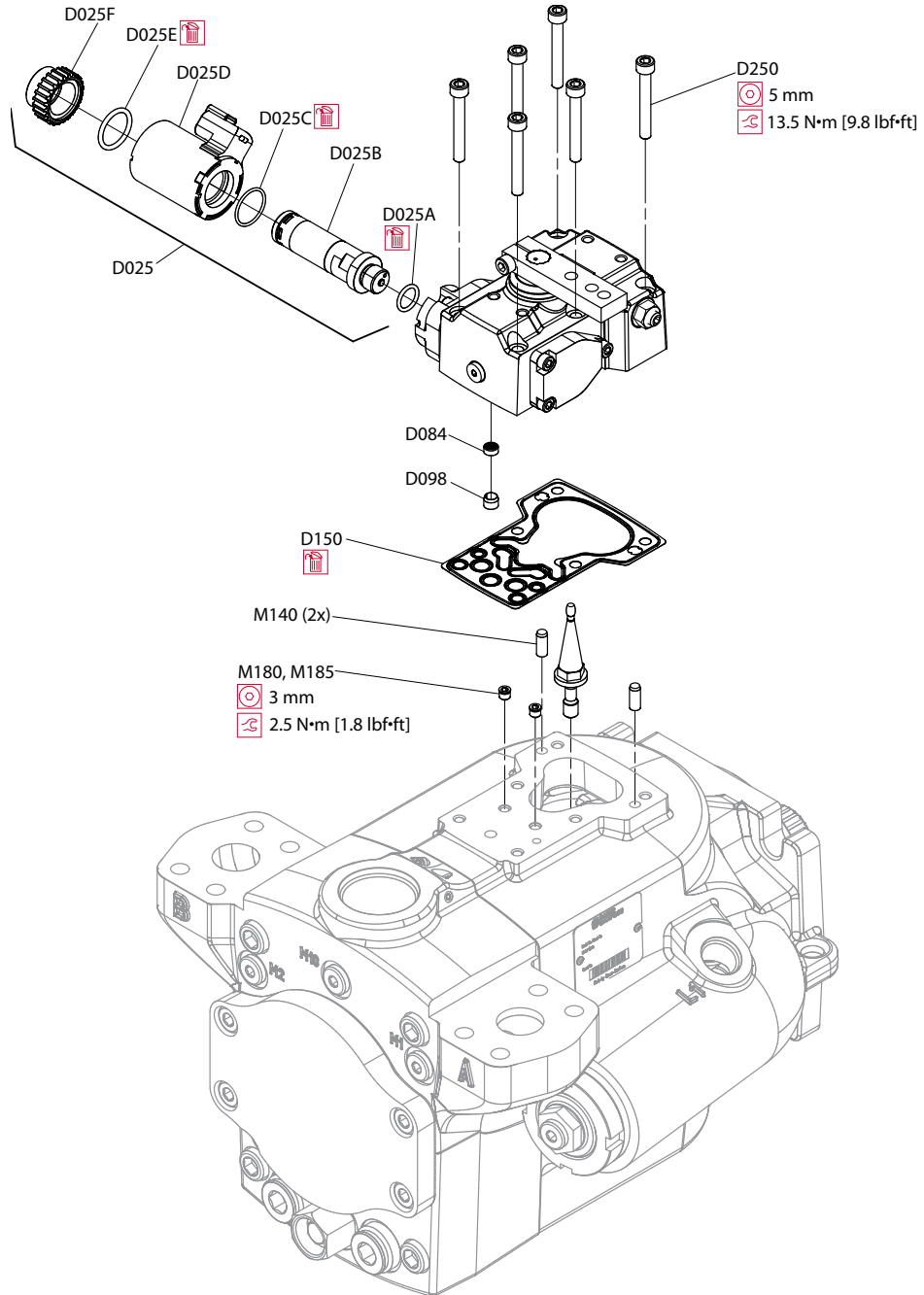

Minor Repair

Torque sequence (P005616)

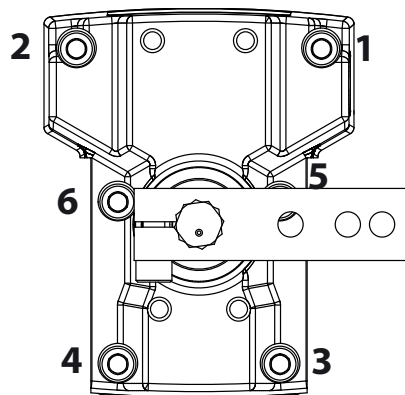

Control Solenoids

Removal

1. Disconnect electrical connection, unscrew the plastic nut (D025F) and remove the coil (D025D) with O-ring (D025E).
2. Remove the center (D025B) and O-rings (D025A and D025C) using a 17 mm internal hex wrench. Discard the O-rings.

Inspection

Inspect the machined surface on the control. If you find any nicks or scratches, replace the component.

Reassembly

1. Lubricate new O-rings (D025A, D025C and D025E) using petroleum jelly and install.
2. Install center (D025B) with O-ring (D025A) using a 17 mm internal hex wrench. Torque to 21 N•m [15.5 lbf•ft].
3. Install coil (D025D) with O-rings (D025C and D025E).
4. Install plastic nut (D025F). Torque to 3.5 N•m [2.5 lbf•ft].
5. Reconnect electrical connections and test the pump for proper operation.

Shaft Seal Replacement

The shaft seal is serviceable. Orient the pump on the work surface so the shaft is pointing up.

Minor Repair

Removal

1. Using snap-ring pliers, remove the outer snap-ring (B110).
2. Press in the seal (L020) down 1 mm and use 2 screwdrivers to remove the carrier (L030) with seal (L020) and O-ring (L040). Discard the seal and O-ring.

Caution

Do not damage the housing bore, shaft or bearing when removing the seal.

Inspection

Inspect the carrier. If you find any defect, replace damaged component.

Reassembly

1. Install the O-ring (L040) and shaft seal (L020) into carrier (L030).
2. Cover end of the shaft with an installation sleeve to protect the seal during installation. Lubricate the seal. Tap on the seal replacing tool or an appropriate deep-socket to press in the seal. Remove the protective cover.
3. Install the remaining snap-ring.

Shaft Seal Assembly (P005449E)

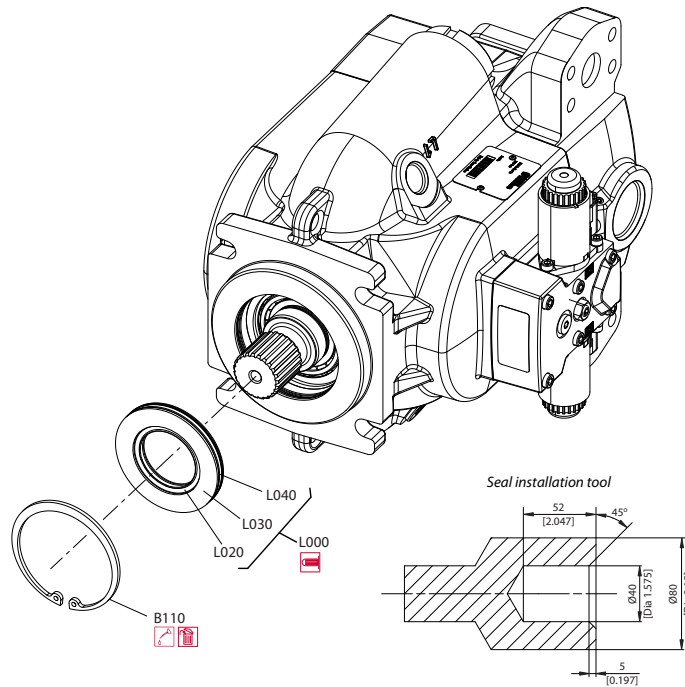

Charge Pump

If the pump has an auxiliary pump attached, remove the auxiliary pump and coupling before removing the auxiliary pad.

Charge Pump Removal (Removable Auxiliary Pad/Cover)

1. Using a 8 mm internal hex wrench, remove cap screws (H050).
2. Remove charge pump cover or auxiliary pad (H030) and O-ring (H045). Discard the O-ring.
3. Remove charge pump coupling (H060) and Woodruff key (H020).

Minor Repair

4. Remove charge pump gearset (H010).

Charge Pump Removal/Installation (P005439E)

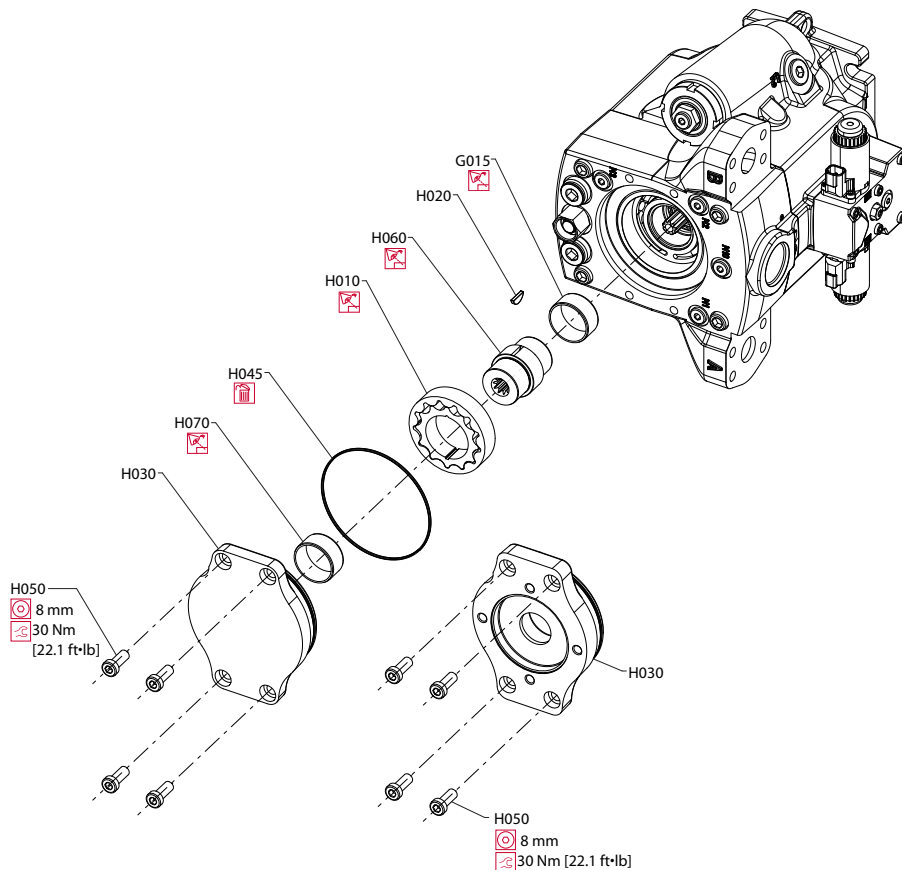

Inspection

Inspect the components for wear, scratches or pitting. Scratches on the gearset, outer ring, cover and end cap surfaces will cause a loss of charge pressure. If any component shows signs of wear, scratching, or pitting, replace it.

Reassembly

1. Lubricate and install charge pump gearset (H010).
2. Install charge pump coupling (H060) and Woodruff key (H020).
3. Install a new O-ring (H045)

Ensure proper torque on aux pad screws (H045). If necessary, replace screws.

4. Install the auxiliary pad or charge pump cover and cap screws. Using a 8 mm internal hex wrench, torque the cap screws (H050) to 30 N·m [22 lbf·ft]. Torque in sequence below.

If charge pump replacement is necessary, replace complete charge pump kit.

Minor Repair

Cover (H030) Torque Sequence (P005438)

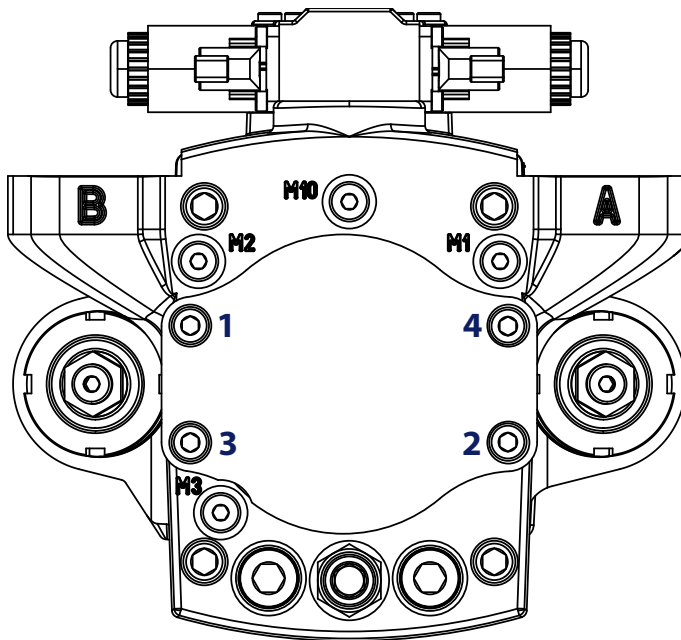

High Pressure Relief Valves (HPRV)

Removal

Using a 12 mm internal hex wrench, remove the HPRVs (G090). Remove and discard the O-rings (G090A).

Inspection

Inspect the sealing surfaces in the pump for nicks or scratches. Check the valves for damage. Replace any damaged components.

Reassembly

1. Lubricate and install new O-rings (G090A).
2. Install HPRVs. Torque to the value 60 N·m [44 lbf·ft].

Minor Repair

3. Operate the vehicle/machine through full range of controls to ensure proper operation. Check for leaks.

HPRVs (P005431)

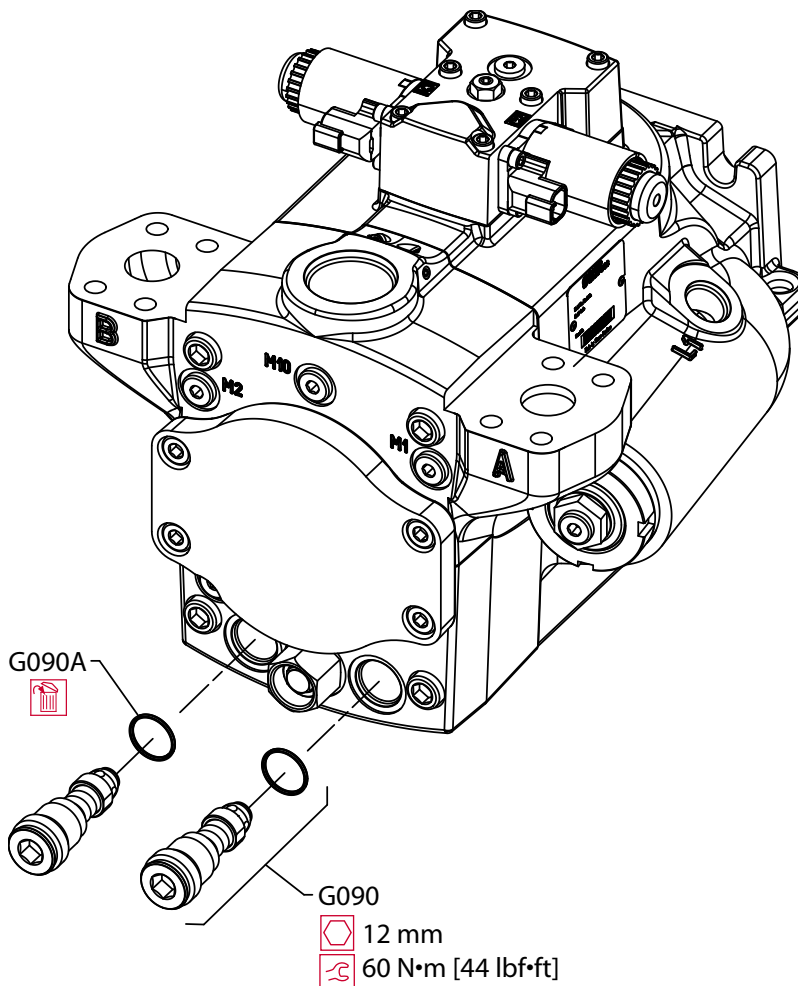

Charge Pressure Relief Valve

Replace the charge pressure relief valve (K001) as a complete unit. Do not attempt to repair the internal components of the valve. Torque to 65 N·m [48 lbf·ft].

See [Charge Pressure Relief Valve Adjustments](#) on page 25 for adjustment instructions.

Removal

Using a 27 mm wrench, remove the charge pressure relief valve (K001). Discard seal O-ring (K050).

Inspection

Inspect the sealing surfaces of the pump for nicks or scratches.

Reassembly

1. Lubricate and install new seal O-ring (K050).
2. Install the charge pressure relief valve. Torque to 65 N·m [48 lbf·ft].

Minor Repair

3. Operate vehicle/machine through full range of controls to ensure proper operation.

Charge Pressure Relief Valve (P005620)

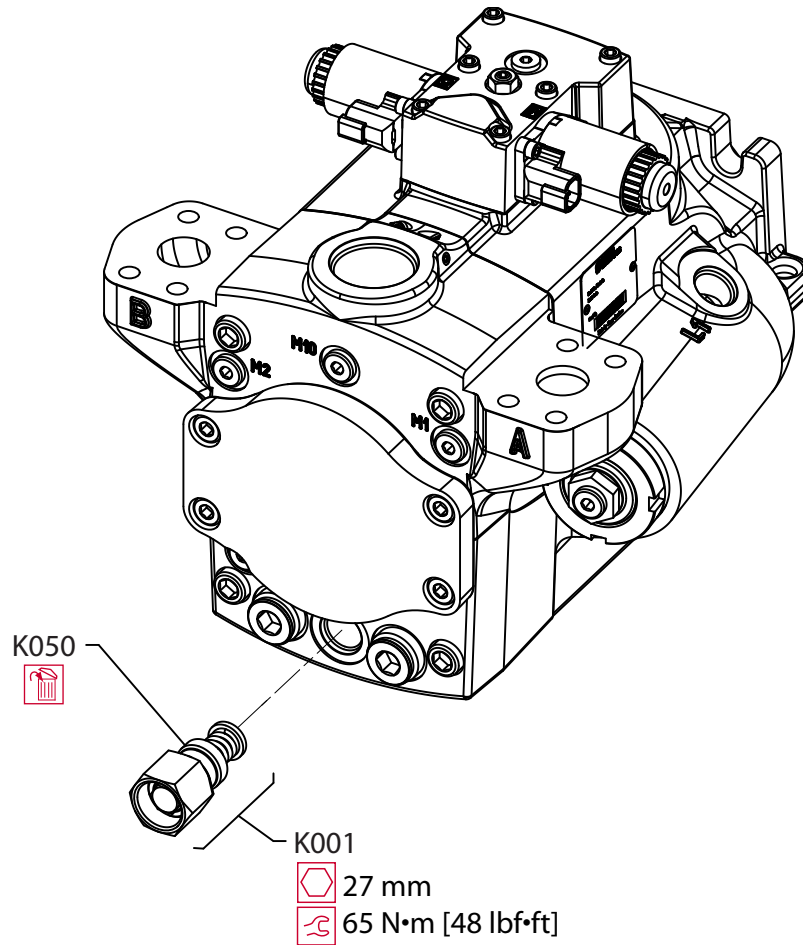

Torque Chart

Fastener Size and Torques

Item	Fastener	Wrench size	Torque
D015	Neutral adjust screw	4 mm internal hex	NA
D050	Coil mounting bolt	4 mm internal hex	8 N•m [6 lbf•ft]
D060	Neutral adjust locking nut	13 mm	10 N•m [7.5 lbf•ft]
D200	Swash plate feedback pin (not shown)	13 mm deep well socket	25 N•m [18 lbf•ft]
D250	Electric control mounting bolt	5 mm internal hex	13.3 N•m [9.8 lbf•ft]
F080	Servo cylinder locking nut	58-62 hook wrench	80 N•m [59 lbf•ft]
M180, M185	Orifice	3 mm internal hex	2.5 N•m [1.84 lbf•ft]
G090	High pressure relief valve	12 mm internal hex	60 N•m [44 lbf•ft]
G100	Rear cover	10 mm internal hex	110 N•m [81 lbf•ft]
H050	Charge Pump Cover Screw	8 mm internal hex	30 N•m [22 lbf•ft]
H080	Auxiliary pad mounting bolt	8 mm internal hex	30 N•m [22 lbf•ft]
K001	Charge pressure adjusting screw	13 mm hex deep socket	NA
	Charge pressure locking nut	27 mm	65 N•m [48 lbf•ft]
W055	Speed sensor mounting bolt	5 mm internal hex	8 N•m [6 lbf•ft]

Plug Size and Torques

Item	O-ring plug	Wrench size	Torque
D065	7/16 - 20	3/16 internal hex	12 N•m [9 lbf•ft]
B030	M22x1.5	10 mm internal hex	40 N•m [29.5 lbf•ft]
G050, F090	M12x1.5	6 mm internal hex	21 N•m [15.5 lbf•ft]

EDC Fasteners and Plugs

P005433E

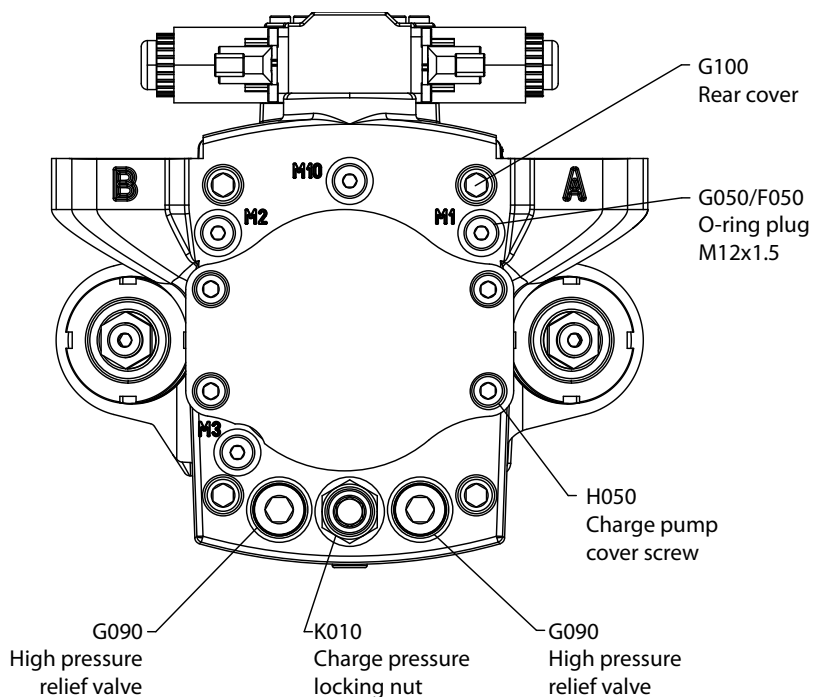

Torque Chart

P005432E

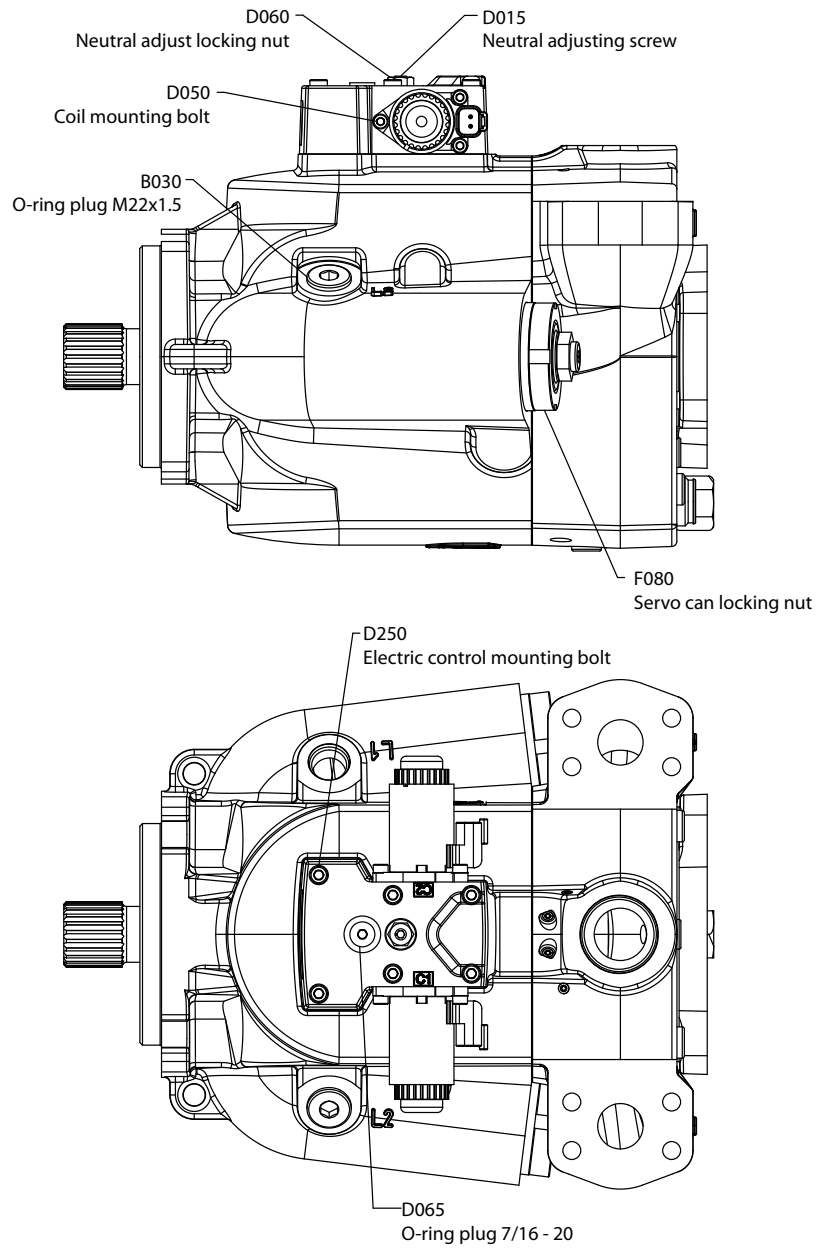

Torque Chart

MDC Fasteners and Plugs

P005617E

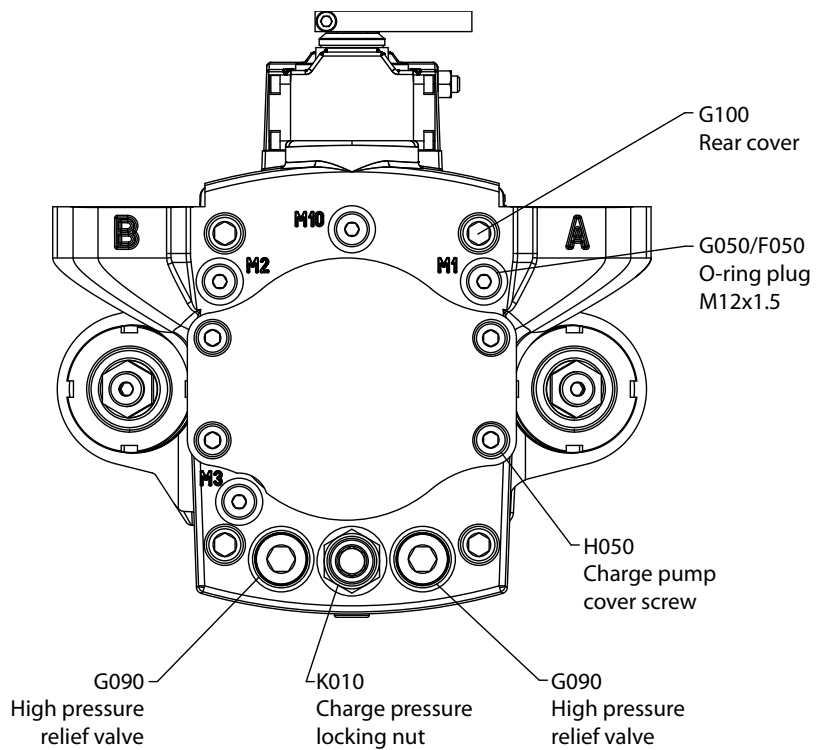

Torque Chart

P005618E

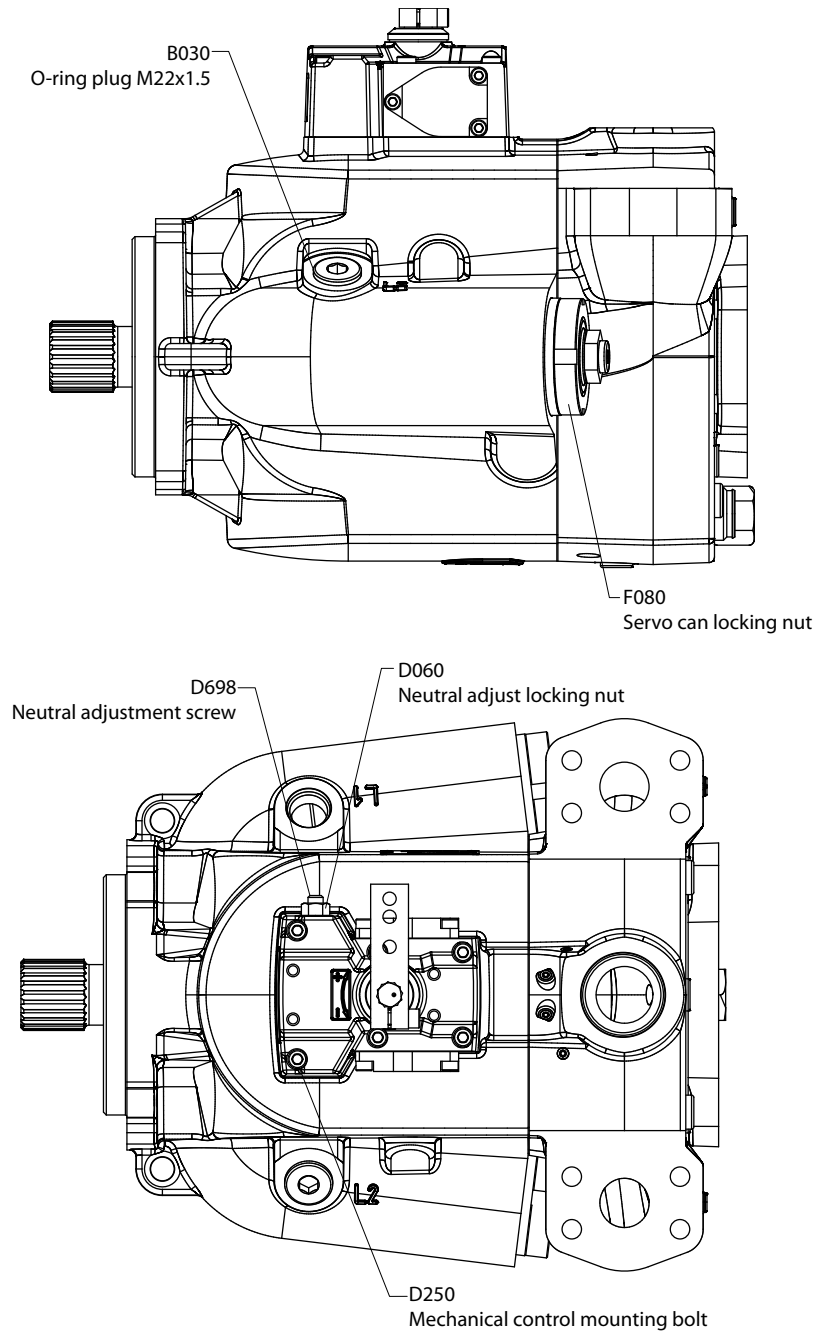

Products we offer:

- Bent Axis Motors
- Closed Circuit Axial Piston Pumps and Motors
- Displays
- Electrohydraulic Power Steering
- Electrohydraulics
- Hydraulic Power Steering
- Integrated Systems
- Joysticks and Control Handles
- Microcontrollers and Software
- Open Circuit Axial Piston Pumps
- Orbital Motors
- PLUS+1® GUIDE
- Proportional Valves
- Sensors
- Steering
- Transit Mixer Drives

Danfoss Power Solutions is a global manufacturer and supplier of high-quality hydraulic and electronic components. We specialize in providing state-of-the-art technology and solutions that excel in the harsh operating conditions of the mobile off-highway market. Building on our extensive applications expertise, we work closely with our customers to ensure exceptional performance for a broad range of off-highway vehicles.

We help OEMs around the world speed up system development, reduce costs and bring vehicles to market faster.

Danfoss – Your Strongest Partner in Mobile Hydraulics.

Go to www.powersolutions.danfoss.com for further product information.

Wherever off-highway vehicles are at work, so is Danfoss. We offer expert worldwide support for our customers, ensuring the best possible solutions for outstanding performance. And with an extensive network of Global Service Partners, we also provide comprehensive global service for all of our components.

Please contact the Danfoss Power Solution representative nearest you.

Comatrol

www.comatrol.com

Turolla

www.turollaocg.com

Hydro-Gear

www.hydro-gear.com

Daikin-Sauer-Danfoss

www.daikin-sauer-danfoss.com

Local address:

Danfoss Power Solutions (US) Company
2800 East 13th Street
Ames, IA 50010, USA
Phone: +1 515 239 6000

Danfoss Power Solutions GmbH & Co. OHG
Krokamp 35
D-24539 Neumünster, Germany
Phone: +49 4321 871 0

Danfoss Power Solutions ApS
Nordborgvej 81
DK-6430 Nordborg, Denmark
Phone: +45 7488 2222

Danfoss Power Solutions Trading (Shanghai) Co., Ltd.
Building #22, No. 1000 Jin Hai Rd
Jin Qiao, Pudong New District
Shanghai, China 201206
Phone: +86 21 3418 5200

Danfoss can accept no responsibility for possible errors in catalogues, brochures and other printed material. Danfoss reserves the right to alter its products without notice. This also applies to products already on order provided that such alterations can be made without changes being necessary in specifications already agreed. All trademarks in this material are property of the respective companies. Danfoss and the Danfoss logotype are trademarks of Danfoss A/S. All rights reserved.