

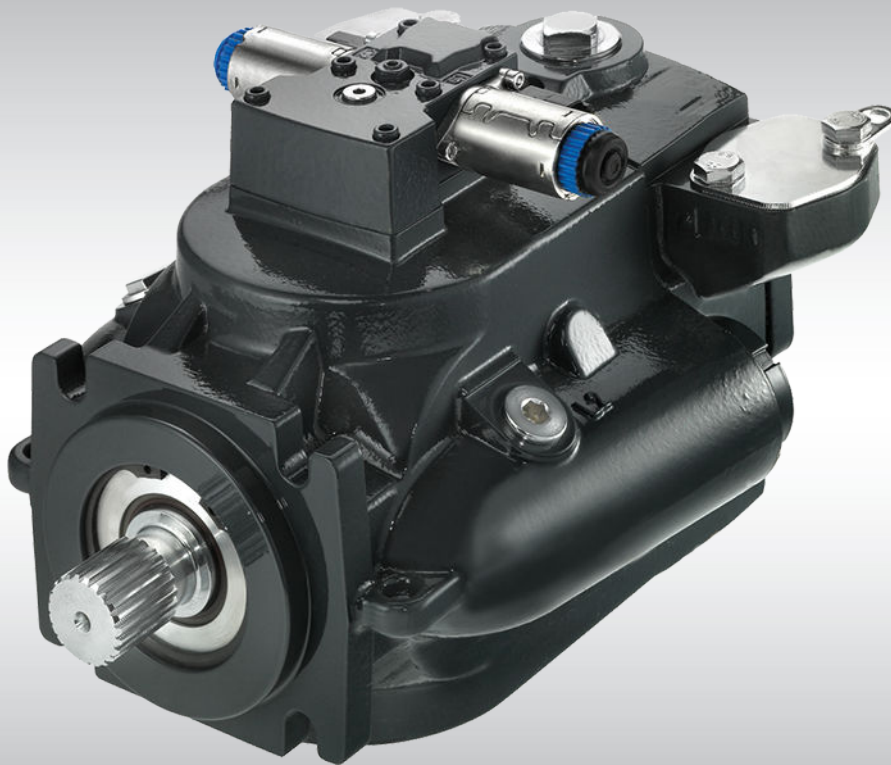

Technical Information

Transit Mixer Axial Piston Pump Size 070/089



Revision History*Table of Revisions*

Date	Changed	Rev
Mar 2014	Converted to Danfoss layout – DITA CMS	CE
Dec 2012	Formulae change, Paragraph move	CD
Nov 2012	Table data	CC
Aug 2012	Illustration, pages swapped	CB
Jul 2012	Major update - The MDC control added	CA
Oct 2011	Images and table data change	BC
Sep 2011	MMC change - option "G" added, 3 "Special Hardware" deleted	BB
Jul 2011	Major update	BA
Sep 2010	Table data for "Control current"	AC
Aug 2010	New Backpage	AB
Jun 2010	First edition	AA

Contents
Description
General information

Features.....	5
System schematics.....	5

Technical specifications

General specification.....	7
Technical data.....	7
Operating parameters.....	8
Input speed.....	8
System pressure.....	8
Charge pressure.....	9
Charge pump inlet pressure.....	9
Case pressure.....	9
External shaft seal pressure.....	9
Hydraulic fluid specifications.....	9
Temperature.....	9
Viscosity.....	9
Filtration.....	10
Case Drain.....	11
Reservoir.....	11
Determination of nominal pump sizes.....	11
Master model code.....	12
High Pressure Relief Valve (HPRV).....	13
Charge Pressure Relief Valve (CPRV)	14
Charge Pump.....	14
Charge pump flow and power curves.....	14
Electrical Displacement Control (EDC), options 12 V/24 V.....	15
EDC principle.....	15
Control signal requirements.....	16
Control response.....	16
Manual Displacement Control (MDC).....	17
MDC principle.....	17
MDC with Control Cut-Off (CCO) – principle.....	18
Manual Over Ride (MOR).....	19
Speed sensor description.....	20

Operation

Bearing life.....	21
Bearing life with no external shaft side load.....	21
External radial shaft loads.....	21
Mounting flange loads.....	22
Estimating overhung load moments.....	22
Input shafts.....	23
Auxiliary mounting pads.....	24
ISO 3019-1, flange 82-2 (SAE A, 9-teeth).....	24
ISO 3019-1, flange 101-2 (SAE B, 13-teeth).....	25
ISO 3019-1, flange 101-2 (SAE B-B, 15-teeth).....	25

Installation drawings

TMP EDC dimensions.....	26
EDC dimensions.....	28
TMP MDC dimensions.....	29
MDC dimensions.....	31
TMP MDC with Control Cut-Off (CCO) dimensions.....	32

Description

The TMP axial variable displacement pump is designed primarily to be combined with other motors in closed circuit systems to transfer hydraulic power.

It is a compact and high power density pump with integral electro-hydraulic or manual control which regulates rate (speed) and direction of the hydraulic flow.

The pump is designed especially for transit mixer applications, where the unique user-friendly design provides simple assembling and service for customers.

TMP EDC



TMP MDC

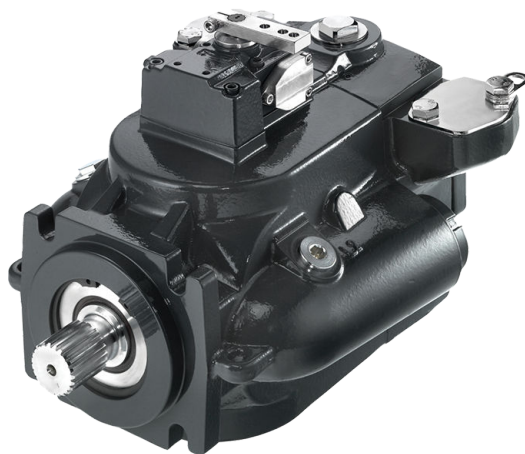

General information
Features

- Innovative reliable design, using the latest technology
- All interfaces accessible from one side (on the top), user friendly
- Load independent displacement control:
 - Electric Displacement Control (EDC)
 - Manual Displacement Control (MDC)
- Pump and Controls with Manual Overrides
- MDC including Emergency stop valve with function Cut off (CCO)
- Spline and coupling shaft configurations available
- Proven rotating group reliability
- Integrated high pressure relief valves
- Optional speed and temperature sensor
- Available metric connections
- TMP is compatible with the Danfoss family of PLUS+1® compliance technology for easy 'Plug-and-Perform' installation.

System schematics

The schematic below shows the function of a hydrostatic transmission using a TMP axial variable displacement pump with electric proportional displacement control (EDC) and a TMM fixed displacement motor with integrated loop flushing device. Detailed information about ports see the section [Installation drawings](#).

TMP EDC with TMM

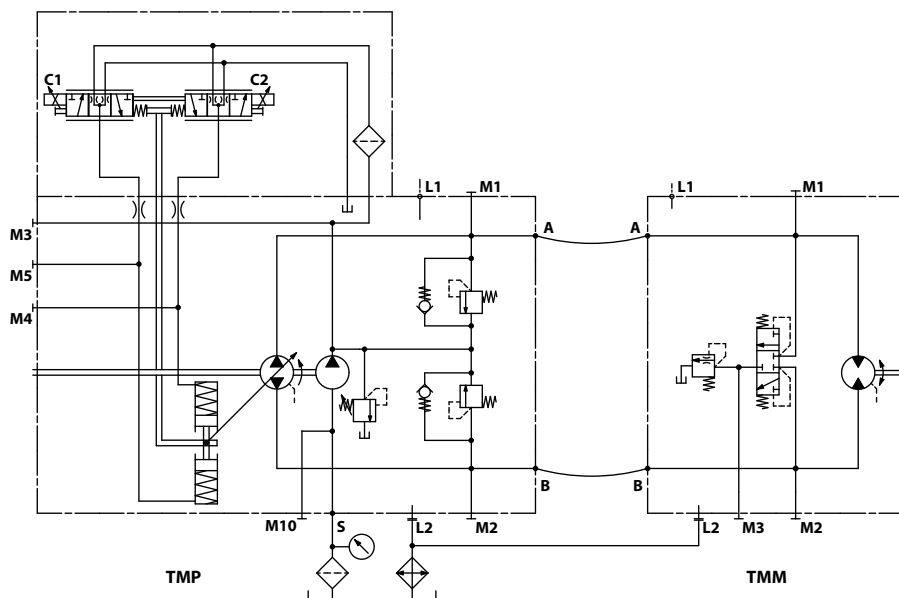

Legend:

A, B – System ports

L1, L2 – Case drain ports

M1, M2 – System A/B gage ports

M3 – Charge gage port, after filtering

M4, M5 – Servo gage ports

M10 – Charge pump inlet pressure port

S – Charge inlet port

General information

The schematic below shows the function of a hydrostatic transmission using a TMP axial variable displacement pump with manual proportional displacement control (MDC) and a TMM fixed displacement motor with integrated loop flushing device.

TMP MDC with TMM

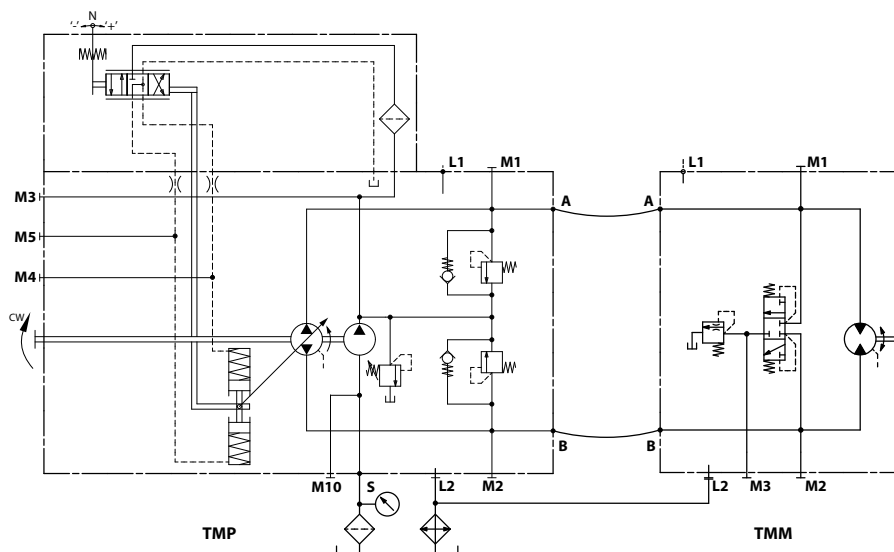

Legend:

A, B – System ports

L1, L2 – Case drain ports

M1, M2 – System A/B gage ports

M3 – Charge gage port, after filtering

M4, M5 – Servo gage ports

M10 – Charge pump inlet pressure port

S – Charge inlet port

Technical Information TMP Transit Mixer Axial Piston Pump, Size 070/089

Technical specifications

General specification

General specifications

Design	Axial piston pump cradle swashplate design with variable displacement
Direction of rotation	Clockwise, counterclockwise
Pipe connections	Main pressure ports: ISO split flange boss Remaining ports: ISO straight thread O-ring boss
Recommended installation position	Pump installation position is discretionary; however the recommended control position is on the top. The housing must always be filled with hydraulic fluid. Pump shaft connection is discretionary, however it is strongly recommended to use rubber coupling if pump is driven via "cardan" shaft. Correct installation has a significant influence on a life time of the pump.

Caution

The front shaft seal must not be exposed to oil pressure from outside of the unit.

Boundary position of the MDC lever must be fixed by hard stop on the customer actuation mechanism in order to prevent any damages of MDC.

Technical data

Features	Unit	Size	
		070	089
Displacement maximum	cm ³ [in ³]	68.3 [4.17]	89.0 [5.43]
Flow at rated (continuous) speed	l/min [US gal/min]	171 [45.2]	222.5 [58.8]
Torque at maximum displacement (theoretical)	N·m/bar [lbf·in/1000 psi]	1.09 [665]	1.42 [867]

Mass moment of inertia of rotating components	0.0209 kg·m ² [0.0159 lbf·ft ²]
Weight dry (standard)	61 kg [135 lb]
Oil volume	2 l [0.53 US gal]
Mounting flange	SAE ISO 3019/1 flange 127-4 (SAE C)
Input shaft	Spline shaft SAE, 21 teeth, pitch = 16/32 Spline shaft SAE, 23 teeth, pitch = 16/32 Coupling flange Ø100 mm for Cardan, 23 teeth (only with spline shaft SAE, 23 teeth, pitch = 16/32)
Auxiliary mounting flange with metric fasteners, shaft splines	SAE A, 11 teeth, pitch = 16/32 SAE B, 13 teeth, pitch = 16/32 SAE B-B, 15 teeth, pitch = 16/32
Suction port	ISO 6149-1 – M42x2 (O-ring boss)
Main port configuration	Twin ports SAE J518b size 1, with metric screws M12
Case drain ports L1, L2	ISO 6149-1 – M22x1,5 (O-ring boss)
Other ports	ISO 6149-1 straight thread O-ring boss. See Installation drawings .

Technical specifications
Operating parameters
Operating parameters, size 070 / 089

Features		Unit	Sizes 070 / 089
Input speed	Minimum	min ⁻¹ (rpm)	500
	Rated		2500
	Maximum		2900
System pressure	Max. working pressure	bar [psi]	420 [6090]
	Maximum pressure		450 [6525]
	Minimum pressure		10 [145]
Charge pressure	Minimum	bar [psi]	17 [247]
	Maximum		30 [436]
Control pressure	Minimum (at corner power for EDC)	bar [psi]	21 [305]
	Maximum		30 [435]
Charge pump inlet pressure	Rated	bar (absolute) [in Hg vacuum]	0.7 [9]
	Minimum (cold start)		0.2 [24]
	Maximum		4 [58]
Case pressure	Rated	bar [psi]	3 [44]
	Maximum		5 [73]
Lip seal external pressure	Maximum	bar [psi]	0.4 [5.8]

Input speed

Minimum speed is the lowest input speed recommended during engine idle condition. Operating below minimum speed limits the pump's ability to maintain adequate flow for lubrication and power transmission.

Rated speed is the highest input speed recommended at full power condition. Operating at or below this speed should yield satisfactory product life.

Maximum speed is the highest operating speed permitted. Exceeding maximum speed reduces product life and can cause loss of hydrostatic power and braking capacity. Never exceed the maximum speed limit under any operating conditions.

System pressure

Maximum working pressure is the highest recommended application pressure; and it is not intended to be a continuous pressure. Propel systems with application pressures at, or below, this pressure should yield satisfactory unit life given proper component sizing.

Maximum pressure is the highest allowable application pressure under any circumstance. Application pressures above maximum working pressure will only be considered with duty cycle analysis and factory approval.

 Caution

Minimum pressure must be maintained under all operating conditions to avoid cavitation.

Technical specifications

Charge pressure

Minimum charge pressure is the lowest pressure allowed to maintain a safe working condition in the low side of the loop.

Maximum charge pressure is the highest charge pressure allowed by the charge relief adjustment, which provides normal component life.

Charge pump inlet pressure

Minimum charge inlet pressure is only allowed at cold start conditions. In some applications it is recommended to warm up the fluid (e.g. in the tank) before starting the engine and then run the engine at limited speed. Maximum charge pump inlet pressure may be applied continuously.

Caution

At normal operating temperature, charge inlet pressure must not fall below rated charge inlet pressure (vacuum).

Case pressure

Under normal operating conditions, the rated case pressure must not be exceeded. During cold start, case pressure must be kept below maximum intermittent case pressure.

External shaft seal pressure

The shaft seal is designed to withstand an external pressure up to 0.4 bar [5.8 psi] above the case pressure. In certain applications, the input shaft seal may be exposed to external pressures.

Caution

The case pressure limits must be followed to ensure the shaft seal is not damaged.

Hydraulic fluid specifications

Temperature

High temperature limits apply at the inlet port of the motor. The motor should run at or below the maximum continuous temperature.

Cold oil generally does not affect the durability of motor components. It may affect the ability of oil to flow and transmit power. For this reason, keep the temperature at 16°C [60 °F] above the pour point of the hydraulic fluid.

Minimum temperature (cold start) relates to the physical properties of component materials.

Maximum continuous temperature is the allowed temperature at which normal life can be expected.

Peak temperature (intermittent) is the overheating temperature tolerable by the machine for a transient/limited time.

Viscosity

Minimum viscosity occurs only during brief occasions of maximum ambient temperature and severe duty cycle operation. It's the minimum acceptable viscosity to allow normal motor life.

Maximum viscosity occurs only during cold start at very low ambient temperatures. It's the upper limit of viscosity that allows the motor to start.

Temperature and viscosity requirements must be concurrently satisfied. Use petroleum/mineral-based fluids.

Technical specifications
Fluid specifications

Features		Unit	Sizes 070 / 089
Viscosity	Intermittent ¹⁾	mm ² /s [SUS]	5 [42]
	Minimum		7 [49]
	Recommended range		12-80 [66-370]
	Maximum		1600 [7500]
Temperature range ²⁾	Minimum (cold start) ³⁾	°C [°F]	-40 [-40]
	Recommended range		60-85 [140-185]
	Rated		104 [220]
	Maximum intermittent ¹⁾		115 [240]
Filtration (recommended minimum)	Cleanliness per ISO 4406		22/18/13
	Efficiency (charge pressure filtration)	β-ratio	β ₁₅₋₂₀ = 75 (β ₁₀ ≥ 10)
	Efficiency (suction and return line filtration)		β ₃₅₋₄₅ = 75 (β ₁₀ ≥ 2)
	Recommended inlet screen mesh size	μm	100 – 125

¹⁾ Intermittent = Short term t < 1 min per incident and not exceeding 2 % of duty cycle based load-life.

²⁾ At the hottest point, normally case drain port.

³⁾ Cold start = Short term t < 3 min, p ≤ 50 bar [725 psi], n ≤ 1000 min⁻¹ (rpm).

Filtration

To prevent premature wear, ensure only clean fluid enters the hydrostatic transmission circuit. A filter capable of controlling the fluid cleanliness to ISO 4406 class 22/18/13 (SAE J1165) or better, under normal operating conditions, is recommended.

These cleanliness levels can not be applied for hydraulic fluid residing in the component housing/case or any other cavity after transport.

Filtration strategies for TMP include only suction filtration. The selection of a filter depends on a number of factors including the contaminant ingress rate, the generation of contaminants in the system, the required fluid cleanliness, and the desired maintenance interval. Filters are selected to meet the above requirements using rating parameters of efficiency and capacity.

Filter efficiency can be measured with a **Beta ratio (βX)**. Filter βX-ratio is a measure of filter efficiency defined by ISO 4572. It is defined as the ratio of the number of particles greater than a given diameter (“x” in microns) upstream of the filter to the number of these particles downstream of the filter.

For simple suction-filtered closed circuit transmissions and open circuit transmissions with return line filtration, a filter with a β-ratio within the range of β₃₅₋₄₅ = 75 (β₁₀ ≥ 2) or better has been found to be satisfactory.

For some open circuit systems, and closed circuits with cylinders being supplied from the same reservoir, a considerably higher filter efficiency is recommended. This also applies to systems with gears or clutches using a common reservoir.

For these systems, a charge pressure or return filtration system with a filter β-ratio in the range of β₁₅₋₂₀ = 75 (β₁₀ ≥ 10) or better is typically required.

Because each system is unique, only a thorough testing and evaluation program can fully validate the filtration system. Please see *Design Guidelines for Hydraulic Fluid Cleanliness Technical Information, 520L0467* for more information.

Technical specifications
Case Drain

All TM pumps are equipped with two case drain ports. Port selection and case drain routing must enable the pump housing to maintain a volume of oil not less than half full and normal operating case pressure limits of the unit are maintained. Case drain routing and design must consider unit case pressure ratings.

A case drain line must be connected to one of the case outlets to return internal leakage to the system reservoir.

Reservoir

The **reservoir** provides clean fluid, dissipates heat, removes entrained air, and allows for fluid volume changes associated with fluid expansion during system operation. A correctly sized reservoir also accommodates maximum volume changes during all system operating modes. It promotes de-aeration of the fluid as it passes through, and accommodates a fluid dwell-time between 60 and 180 seconds, allowing entrained air to escape.

Minimum reservoir capacity depends on the volume required to cool and hold the oil, allowing for expansion due to temperature changes. A fluid volume of one to three times the motor output flow (per minute) is satisfactory. The minimum recommended reservoir capacity is 125% of the fluid volume.

Put the return-line below the lowest expected fluid level to allow discharge into the reservoir for maximum dwell and efficient de-aeration. A baffle (or baffles) between the return and suction lines promotes de-aeration and reduces fluid surges.

Determination of nominal pump sizes

Use these formulae to determine the nominal pump size for a specific application:

	Based on SI units	Based on US units
<i>Output flow:</i>	$Q = \frac{Vg \cdot n \cdot \eta_v}{1000} \text{ l/min}$	$Q = \frac{Vg \cdot n \cdot \eta_v}{231} \text{ [US gal/min]}$
<i>Input torque:</i>	$M = \frac{Vg \cdot \Delta p}{20 \cdot \pi \cdot \eta_m} \text{ N}\cdot\text{m}$	$M = \frac{Vg \cdot \Delta p}{2 \cdot \pi \cdot \eta_m} \text{ [lbf}\cdot\text{in]}$
<i>Input power:</i>	$P = \frac{M \cdot n}{9550} = \frac{Q \cdot \Delta p}{600 \cdot \eta_t} \text{ kW}$	$P = \frac{M \cdot n}{63\,025} = \frac{Q \cdot \Delta p}{1714 \cdot \eta_t} \text{ [hp]}$

Variables:

	<u>SI units</u>	<u>[US units]</u>
Vg	= Displacement per rev.	cm ³ /rev [in ³ /rev]
p _{HD}	= Outlet pressure	bar [psi]
p _{ND}	= Inlet pressure	bar [psi]
Δp	= p _{HD} – p _{ND}	bar [psi]
n	= Speed	min ⁻¹ (rpm)
η _v	= Volumetric efficiency	
η _m	= Mechanical (torque) efficiency	
η _t	= Overall efficiency (η _v • η _m)	

Technical Information TMP Transit Mixer Axial Piston Pump, Size 070/089
Technical specifications
Master model code

A Product

TMP	Transit Mixer Pump
-----	--------------------

B Frame size / Displacement

070	68.3 cm ³ /rev [4.17 in ³ /rev]
089	89.0 cm ³ /rev [5.43 in ³ /rev]

C Control

EDC024A	Electrical Displacement Control (EDC - 24 V) with Manual Over Ride
EDC012A	Electrical Displacement Control (EDC - 12 V) with Manual Over Ride
MDCNNNN	Manual Displacement Control (MDC)
MDCA24A	MDC with Control Cut-off (CCO - 24 V) and Manual Over Ride

D Sense of rotation

R	Right hand (clockwise)
L	Left hand (counterclockwise)

G End cap ports; High pressure setting

M42	Endcap Ports: DN 25, Type 2, 420 bar (6000 psi), ISO 6162-2; High pressure relief valve 420 bar, (Metric connections)
M28	Endcap Ports: DN 25, Type 2, 420 bar (6000 psi), ISO 6162-2; High pressure relief valve 280 bar, (Metric connections)

H Charge pump; Charge pump relief valve setting

20G22	Charge pump: 20 cm ³ /rev; Charge pump relief valve settings: 20.3-22.5 bar
-------	--

J Auxiliary Mounting Pad

A	ISO 3019-1, flange 82 - 2, (SAE A, 9 teeth 16/32)
B	ISO 3019-1, flange 101 - 2, (SAE B, 13 teeth 16/32)
V	ISO 3019-1, flange 101 - 2, (SAE B-B, 15 teeth 16/32)
N	none

L Shaft

C	Splined shaft, 23 teeth, pitch = 16/32
D	Splined shaft, 21 teeth, pitch = 16/32
G	'C' Shaft option, Added Coupling 23 teeth with flange ø100 mm

Technical specifications
W Special Hardware Features

NCN	No sensor, Valve plate CP30
HCN	Speed & Temperature sensor 53 impulsions (n, direc. T), Valve plate CP30
ACN	KPP156 speed sensor (n, direc.), Valve plate CP30

F Special Features

NSN	No paint, Name plate "Slovakia"
NDN	No paint, Name plate "Danfoss"
BSN	Black paint, Name plate "Slovakia"
BDN	Black paint, Name plate "Danfoss"
GSN	Gray paint, Name plate "Slovakia"
GDN	Gray paint, Name plate "Danfoss"

High Pressure Relief Valve (HPRV)

The TM pumps are equipped with a combination high pressure relief and charge check valve. The high-pressure relief function is a dissipative pressure control valve for the purpose of limiting excessive system pressures.

The charge check function acts to replenish the low-pressure side of the working loop with charge oil. Each side of the transmission loop has a dedicated HPRV valve that is non-adjustable with a factory set pressure.

When system pressure exceeds the factory setting of the valve, oil is passed from the high pressure system loop into the charge gallery, and into the low pressure system loop via the charge check.

The pump order code allows for different pressure settings to be used at each system port.

System schematic, single pump

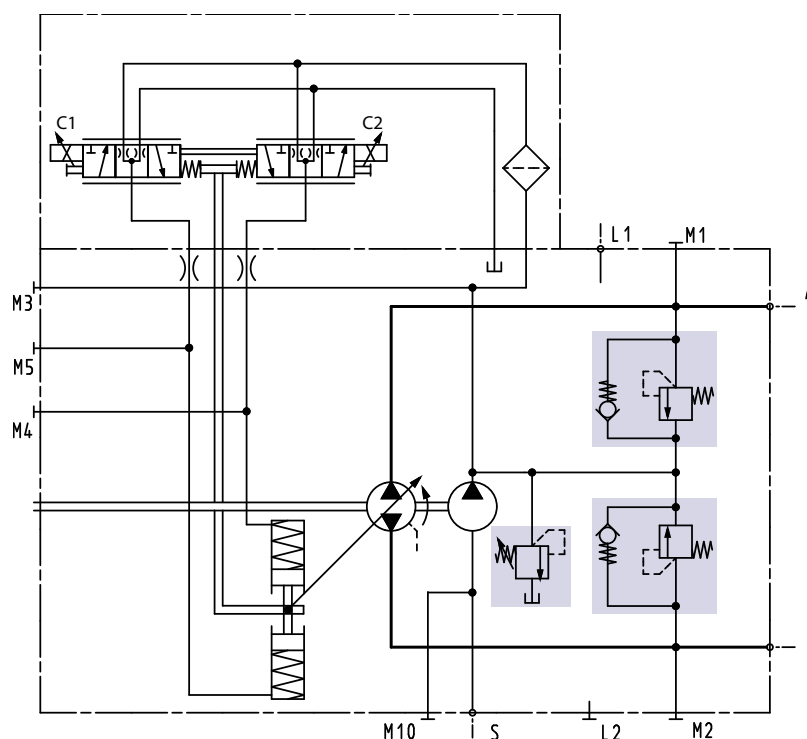

Technical specifications
Charge Pressure Relief Valve (CPRV)

The charge pressure relief valve maintains charge pressure at a designated level above case pressure. The charge pressure relief valve is a direct acting poppet valve which opens and discharges fluid to the pump case when pressure exceeds a designated level. Standard level setting is $\Delta p = 21 \pm 1.1$ bar [304 \pm 16 psi] with the pump running at 1500 rpm and flow = 23.80 - 29.5 l/min [6.3 - 7.8 US gal/min].

Typical charge pressure increase is 2 bar per 10 l/min [29 psi per 2.64 US gal/min].

Charge Pump

Charge flow is required on all pumps applied in closed circuit installations. The charge pump provides flow to make up internal leakage, maintain a positive pressure in the main circuit, provides flow for cooling and filtration, replaces any leakage losses from external valving or auxiliary systems, and provides flow and pressure for the control system.

Charge pump flow and power curves

Charge pressure: 20 bar [290 psi]

Viscosity: 11 mm²/s [63 SUS]

Temperature: 80 °C [180 °F]

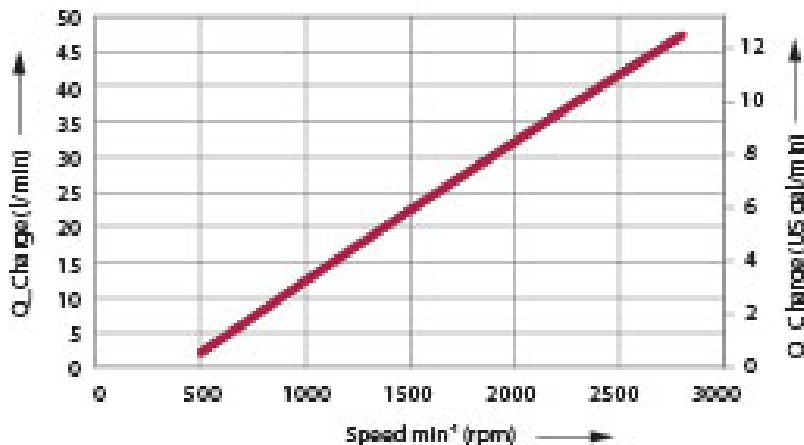
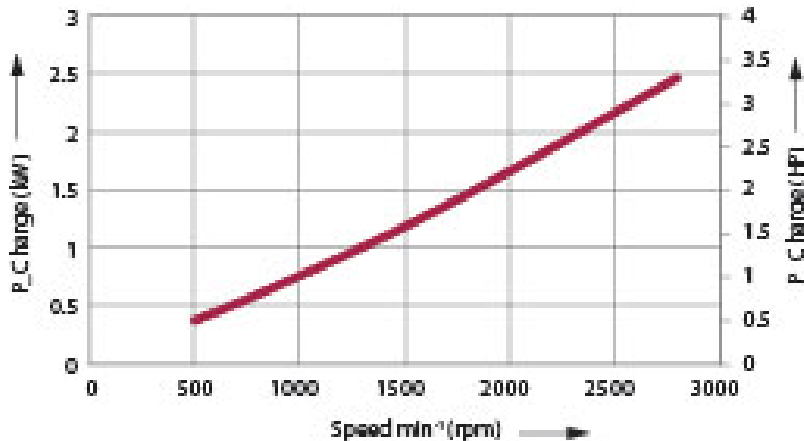
Charge pump flow

Charge pump power requirements

Technical specifications

Electrical Displacement Control (EDC), options 12 V/24 V

EDC principle

The Electrical Displacement Control (EDC) consists of a pair of proportional solenoids on each side of a three-position, four-way porting spool. The proportional solenoid applies a force input to the spool, which ports hydraulic pressure to either side of a double acting servo piston. Differential pressure across the servo piston rotates the swashplate, changing the pump's displacement from full displacement in one direction to full displacement in the opposite direction.

EDC

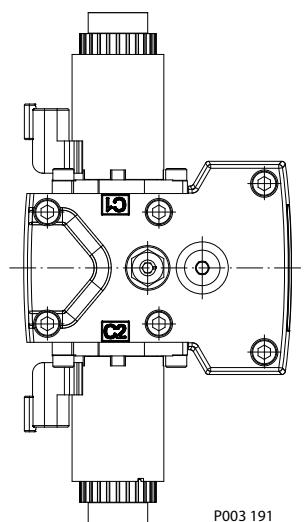

EDC schematic

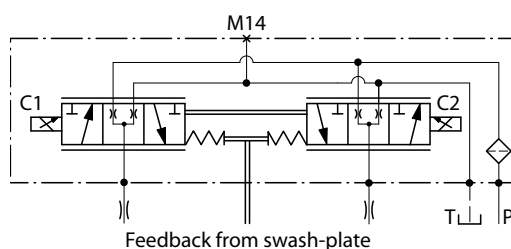

Pump displacement vs. control current

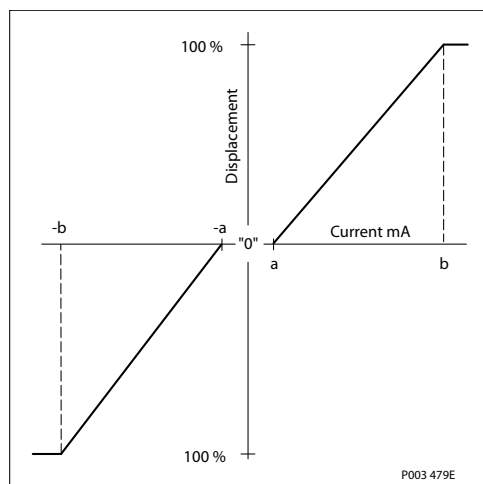

Technical specifications
Control signal requirements
Control current

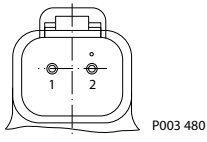
Voltage	a*	b	Pin connections
12 V	650 mA	1600 mA	Connector  any order
24 V	310 mA	810 mA	

* Factory test current, for vehicle movement or application actuation expect higher value.

Available connector models

Description	Quantity
Mating connector - Deutsch® DT06-2S	1
Wedge lock - Deutsch® W2S	1
Socket contact (16 and 18 AWG) - Deutsch® 0462-201-16141	2
Danfoss mating connector kit K29657	1

Solenoid data

Voltage	12V	24V
Maximum current	1800 mA	920 mA
Coil resistance @ 20 °C [70 °F]	3.66 Ω	14.20 Ω
Coil resistance @ 80 °C [176 °F]	4.52 Ω	17.52 Ω
PWM Range	70 – 200 Hz	
PWM Frequency (preferred)*	100 Hz	
Inductance	33 mH	140 mH
IP Rating (IEC 60 529) + DIN 40 050, part 9	IP 67 / IP 69K (with mating connector)	

* PWM signal required for optimum control performance.

Flow table

Shaft rotation	CW		CCW	
Coil energized*	C1	C2	C1	C2
Port A	out	in	in	out
Port B	in	out	out	in
Servo port pressurized	M4	M5	M4	M5

* For coil location see [Installation drawings](#).

Control response

TMP controls are available with optional control passage orifices to assist in matching the rate of swashplate response to the application requirements (e.g. in the event of electrical failure).

Software ramp or rate limiting should be used to control vehicle response in normal operation.

Technical specifications

The time required for the pump output flow to change from zero to full flow (acceleration) or full flow to zero (deceleration) is a net function of spool porting, orifices, and charge pressure.

A swashplate response table is available for each frame indicating available swashplate response times. Testing should be conducted to verify the proper software and orifice selection for the desired response.

TMP pumps are limited in mechanical orificing combinations. Software is envisioned as the means to control the swashplate response in normal operating conditions. Mechanical servo orifices are to be used only for fail-safe return to neutral in the event of an electrical failure.

*Response times**

Stroking direction	No orifice
Neutral to full flow	1.2 s
Full flow to neutral	0.6 s

* at the following conditions:

- $\Delta p = 200 \text{ bar}$ [2900 psi]
- Viscosity = $30 \text{ mm}^2/\text{s}$ [141 SUS]
- Temperature = $50 \text{ }^\circ\text{C}$ [122 $^\circ\text{F}$]
- Charge pressure = 20 bar [290 psi]
- Speed = 1800 min^{-1} (rpm)

Manual Displacement Control (MDC)
MDC principle

The Manual Displacement Control (MDC) consists of a lever with eccentric shaft centre of a three-position, four-way porting spool. The eccentric shaft applies a force input to the spool, which ports hydraulic pressure to either side of a double acting servo piston. Differential pressure across the servo piston rotates the swash plate, changing the pump's displacement from full displacement in one direction to full displacement in the opposite direction.

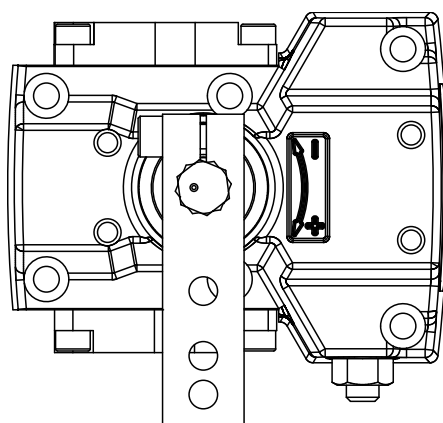
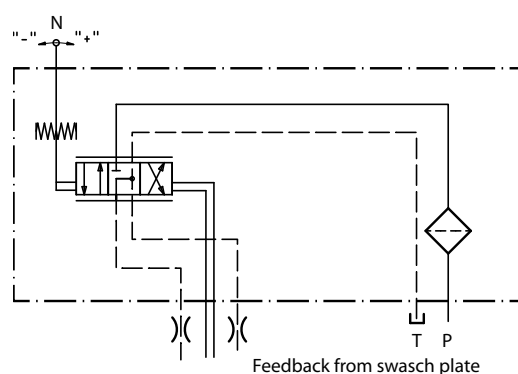
MDC

MDC schematic

Technical specifications

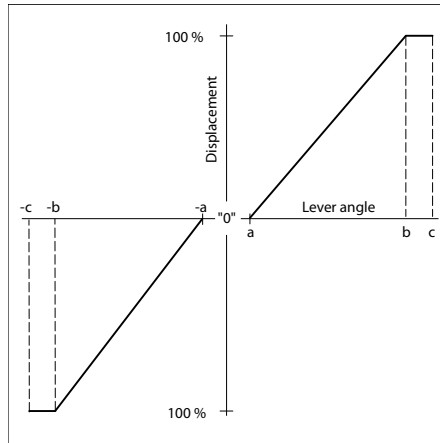
Pump displacement vs. lever angle



Lever angle:

$a = 4^\circ \pm 1^\circ$

$b = 33^\circ \pm 1^\circ$

$c = 40^\circ \text{ max.}$

Customer "Hard Stop" of the lever = $38^\circ + 1^\circ$

Lever torque when displacement goes up:

Start at:	End at:	Maximum allowed torque
max. 1,5 N·m	max. 3 N·m	12 N·m

! Caution

Boundary position of the MDC lever must be fixed by hard stop on the customer actuation mechanism in order to prevent any damages of MDC.

MDC with Control Cut-Off (CCO) – principle

If solenoid is loaded by voltage directly from truck battery 24 to 32 V pump work in normal mode if the electric circuit will by switch off pump will go immediately to 0 position .

MDC with Control Cut-Off (CCO)

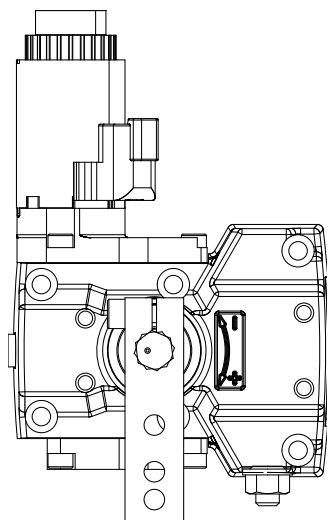

MDC CCO schematic

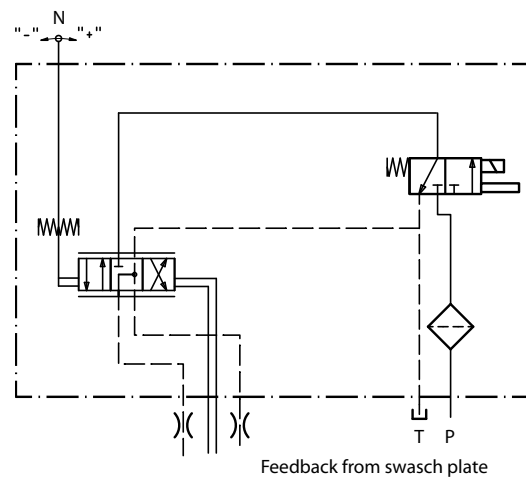

For Connector model, see [Control signal requirements](#).

Technical specifications
Solenoid data

Voltage	24 V
Nominal current	700 mA
Coil resistance @ 20 °C [70 °F]	34.5 Ω
PWM range (PWM signal required for optimum control performance)	70-200 Hz
Inductance	573 mH
IP rating (IEC 60 529) + DIN 40 050, part 9	IP 67
IP rating (IEC 60 529) + DIN 40 050, part 9 with mating connector	IP 69K

Flow table

Shaft rotation	CW		CCW	
	'-'	'+'	'-'	'+'
Lever direction*	'-'	'+'	'-'	'+'
Port A	out	in	in	out
Port B	in	out	out	in
Servo port pressurized	M4	M5	M4	M5

* For lever direction, see [Installation drawings](#).

Manual Over Ride (MOR)

All controls are available with a Manual Over Ride (MOR) either standard or as an option for temporary actuation of the control to aid in diagnostics.

The vehicle or device must always be in a 'safe' condition (i.e. vehicle lifted off the ground) when using the MOR function.

The MOR plunger has a 4 mm diameter and must be manually depressed to be engaged.

Depressing the plunger mechanically moves the control spool which allows the pump to go on stroke.

The MOR should be engaged anticipating a full stroke response from the pump.

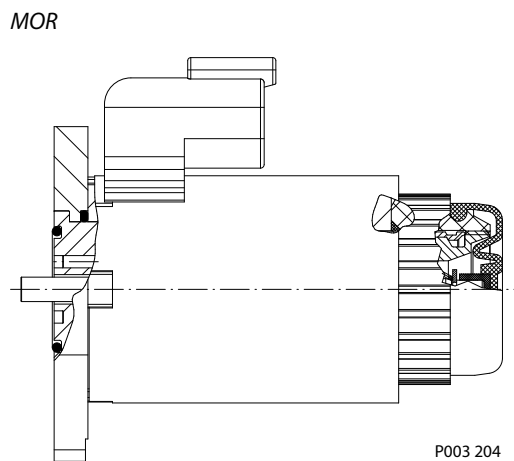

⚠ Warning

An O-Ring seal is used to seal the MOR plunger where initial actuation of the function will require a force of 45 N to engage the plunger. Additional actuations typically require less force to engage the MOR plunger. Proportional control of the pump using the MOR should not be expected.

Refer to control flow table for the relationship of solenoid to direction of flow.

Technical specifications

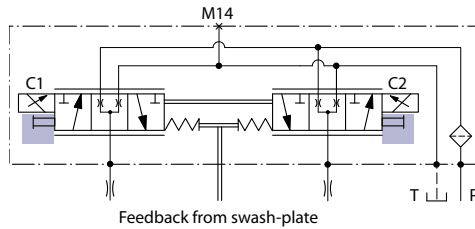
MOR schematic diagram (EDC shown)



MOR schematic diagram (MDC shown)

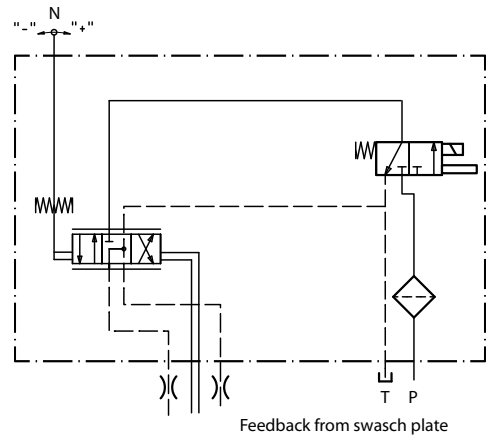

Speed sensor description

Function of the speed sensor is to detect the shaft speed and the direction of rotation. Typically the sensor will be mounted to the housing of a Danfoss pump or motor and senses the speed from a target ring that is rotating inside the pump or motor. Because of the digital output signals for speed and direction and a non speed dependent output voltage level, the sensor is ideal for high and low speed measurements.

For diagnostics and other purposes, the sensor also has the capability to detect the case oil temperature.

The speed sensor is designed for rugged outdoor, mobile or heavy industrial speed sensing applications. The detection of the speed is contactless. It is custom-designed for Danfoss. It is a “plug and perform” device that does not need any calibration or adjustments.

Connector data

Connector model	Deutsch DTM-Series 6-Pin DTM06-6S (pins need to be gold plated)
Number of teeth on target ring	53
Order number	149055

Connector terminal

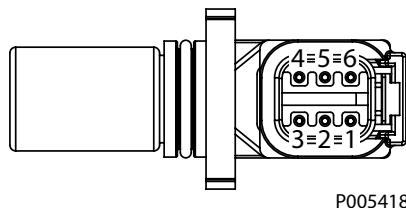

P005418

Sensor pinout:

- 1 – Speed signal 2
- 2 – Direction signal
- 3 – Speed signal 1
- 4 – Supply
- 5 – Ground
- 6 – Temperature

Operation
Bearing life
Bearing life with no external shaft side load

Normal bearing life with no external shaft side load in L_{20} hours is shown in the table below. The figures reflect a continuous delta pressure, shaft speed, maximum displacement, and no external shaft side load. The data is based on a standard charge pressure of 20 bar [290 psi].

Bearing life with no external shaft side load

Parameter	Unit	Size 070	Size 089
Shaft speed	min^{-1} (rpm)	1800	1800
Delta pressure – Δp	bar [psi]	240 [3480]	240 [3480]
Bearing life – L_{20}	hours	68 900	28 500

Conversion of bearing life for other pressure (p) and speed (n):

$$\text{Size 070 } L_{20} = 68\,900 \cdot \left(\frac{240}{p}\right)^{10/3} \cdot \left(\frac{1800}{n}\right)$$

$$\text{Size 089 } L_{20} = 28\,500 \cdot \left(\frac{240}{p}\right)^{10/3} \cdot \left(\frac{1800}{n}\right)$$

External radial shaft loads

TM pumps are designed with bearings that can accept some external radial and axial loads.

The external radial shaft load limits are a function of the load position and orientation, and the operating conditions of the unit.

The maximum allowable radial load (R_e) is based on the maximum external moment (M_e) and the distance (L) from the mounting flange to the load. In applications with external radial shaft loads, minimize the impact by positioning the load at 0° or 180° as shown in the figure below.

The external radial and axial shaft load are limited by the bearing life $L_{20} = 10\,000$ [h], delta system pressure 240 bar, speed 1800 min^{-1} and external radial load at 270° .

It may be determined using the following table and formula below.

Maximum external shaft load based on shaft deflection

Parameter	Unit	Size 089	
External radial moment – M_e	N•m [lbf•in]	0	70 [620]
External axial force – F_{in}	N [lbf]	-2160 [-485]	-1320 [-297]
External axial force – F_{out}		3660 [823]	2880 [648]

Operation

Radial load position

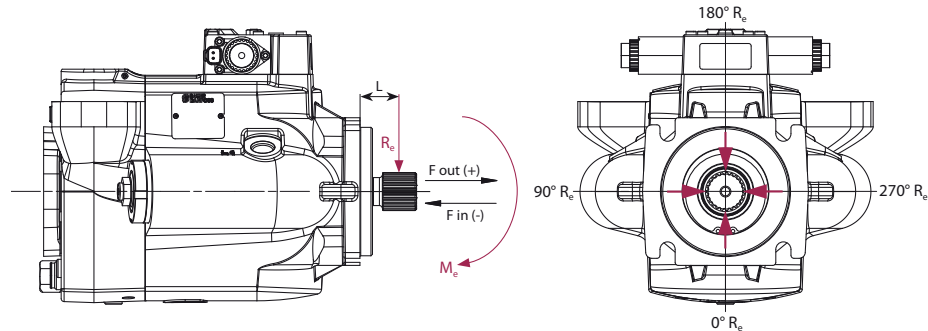

$$R_e = \frac{M_e}{L}$$

Where:

R_e = External force to the shaft

M_e = Shaft moment

L = Flange distance

Contact your Danfoss representative for an evaluation of unit bearing life.

Mounting flange loads

Estimating overhung load moments

Mounting flange load moment

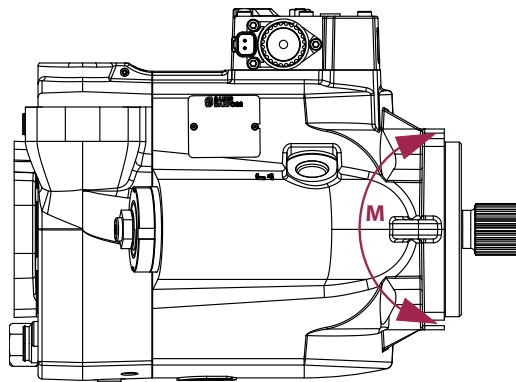

Rated and maximum torque ratings

Based on SI units:

$$M = g \cdot G \cdot W \cdot L$$

$$M = 9.81 \cdot 30 \cdot 61 \cdot 0.1625$$

$$\text{Max. load moment: } M = 2917 \text{ N}\cdot\text{m}$$

Based on US units:

$$M = G \cdot W \cdot L$$

$$M = 30 \cdot 134 \cdot 6.398$$

$$\text{Max. load moment: } M = 25\,818 \text{ lbf}\cdot\text{in}$$

Where:

M = Rated load moment N·m [lbf·in]

g = Gravity 9.81 m/s²

G = Calculation factor for max. acceleration 30

Operation

W = Weight of pump kg [lb]

L = Distance from mounting flange to pump center of gravity m [in]

Input shafts

Rated and maximum torque ratings for each available shaft is shown in the following table:

Specifications

Spline	Min active spline length		Rated torque*		Maximum torque**	
	mm	[in]	N·m	[lbf·in]	N·m	[lbf·in]
21 teeth, 16/32 pitch	33	[1.3]	730	[6460]	1200	[10 620]
23 teeth, 16/32 pitch	33	[1.3]	880	[7790]	1600	[14 160]
Cardan / flange	-	-	-	-	2480	[21 950]

* Rated torque - measure of teeth wear
 ** Maximum torque - ratings are based on torsional fatigue strength

The specified torque rating of the shaft documented above is based on the cross-sectional diameter of the shaft, through the keyway, and assumes the proper clamp and fit between shaft and coupling. Danfoss guarantees the design and manufactured quality of the splined shaft. The customer is responsible for the design and manufactured quality of the mating female coupling and key and applied torque on the nut.

Danfoss has made provisions for the key in accordance to the ISO specification with the understanding that the key is solely to assist in the installation of the mating coupling.

! Caution

Torque or loading inadvertently transmitted by the customer supplied key may lead to premature shaft failure.

ISO 3019-1 (SAE C, 23-teeth)

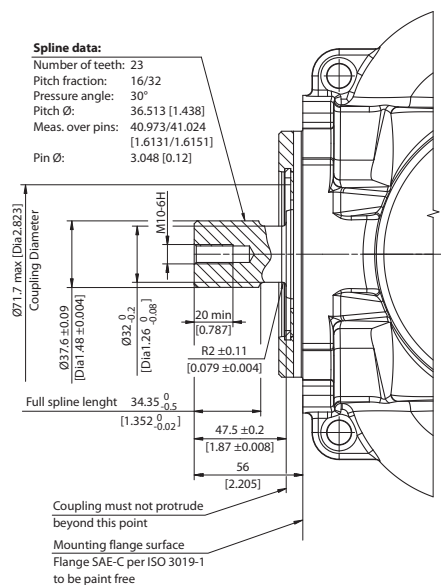

ISO 3019-1 (SAE C, 21-teeth)

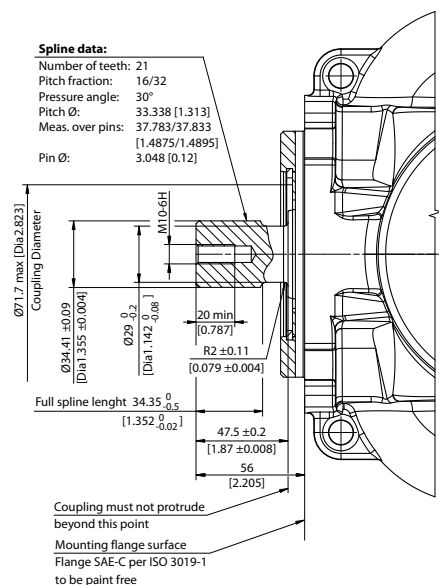

Operation

ISO 3019 (SAE J744C) with coupling

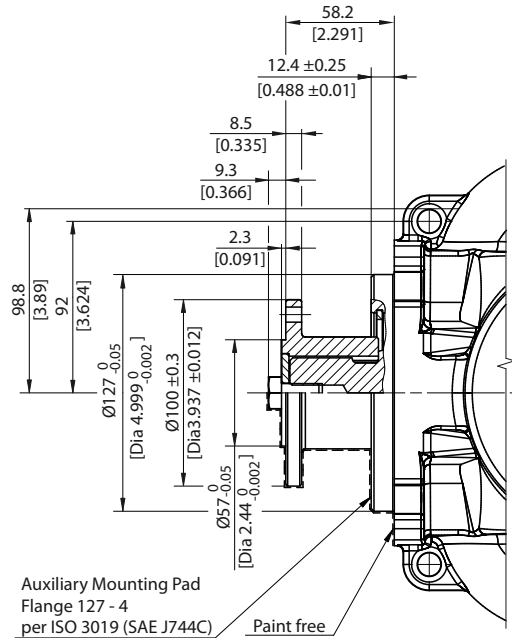

Auxiliary mounting pads

ISO 3019-1, flange 82-2 (SAE A, 9-teeth)

Spline: 9-teeth, 16/32 pitch, Maximum torque: 162 N·m [1430 lbf·in]

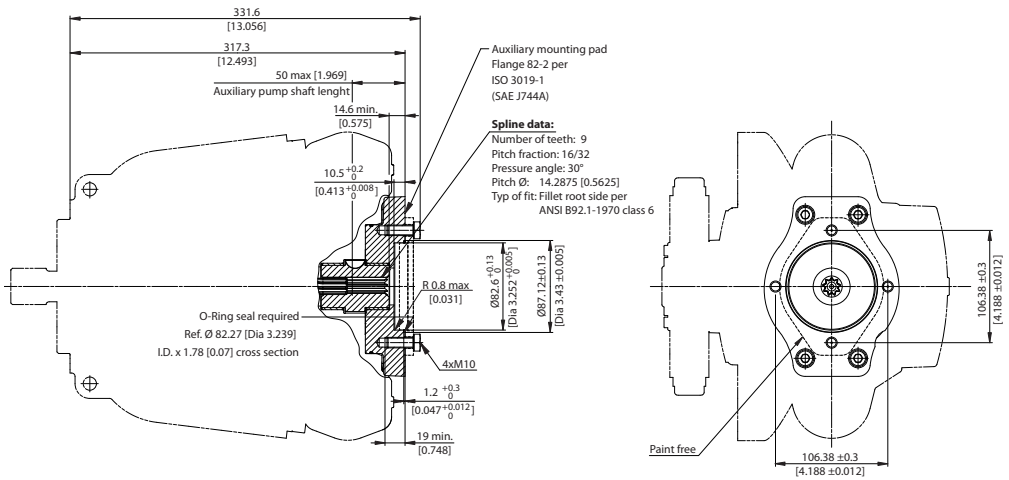

Operation

ISO 3019-1, flange 101-2 (SAE B, 13-teeth)

Spline: 13-teeth, 16/32 pitch, Maximum torque: 395 N·m [3500 lbf·in]

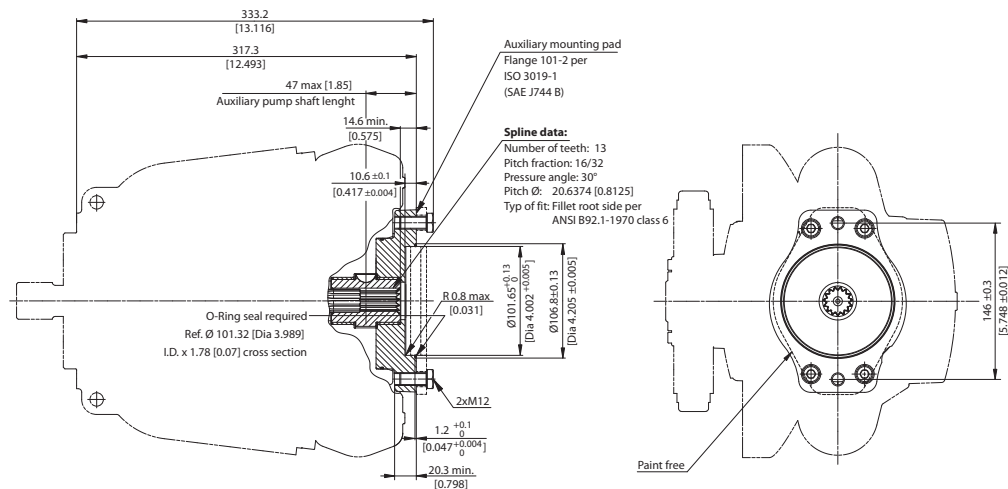

Caution

Standard pad cover is installed only to retain coupling during shipping. Do not operate pump without an auxiliary pump or running cover installed.

ISO 3019-1, flange 101-2 (SAE B-B, 15-teeth)

Spline: 15-teeth, 16/32 pitch, Maximum torque: 693 N·m [6130 lbf·in]

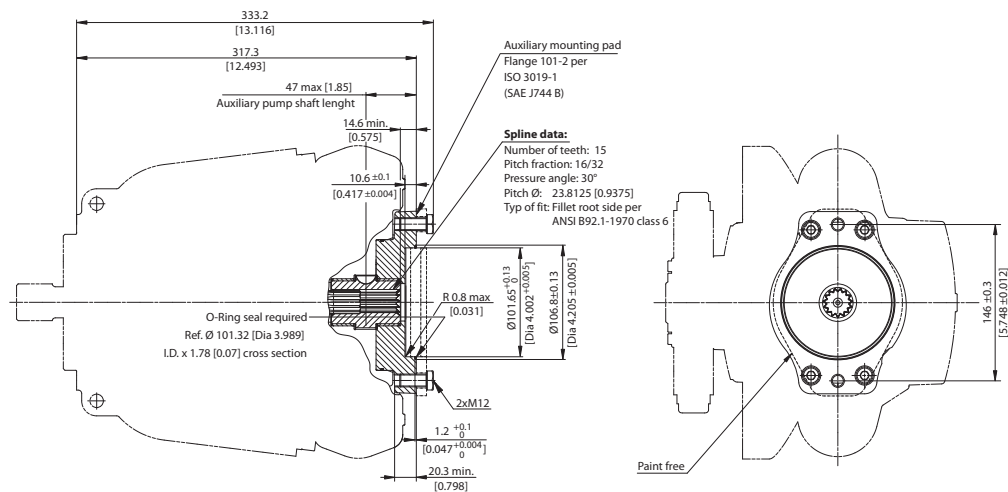

Caution

Standard pad cover is installed only to retain coupling during shipping. Do not operate pump without an auxiliary pump or running cover installed.

Installation drawings

TMP EDC dimensions

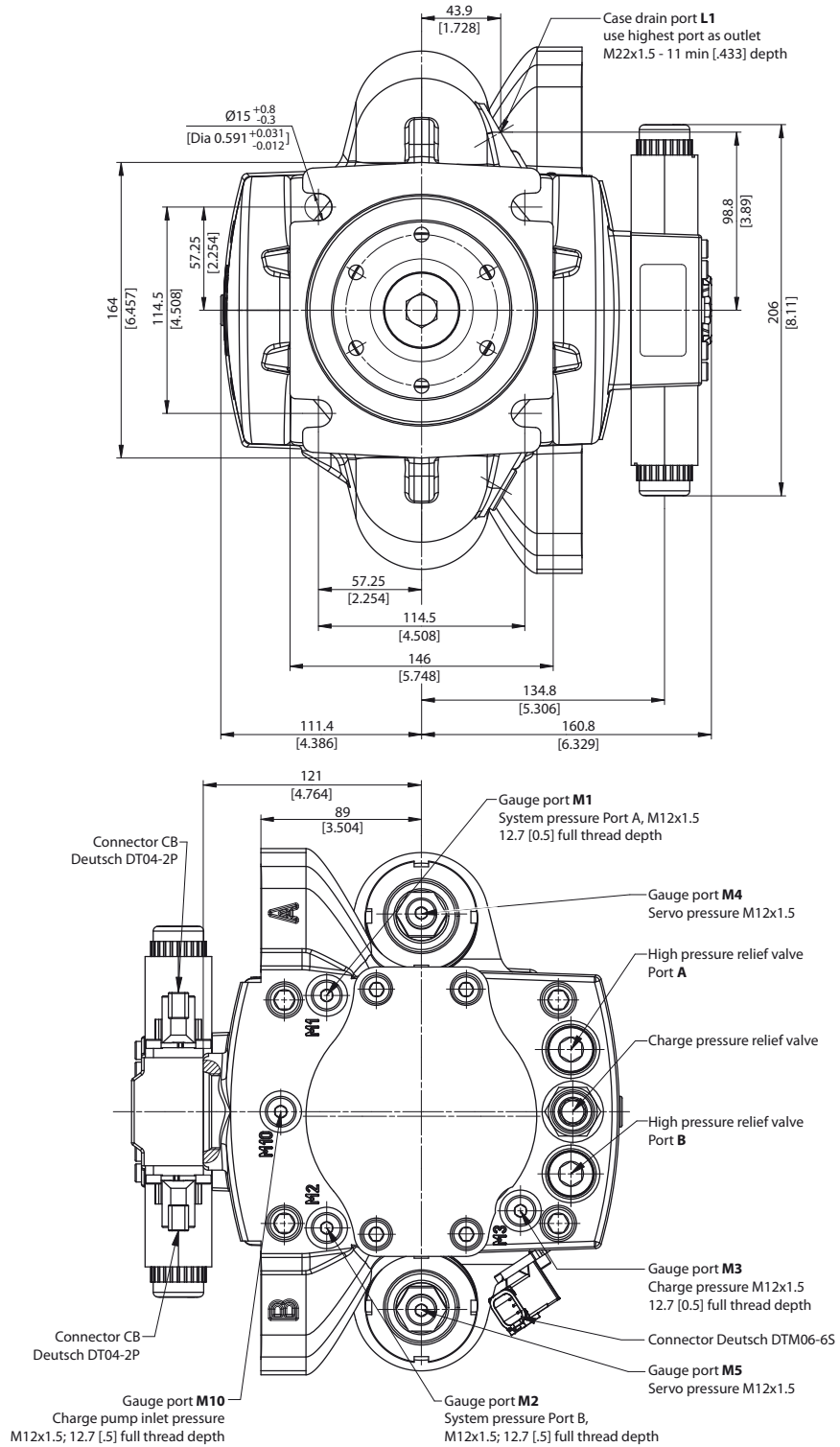

Legend:

M3 – Charge gage port, after filtering: M12x1.5

Installation drawings

- A, B** – System ports: Ø 25.4 mm
- L1, L2** – Case drain ports: M22x1.5
- M1, M2** – System A/B gage ports: M12x1.5
- M4, M5** – Servo gage ports: M12x1.5
- M10** – Charge pump inlet pressure port: M12x1.5
- S** – Charge inlet port: M42x2

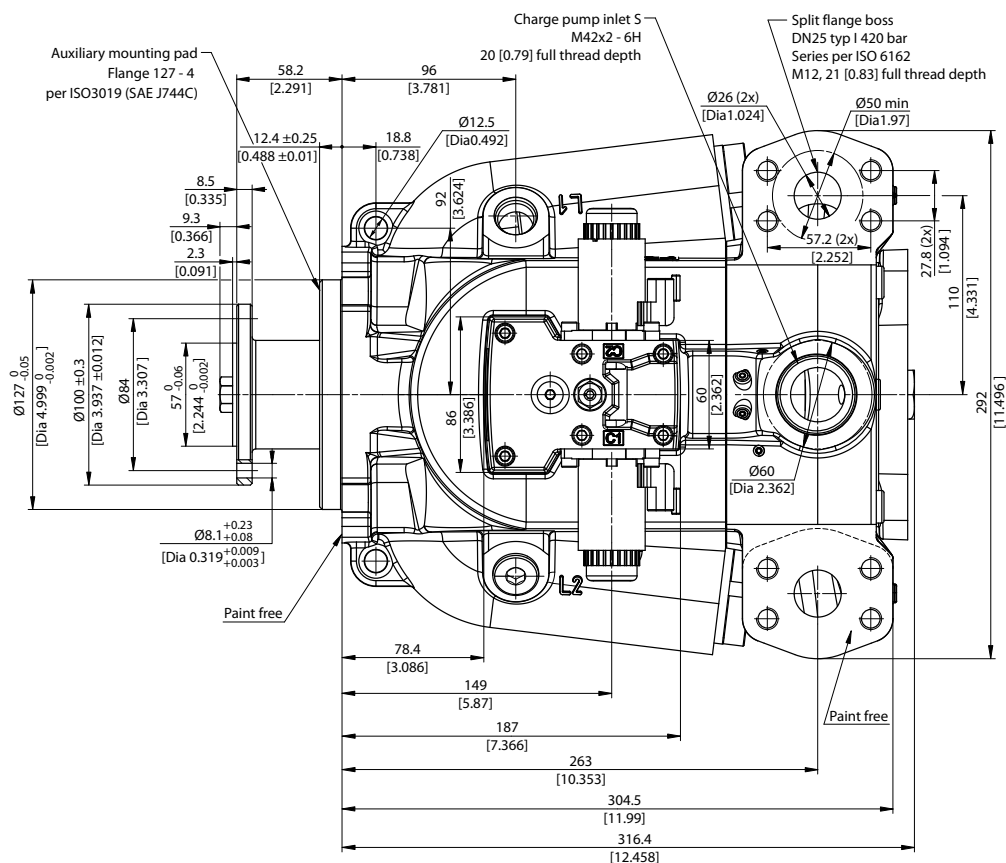

Please contact Danfoss for specific installation drawings.

Installation drawings

EDC dimensions

Electric Displacement Control (EDC) with manual override, options 12 V and 24 V

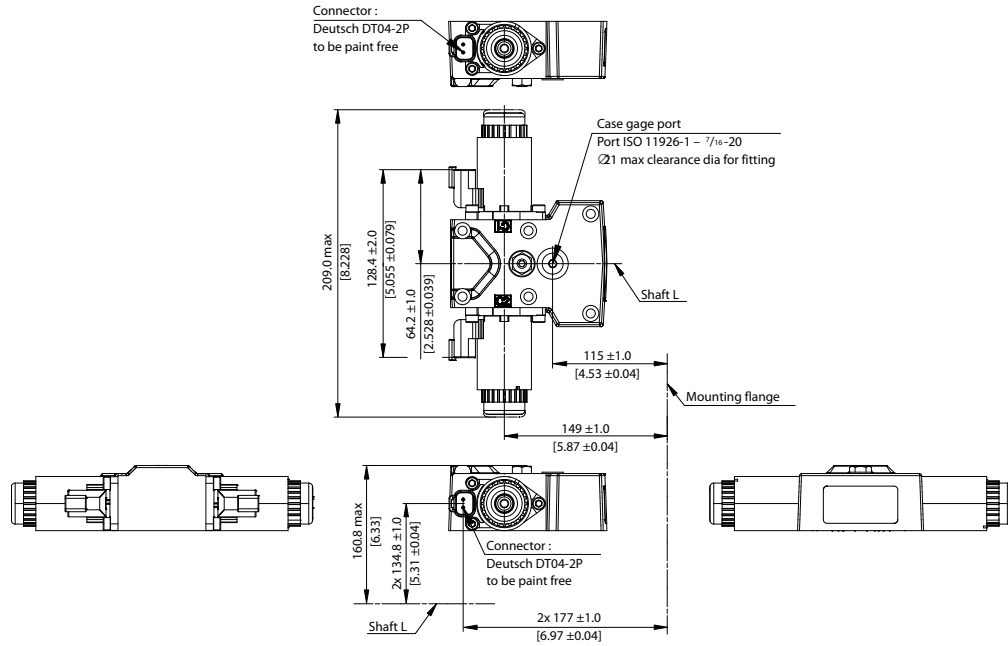

Installation drawings

TMP MDC dimensions

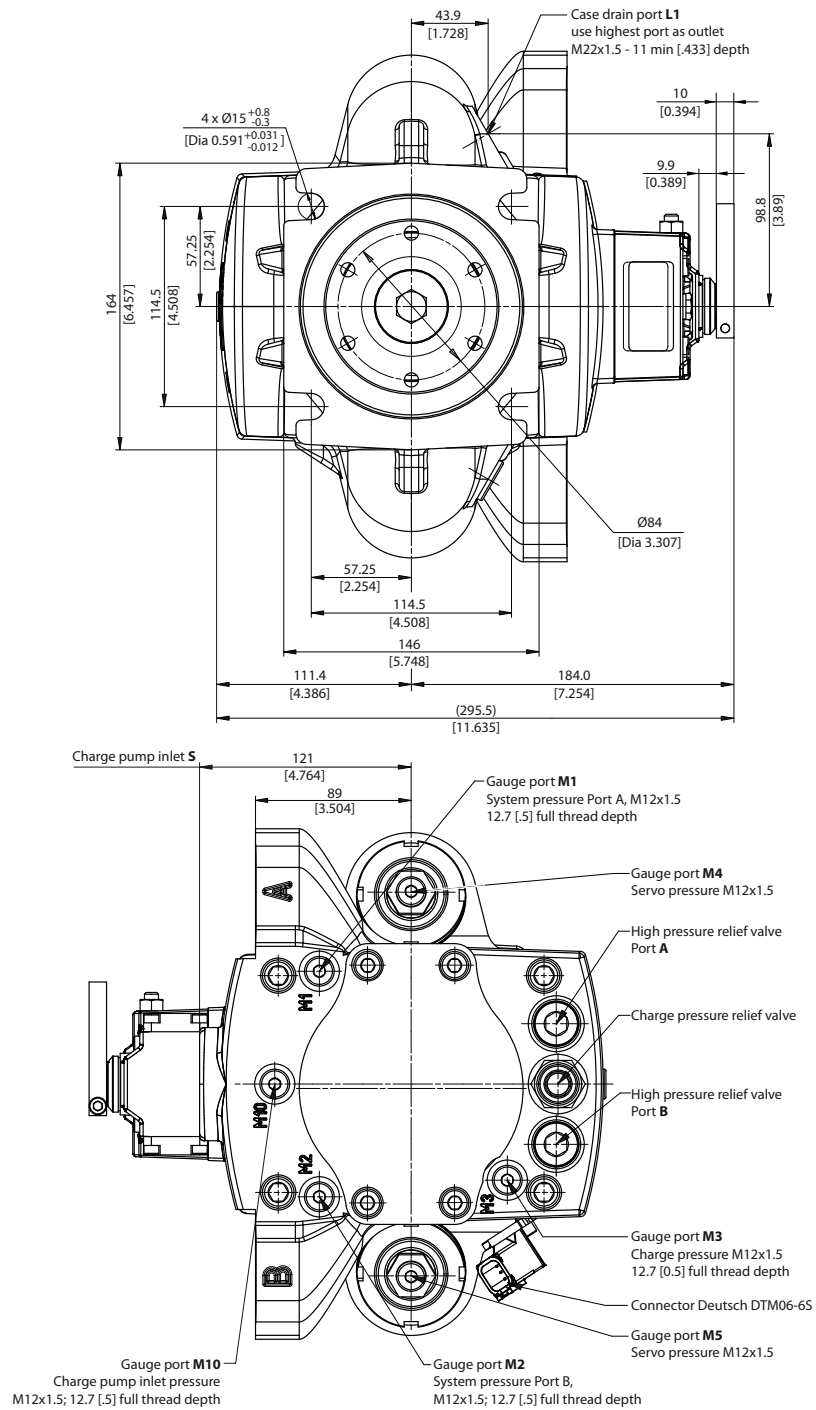

Legend:

A, B – System ports: Ø 25.4 mm

L1, L2 – Case drain ports: M22x1.5

M3 – Charge gage port, after filtering: M12x1.5

M4, M5 – Servo gage ports: M12x1.5

M10 – Charge pump inlet pressure port: M12x1.5

Installation drawings

M1, M2 – System A/B gage ports: M12x1.5

S – Charge inlet port: M42x2

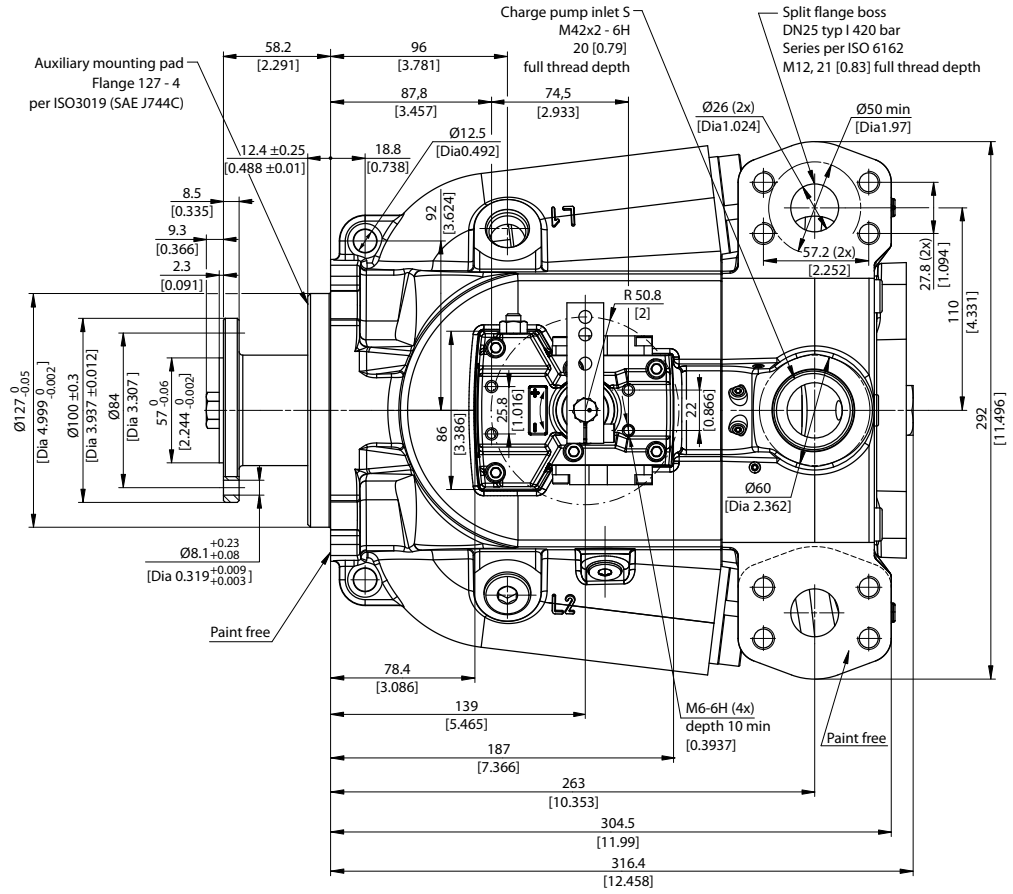

Please contact Danfoss for specific installation drawings.

Installation drawings

MDC dimensions

Manual Displacement Control (MDC)

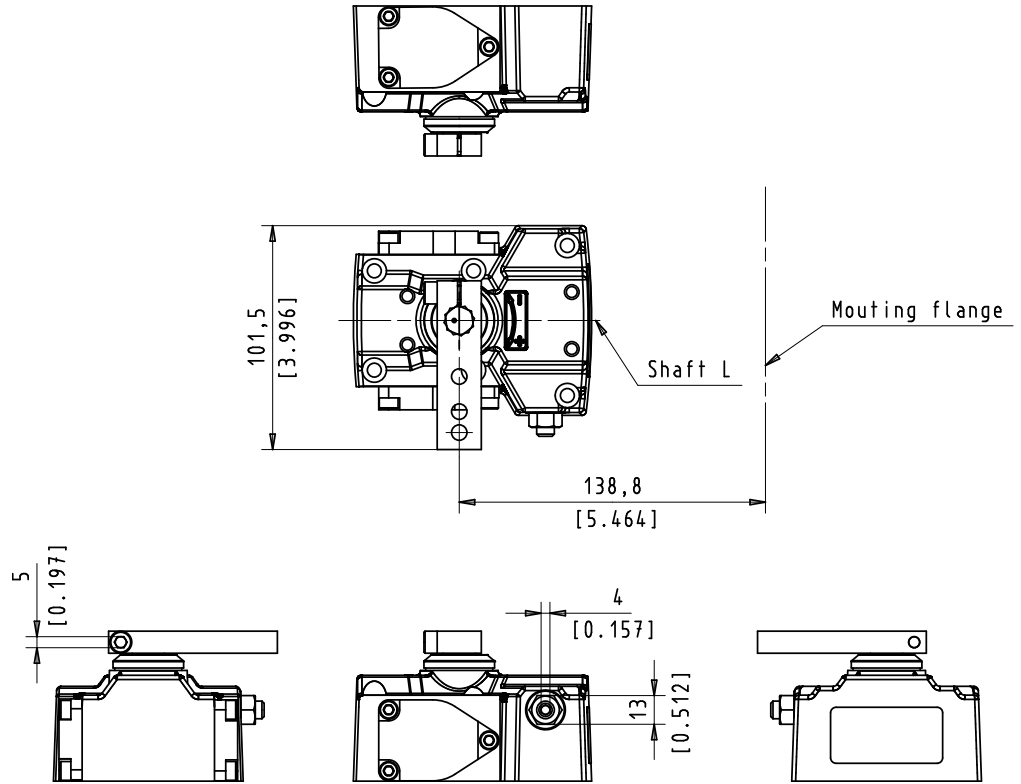

Manual Displacement Control Handle

Manual Displacement Control Handle

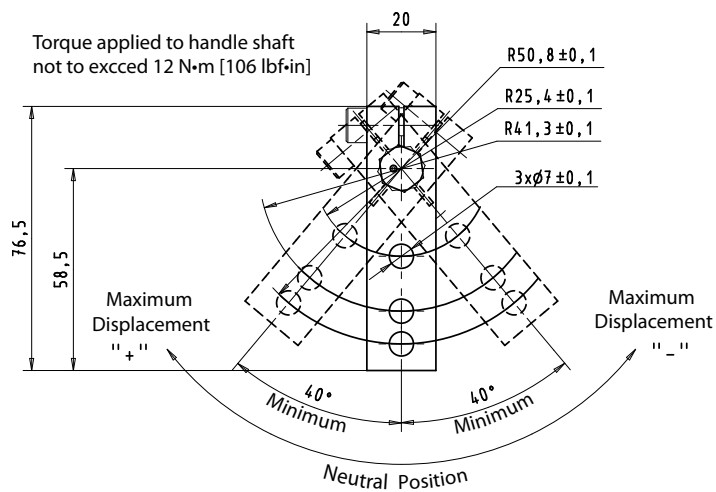

Installation drawings

TMP MDC with Control Cut-Off (CCO) dimensions

Manual Displacement Control (MDC) with CCO, 24 V and Manual Override

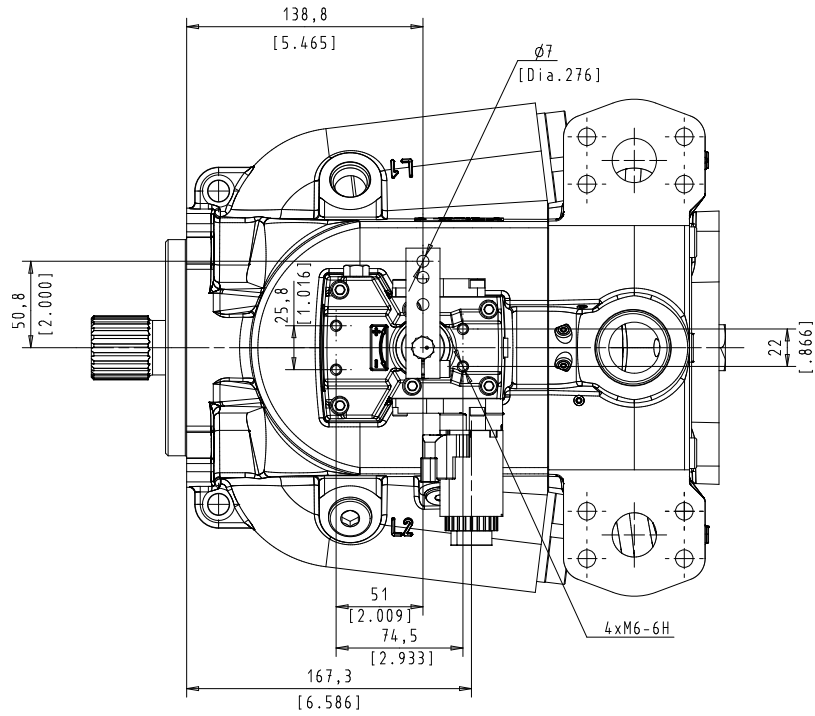

Installation drawings

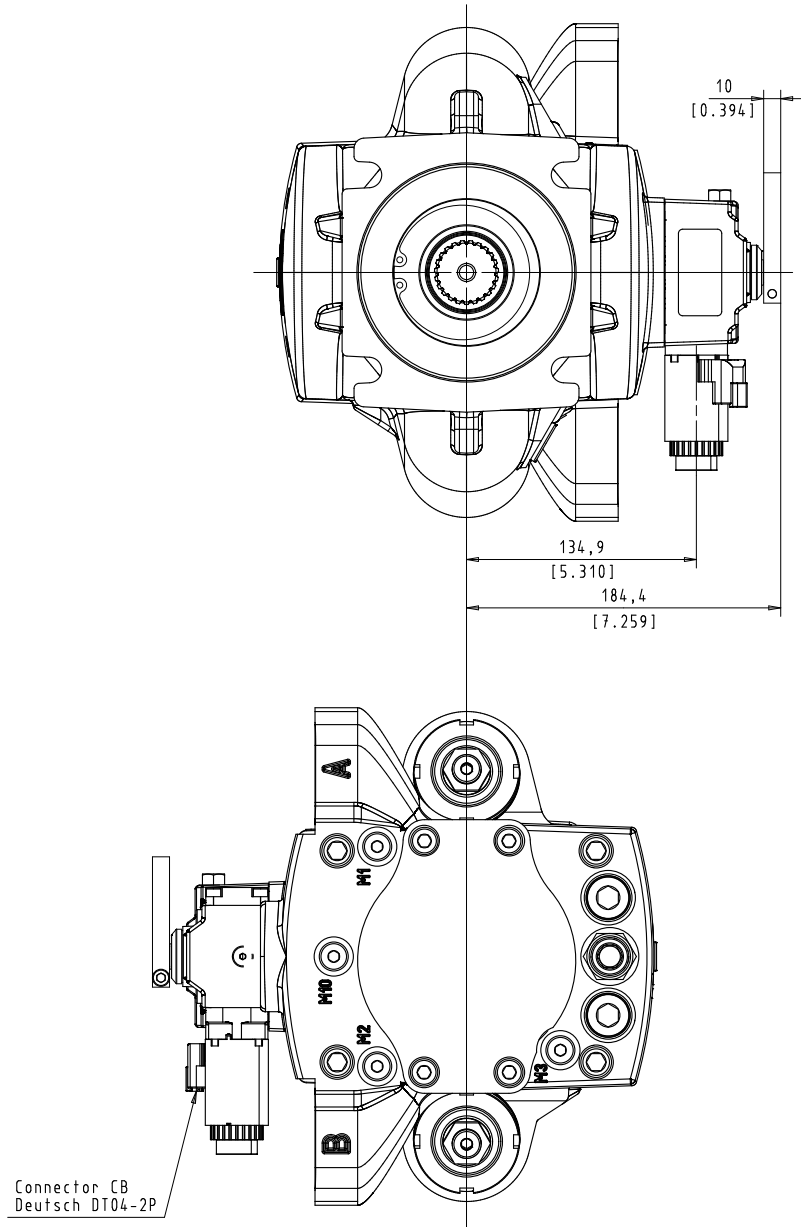

Connector CB
Deutsch DT04-2P

Installation drawings

Manual displacement control with CCO, 24 V and manual override

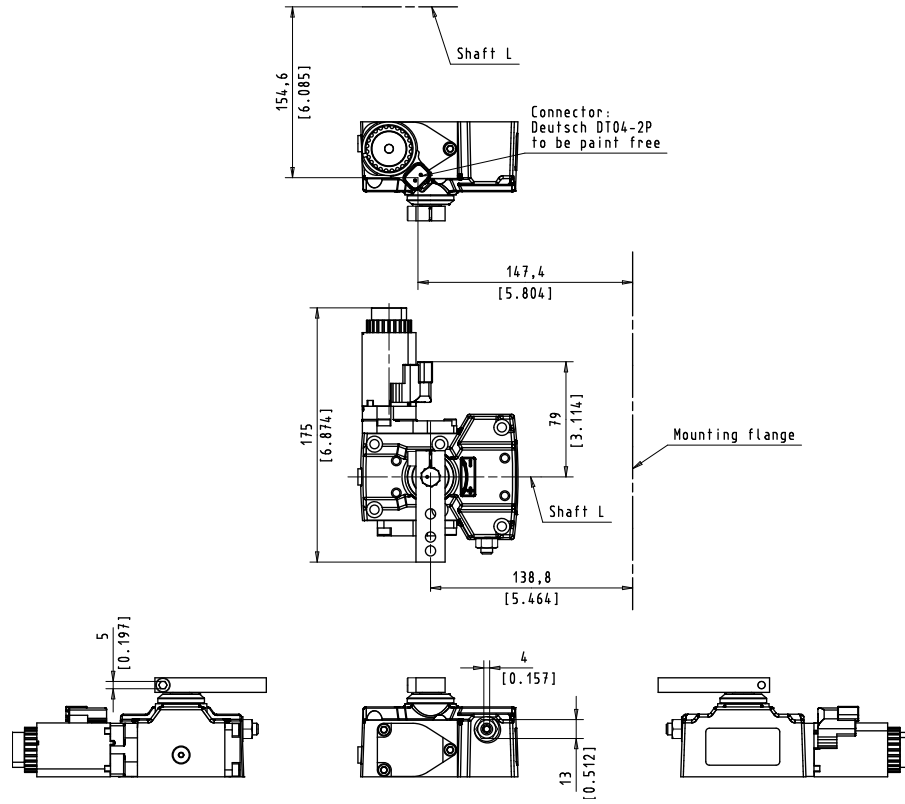



Products we offer:

- Bent Axis Motors
- Closed Circuit Axial Piston Pumps and Motors
- Displays
- Electrohydraulic Power Steering
- Electrohydraulics
- Hydraulic Power Steering
- Integrated Systems
- Joysticks and Control Handles
- Microcontrollers and Software
- Open Circuit Axial Piston Pumps
- Orbital Motors
- PLUS+1® GUIDE
- Proportional Valves
- Sensors
- Steering
- Transit Mixer Drives

Danfoss Power Solutions is a global manufacturer and supplier of high-quality hydraulic and electronic components. We specialize in providing state-of-the-art technology and solutions that excel in the harsh operating conditions of the mobile off-highway market. Building on our extensive applications expertise, we work closely with our customers to ensure exceptional performance for a broad range of off-highway vehicles.

We help OEMs around the world speed up system development, reduce costs and bring vehicles to market faster.

Danfoss – Your Strongest Partner in Mobile Hydraulics.

Go to www.powersolutions.danfoss.com for further product information.

Wherever off-highway vehicles are at work, so is Danfoss.

We offer expert worldwide support for our customers, ensuring the best possible solutions for outstanding performance. And with an extensive network of Global Service Partners, we also provide comprehensive global service for all of our components.

Please contact the Danfoss Power Solution representative nearest you.

Comatrol

www.comatrol.com

Schwarz Müller-Inverter

www.schwarzmueller-inverter.com

Turolla

www.turollaocg.com

Valmova

www.valmova.com

Hydro-Gear

www.hydro-gear.com

Daikin-Sauer-Danfoss

www.daikin-sauer-danfoss.com

Local address:

Danfoss Power Solutions US Company
2800 East 13th Street
Ames, IA 50010, USA
Phone: +1 515 239 6000

Danfoss Power Solutions GmbH & Co. OHG
Krokamp 35
D-24539 Neumünster, Germany
Phone: +49 4321 871 0

Danfoss Power Solutions ApS
Nordborgvej 81
DK-6430 Nordborg, Denmark
Phone: +45 7488 2222

Danfoss Power Solutions (Shanghai) Co. Ltd.
Building #22, No. 1000 Jin Hai Rd
Jin Qiao, Pudong New District
Shanghai, China 201206
Phone: +86 21 3418 5200

Danfoss can accept no responsibility for possible errors in catalogues, brochures and other printed material. Danfoss reserves the right to alter its products without notice. This also applies to products already on order provided that such alterations can be made without subsequential changes being necessary in specifications already agreed. All trademarks in this material are property of the respective companies. Danfoss and the Danfoss logotype are trademarks of Danfoss A/S. All rights reserved.