

ENGINEERING
TOMORROW



Service Manual

Cartridge Mount Reverse Displacement Motors (RDM)



Revision history*Table of revisions*

Date	Changed	Rev
May 2016	new housing	0104
February 2015	update Port locations and gauge installation	AC
November 2014	add K Frame	AB
May 2014	First edition - Danfoss layout	AA

Contents**General Information**

Overview.....	4
Safety precautions.....	4
Symbols used in Danfoss literature.....	5
Basic Design.....	5
Key Features.....	6
Schematic Diagrams.....	7

Technical Specifications

Overview.....	8
Features and Options.....	8
Specifications.....	8
Operating Parameters.....	8
Electrical Parameters.....	9
Fluid Specifications.....	9

Features

Output shafts.....	10
Controls.....	10

Pressure measurements

Required tools.....	12
Port locations and gauge installation.....	12

Initial start-up procedures

General	13
Startup-procedure.....	13

Fluid and filter maintenance

Recommendations.....	14
----------------------	----

Troubleshooting

Excessive noise and/or vibration.....	15
System operating hot.....	15
Motor shifting irregularities.....	15

Minor repair

Shaft seal replacement.....	16
Remove the shaft seal.....	16
Inspect the components.....	16
Install the new shaft seal.....	16
Shifting Valve.....	17
Remove shifting valve.....	17
Inspect the components.....	17
Install shifting valve.....	17
Anti-Cavitation Valve.....	17
Remove the anti-cavitation valve.....	17
Inspect the components.....	18
Install the anti-cavitation valve.....	18
Speed Sensor installation and adjustment.....	18

General Information

Overview

This manual includes information for the installation, maintenance, and minor repair of the Reverse Displacement Motors (RDM). The manual includes a description of the units and their individual components, troubleshooting information, and minor repair procedures. Performing installation, maintenance, and minor repair of RDM Motors according to the procedures in this manual will not affect your warranty.

Performing minor repairs requires the unit to be removed from the vehicle/machine. Thoroughly clean the unit before beginning maintenance, or repair activities. Since dirt and contamination are the greatest enemies of any type of hydraulic equipment, follow cleanliness requirements strictly. This is especially important when changing the system filter and when removing hoses or plumbing.

A worldwide network of Danfoss Authorized Service Centers (ASCs) is available for major repairs. Major repairs require the removal of the unit's endcap, which voids the warranty unless done by an ASC. Danfoss ASCs are trained by the factory and certified on a regular basis. You can locate your nearest ASC using the distributor locator at www.powersolutions.danfoss.com.

Safety precautions

Always consider safety precautions before beginning a service procedure. Protect yourself and others from injury. Take the following general precautions whenever servicing a hydraulic system.

Warning

Unintended vehicle or machine movement hazard

When using the RDM in combination with S45 open circuit pumps with LS or EPC be aware that there will likely be motor movement as long as the engine is turning. Due to the LS-setting of the pump, a standby pressure will remain in the system even if the normally closed control is fully energized. Lowest standby pressures to the motor, 15-18bar or above, may be enough to turn the RDM and has the potential to cause injury or damage.

Warning

Flammable cleaning solvents

Some cleaning solvents are flammable. To eliminate the risk of fire, do not use cleaning solvents in an area where a source of ignition may be present.

Warning

Fluid under pressure

Escaping hydraulic fluid under pressure can have sufficient force to penetrate your skin causing serious injury and/or infection. This fluid may also be hot enough to cause burns. Use caution when dealing with hydraulic fluid under pressure. Relieve pressure in the system before removing hoses, fittings, gauges, or components. Never use your hand or any other body part to check for leaks in a pressurized line. Seek medical attention immediately if you are cut by hydraulic fluid.

Warning

Personal safety

Protect yourself from injury. Use proper safety equipment, including safety glasses, at all times.

General Information

Symbols used in Danfoss literature

	WARNING may result in injury		Tip, helpful suggestion
	CAUTION may result in damage to product or property		Lubricate with hydraulic fluid
	Reusable part		Apply grease / petroleum jelly
	Non-reusable part, use a new part		Apply locking compound
	Non-removable item		Inspect for wear or damage
	Option - either part may exist		Clean area or part
	Superseded - parts are not interchangeable		Be careful not to scratch or damage
	Measurement required		Note correct orientation
	Flatness specification		Mark orientation for reinstallation
	Parallelism specification		Torque specification
	External hex head		Press in - press fit
	Internal hex head		Pull out with tool – press fit
	Torx head		Cover splines with installation sleeve
	O-ring boss port		Pressure measurement/gauge location or specification

The symbols above appear in the illustrations and text of this manual. They are intended to communicate helpful information at the point where it is most useful to the reader. In most instances, the appearance of the symbol itself denotes its meaning. The legend above defines each symbol and explains its purpose.

Basic Design

The Reverse Displacement Motors (RDM) are medium power two-position axial piston motors incorporating an integral servo piston. They are especially designed for operation in open circuit, non propel applications. With the ability to shift over center, this motor combines reversing functionality and the simplicity of open circuit design without the need for additional, external valves (HIC's). For fan drive system design guidelines refer to Danfoss publication: *Hydraulic Fan Drive Systems - Design Guidelines, 520L0926*

The RDM uses the existing and proven technology of the Danfoss L/K motor. These motors have been optimized with regard to options, life, package size and installed cost. The RDM consists of five unique rotating groups (displacements) in two housings with cartridge mounting flanges. Maximum speeds and maximum applied pressures for each displacement vary. The standard control is an integrated shift valve that uses system pressure. The integral servo piston controls motor displacement. The motor is spring biased to forward displacement and hydraulically shifted to reverse displacement.

Displacement for both directions is set with fixed internal stops. The integrated shifting valve in combination with large diameter servo piston allows smooth shifting between forward and reverse rotation. For system protection the motors are equipped with an integrated anti-cavitation and shock valve. The motor is ideally configured for installations requiring compact packaging and optimized plumbing with one face of the motor containing all hydraulic porting.

General Information

K Frame Cross Section

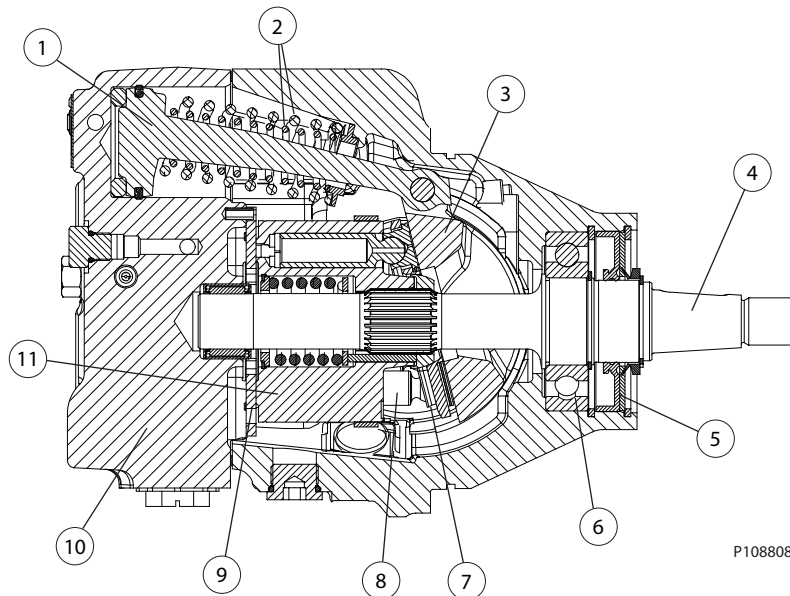

P108808

- | | |
|----------------|-------------------|
| 1 Servo piston | 7 Slipper |
| 2 Bias springs | 8 Piston |
| 3 Swashplate | 9 Valve plate |
| 4 Output shaft | 10 Endcap |
| 5 Shaft seal | 11 Cylinder block |
| 6 Bearing | |

Key Features

Designed For Durability and Flexibility

- Designed for open circuit applications
- Five displacements allow the optimum selection of a hydraulic motor to fit your application
- Uses the existing and proven technology of Danfoss L/K motors, for maximum reliability

Installation and Packaging Benefits

- Short and compact total installed package
- High Efficiency - nine piston rotating groups with a positive and negative 18 degree maximum angle
- Uses system pressure for shifting - no external pressure supply needed
- Integrated shifting valve enables reversing - no external valves needed, which means less hoses, less losses providing a simple and clean installation
- 12Vdc and 24 Vdc shifting valves

Wide Range of Options

- Fail Safe: Without control signal, the motor is biased to maximum forward speed
- Damped shifting
- Shaft options with dust seal protector
- Integrated system protection - anti-cavitation and shock valve
- High capacity bearings to withstand axial fan forces
- Complimentary to Danfoss Series 45 open circuit pumps with electronic proportional control
- PLUS+1 micro controller with fan drive software available
- Variety of porting options allow for easier system configurations

General Information

- Metric O-Ring boss
- SAE O-Ring boss
- Split flange
- A speed sensor is available

Schematic Diagrams

Pressure port A (CW rotation)

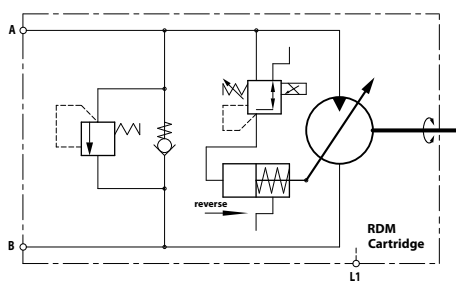

Pressure port B (CCW rotation)

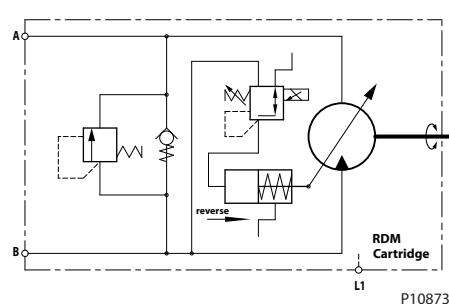

P108731

Technical Specifications

Overview

Specifications and operating parameters for RDM motors are given here for quick reference. For additional information, see *Operating Parameters, Features and Options*, and *Product Coding*.

Features and Options

Mount	Cartridge
Motor type	Inline, axial piston, open circuit, reverse displacement motors
Displacement	L: 25, 30, or 35 cm ³ [1.50, 1.83, or 2.14 in ³] K: 38 or 45 cm ³ [2.32, or 2.75 in ³]
Rotation	Bidirectional
Installation position	Discretionary: Housing must always be filled with hydraulic fluid
Porting	Split flange - SAE O-ring boss, Metric O-ring boss
Output shafts	Tapered, 0.875 in Dia, 1.5 in/ft taper; Straight key, 0.875 in Dia, with dust seal
Control options	Integrated shift valve, 12Vdc/24Vdc
Displacement limiter	Fixed maximum and minimum displacement limiters available
Dust seal	Standard - refer to <i>Features and Options</i> in the RDM Technical Information manual.
High capacity bearing	Standard - more options available
Speed sensor	Available - refer to <i>Features and Options</i> in the RDM Technical Information manual.
Anti-Cavitation-Valve	Standard - refer to <i>Features and Options</i> in the RDM Technical Information manual.

Specifications

Parameter	Unit	LM25	LM30	LM35	KM38	KM45
Displacement (maximum)	cm ³ [in ³]	25 [1.50]	30 [1.83]	35 [2.14]	38 [2.32]	45 [2.75]
Weight (cartridge and SAE-B)	kg [lb]	17.5 [38.6]				
Mass moment of inertia of rotating components	kg·m ² [slug·ft ²]	0.0017 [0.0012]	0.0016 [0.0012]	0.0015 [0.0011]	0.0023 [0.0017]	0.0023 [0.0017]
Theoretical torque	N·m/bar [lbf·in/1000psi]	0.40 [244]	0.48 [293]	0.56 [347]	0.60 [366]	0.72 [439]

Operating Parameters

Parameter		Unit	LM25	LM30	LM35	KM38	KM45
System pressure	rated/continuous	bar [psi]	260 [3770]	260 [3770]	260 [3770]	260 [3770]	260 [3770]
	maximum		350 [5075]	350 [5075]	325 [4715]	350 [5075]	325 [4715]
Output speed (at max. disp.)	rated	min ⁻¹ (rpm)	3400	3500	3600	3600	3500
	maximum		3950	4150	4300	4000	3900
Case pressure limits	Rated	bar [psi]	0.5 [7] above outlet pressure, 2 [29] maximum pressure				
	Maximum		2 [29] above outlet pressure, 6 [87] maximum pressure				

Technical Specifications

Electrical Parameters

Parameter		Unit	Value
Voltage		Vdc	12, 24
Maximum current recommended (PWM)	12 Vdc	mA	1500
	24 Vdc		750
Connector		-	Deutsch Connector DT04-2P

Fluid Specifications

Parameter	Unit	Minimum	Continuous	Maximum
Viscosity	mm ² /sec (cSt) [SUS]	7 [47]	12-60 [70-278]	1600 [7500]
Temperature	°C [°F]	-40 [-40]	82 [180]	104 [220]
Cleanliness		ISO 4406 Class 18/13 or better		
Filtration efficiency	suction filtration	$\beta_{35-44}=75$ ($\beta_{10} \geq 1.5$)		

Ratings and data are based on operation with premium petroleum-based hydraulic fluids containing oxidation, rust, and foam inhibitors.

Features

Output shafts

RDM motors may have 22,23mm [0.875 in] 1:8 tapered or straight keyed shafts. Both options have a Dust Seal. For dimensions, refer to *RDM Variable Motors Technical Information, L1424445*.

Controls

Reverse Displacement Motors are designed to operate in two positions: maximum forward and maximum reverse displacement. The motors are spring biased to maximum forward displacement and hydraulically shifted to reverse.

Reverse Displacement Motors have an integrated shifting valve to go from forward to reverse rotation.

The shifting valve is a proportional pressure reducing valve using system pressure to pilot the servo piston.

The proportional controllability can be used to achieve a smooth shifting between forward and reverse rotation. The diagram below shows the motor control characteristics related to valve current (12 Volt solenoid).

The shaded portion is indicative of the possible variation in shift characteristics. Variation is caused by differences in system pressure, speed and temperature.

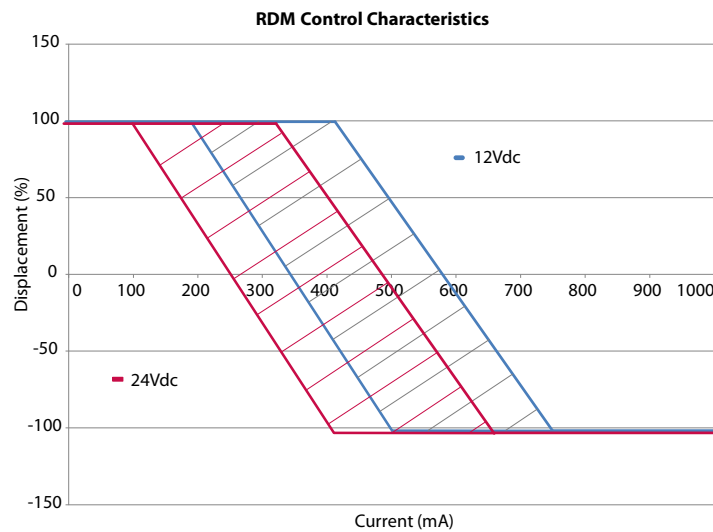

P108736

For information regarding Electrical Specifications see [Electrical Parameters](#).

The RDM control has a failsafe design. The integrated shift valve acts like an orifice to dampen the shifting between maximum forward to maximum reverse and back. This feature protects the system components against fatal damage in case the control signal changes without ramping or if it gets lost immediately while reversing.

Control orifice, port A high pressure; CW rotation (de-energized shift valve)

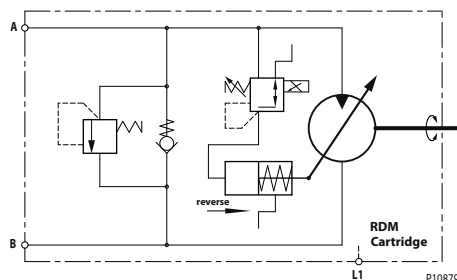

Features

Fail Safe Control Characteristic

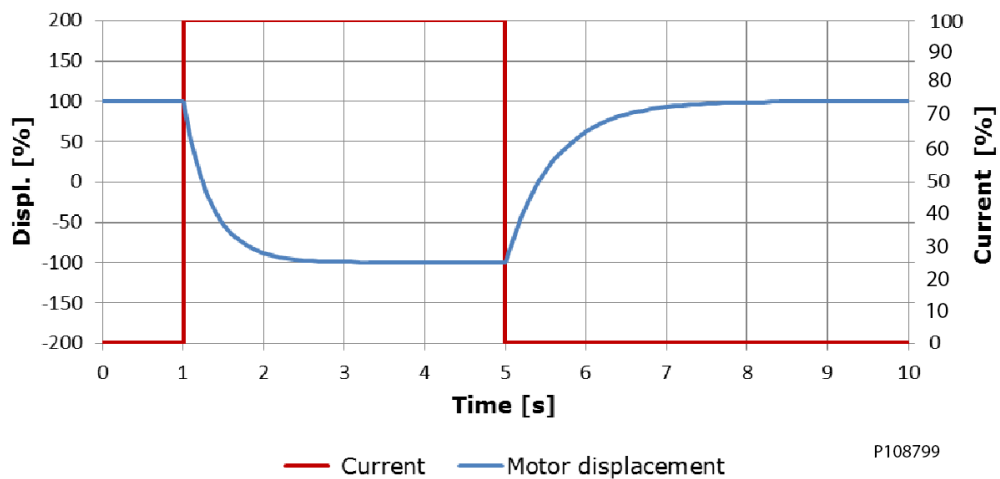

P108799

Control current

Supply Voltage (Vdc)	Current Range 0-100% [mA]
12	0-1500
24	0-750

Pressure measurements

Required tools

The service procedures described in this manual can be performed using common mechanic's hand tools. Special tools, if required are shown. Calibrate pressure gauges frequently to ensure accuracy. Use snubbers to protect gauges.

Port locations and gauge installation

Pressure measurements can be obtained by installing tee fittings to the connections at the locations listed in the table below. Recommended gauge sizes are listed.

Twin radial port locations

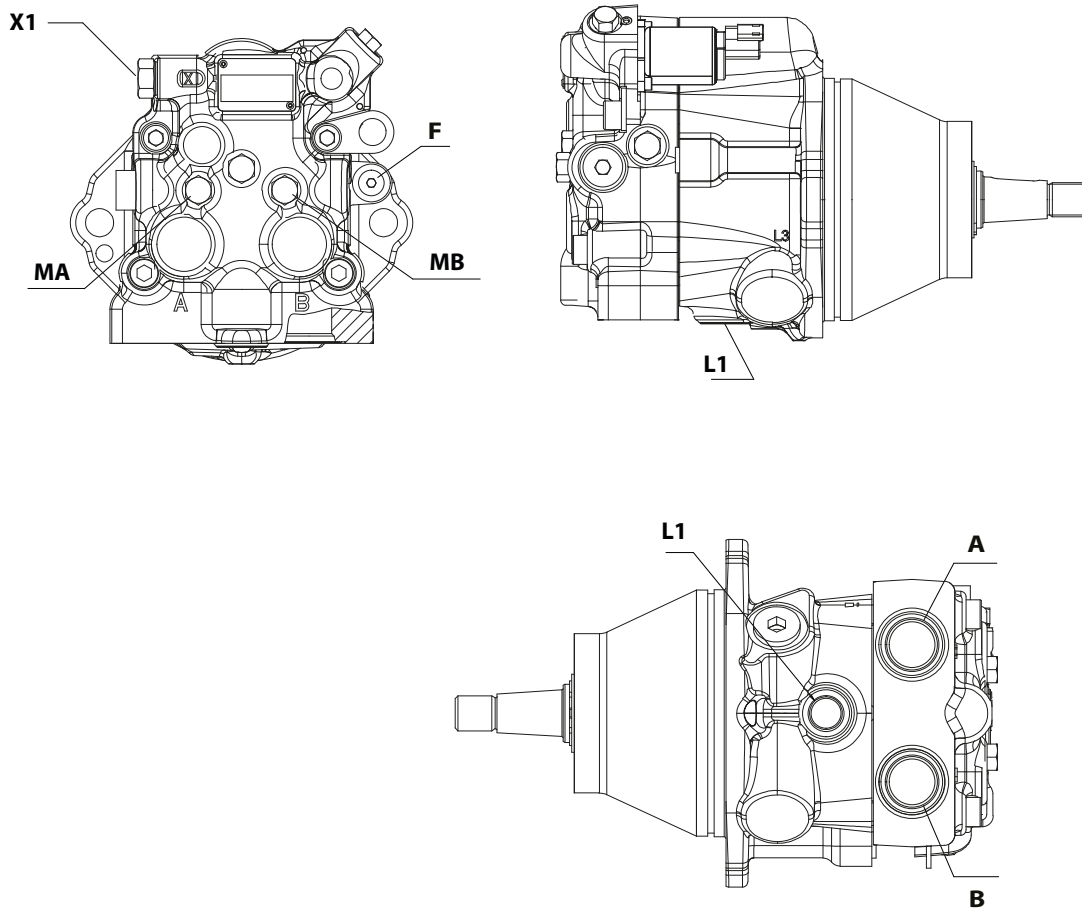

P108844

Port information

Port identifier	Metric	Inch	Pressure obtained	Gauge size, bar [psi]
X1	ISO 6941-1, M 18x1.5	ISO 11926-1, 3/4-16	Control signal	600 [10 000]
L1	ISO 6941-1, M 14x1.5	ISO 11926-1, 9/16-18	Case drain	10 [100]
A/B	ISO 6941-1, M 27x2	ISO 11926-1, 1-1/16-12	System pressure	600 [10 000]
MA/MB	ISO 11926-1, 7/16 - 20		System gauge port	600 [10,000]
F	ISO 11926-1, 7/16-20		Brake release port	-

Initial start-up procedures

General

Follow this procedure when starting-up a new motor installation or when restarting an installation in which the motor has been removed.

⚠ Warning

Unintended vehicle or machine movement hazard

When using the RDM in combination with S45 open circuit pumps with LS or EPC be aware that there will likely be motor movement as long as the engine is turning. Due to the LS-setting of the pump, a standby pressure will remain in the system even if the normally closed control is fully energized. Lowest standby pressures to the motor, 15-18 bar or above, may be enough to turn the RDM and has the potential to cause injury or damage.

Prior to installing the motor, inspect for damage incurred during shipping. Make certain all system components (reservoir, hoses, valves, fittings, heat exchanger, etc.) are clean prior to filling with fluid.

Startup-procedure

1. Fill the reservoir with recommended hydraulic fluid. Always filter fluid through a 10 micron filter when pouring into the reservoir. Never reuse hydraulic fluid.
2. Fill the inlet line leading from the pump to the reservoir. Check the inlet line for properly tightened fittings and be certain it is free of restrictions and air leaks.
3. Fill the pump and motor housing with clean hydraulic fluid. Pour filtered oil directly into the case drain port.
4. To ensure the pump and motor stay filled with oil, install case drain lines into the case drain port.
5. When using Series 45 pump, install a gauge at port M1 to monitor system pressure during start up. Alternatively use a tee fitting to install a gauge at the high pressure motor port (A or B).

[Follow recommendations in the vehicle / machine operator's manual for prime mover start up procedures.](#)

6. While watching the pressure gauge, jog the prime mover or run at the lowest possible speed until system pressure builds to normal levels (minimum 11 bar [160 psi]). Once system pressure is established, increase to full operating speed. If system pressure is not maintained, shut down the prime mover, determine cause, and take corrective action. Refer to [Troubleshooting](#) on page 15.
 7. Operate the hydraulic system for at least fifteen minutes under light load conditions.
 8. Check and adjust pump control settings as necessary after installation.
 9. Shut down the prime mover and remove the pressure gauge. Replace plug at the gauge port (remove tee fitting).
 10. Check the fluid level in the reservoir; add clean filtered fluid if necessary.
- The motor is now ready for operation.

Fluid and filter maintenance**Recommendations**

To ensure optimum life of these motors, perform regular maintenance of the fluid and filter. Contaminated fluid is the main cause of unit failure. Take care to maintain fluid cleanliness when servicing.

Check the reservoir daily for proper fluid level, the presence of water, and rancid fluid odor. Fluid contaminated by water may appear cloudy or milky or free water may settle in the bottom of the reservoir. Rancid odor indicates the fluid has been exposed to excessive heat. Change the fluid immediately if these conditions occur. Correct the problem immediately.

Change the fluid and filter per the vehicle / machine manufacturer's recommendations or at these intervals:

Fluid and filter change interval

Reservoir type	Max oil change interval
Sealed	2000 hours
Breather	500 hours

Change the fluid more frequently if it becomes contaminated with foreign matter (dirt, water, grease, etc.) or if the fluid is subjected to temperature levels greater than the recommended maximum.

[Dispose of used hydraulic fluid properly. Never reuse hydraulic fluid.](#)

Change filters whenever the fluid is changed or when the filter indicator shows that it is necessary to change the filter. Replace all fluid lost during filter change.

Troubleshooting

Excessive noise and/or vibration

Item	Description	Action
Check oil level in reservoir and oil supply to the motor.	Insufficient hydraulic fluid could lead to cavitation that would cause system noise.	Fill the reservoir to the proper level and ensure that oil supply to the motor is adequate and the lines are unobstructed.
Check for air in the system.	Air trapped within the system lines, or the motor itself, could result in cavitation that would cause system noise.	Ensure that all of the system lines and components are purged of air.
Inspect the output shaft couplings.	A loose or incorrect shaft coupling will produce vibrations that could result in system noise.	Ensure that the correct coupling is used and that it fits properly onto the shaft.
Inspect the output shaft alignment.	Misaligned shafts create excessive frictional vibration that could result in system noise.	Ensure that the shafts are properly aligned.
Hydraulic oil viscosity above limits.	Viscosity above acceptable limits will result in cavitation that would lead to system noise.	Replace hydraulic oil with appropriate fluid for operating conditions. Refer to publication 5200L0463 for information on fluid selection.

System operating hot

Item	Description	Action
Check oil level in reservoir and oil supply to the pump.	Insufficient amount of hydraulic fluid will not meet the cooling demands of the system.	Fill the reservoir to the proper level.
Inspect the heat exchanger, (if so equipped).	If the heat exchanger fails, or becomes obstructed, it may not meet the cooling demands of the system.	Ensure that heat exchanger is receiving adequate air flow and that the heat exchanger is in good operating condition. Repair or replace as necessary.
Check the system relief valves.	If a system relief valve becomes unseated for an extended period of time or fails for any other reason, the system could become overheated.	Repair or replace any malfunctioning relief valves as applicable and verify that the loads on the machine are not excessive.

Motor shifting irregularities

Item	Description	Action
Check the electrical connection and electrical signal to the shifting valve coil.	Electrical signal is needed to energize the valve coil. The energized coil is shifting the motor.	Ensure that the electrical connection between controller valve coil is alright. Check wires and connectors. Check electric signal. Valve coil can be energized with 12V PWM-signal or directly with 12V.
Check valve coil	The energized valve coil is moving the valve spool. That leads to motor shifting.	Measure valve coil resistance. Value needs to be 5,3ohms +-5%. Replace valve if resistance is differing.
Check shifting pressure.	Shifting pressure moves servo piston. Obstruction could result in slow or no shift conditions.	Shifting pressure at full energized valve coil (1500mA) needs to be at 20-32bar [290-464psi] or system input pressure, whichever is lower. Replace shifting valve when measured pressure is differing.

Minor repair

Shaft seal replacement

Remove the shaft seal

1. Remove the snap ring (D007).
2. Remove dust seal (D006).
3. Remove the snap ring (B005) retaining the shaft seal and support washer.
4. Remove the support washer (M004).
5. Carefully pry out the shaft seal (M003).

To avoid damaging the shaft during removal, install a large sheet metal screw into the chuck of a slide hammer. Drive the screw into the seal surface and use the slide hammer to pull the seal.

6. Discard the seals (D006 and M003).

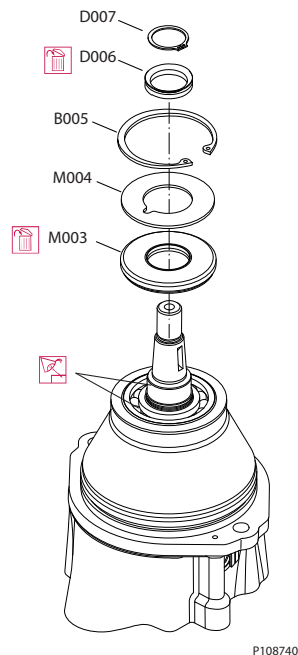

P108740

Inspect the components

Inspect the motor housing seal bore, and the sealing area on the shaft for rust, wear, and contamination. Polish the shaft and clean the housing if necessary.

Install the new shaft seal

1. Cover the shaft with an installation sleeve to protect the shaft and seals during installation.
2. Install a new shaft seal (M003) with the cupped side facing the motor. Press seal into housing until it bottoms out. Press evenly to avoid binding and damaging the seal.
3. Install seal support washer (M004).
4. Install snap ring (B005).
5. Install the dust seal (D006).
6. Install snap ring (D007) to lock the dust seal.
7. Remove the installation sleeve.

Minor repair

Shifting Valve

Remove shifting valve

1. Using a 3mm internal hex wrench, remove screws (E081).
2. Remove valve (E080).
3. Remove and discard O-rings (QE080).

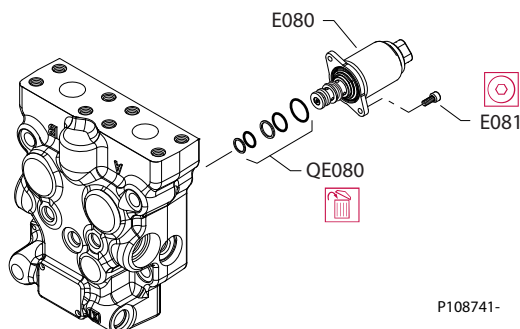

Item	Wrench size	Torque
E081	3 mm	8 Nm [6 lbf-ft]

Inspect the components

Inspect sealing area for rust, wear, or contamination.

Install shifting valve

1. Lubricate and install new O-rings (QE080).
2. Insert valve (E080) into valve seat.
3. Using a 3mm internal hex wrench, install screws (E081). Torque to 2.5 Nm [2 lb•ft].

Anti-Cavitation Valve

Remove the anti-cavitation valve

The anti-cavitation valve is installed into the high pressure port. The high pressure port depends on motor rotation. If forward rotation is counterclockwise, the high pressure port is A. If forward rotation is clockwise, the high pressure port is B.

1. Using a 5/16 in internal hex wrench remove valve plug (E061). Remove and discard O-ring (E063).
2. Remove spring (E012) and relief valve (E011) from end cap.
3. Using a 5/16 in internal hex wrench remove plug (E020).

Standard plugs, with O-rings installed, are included in the overhaul seal kit.

Minor repair

Anti-cavitation valve

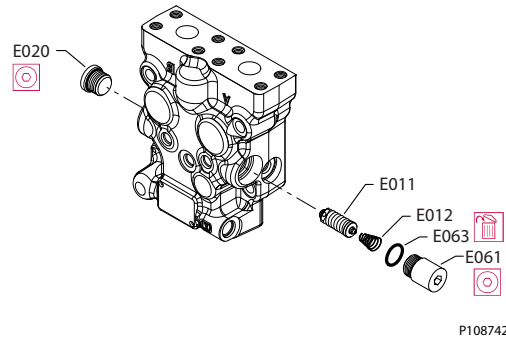

Item	Wrench size	Torque
E061	5/16 inch	80 Nm [59 lbf-ft]
E020	5/16 inch	80 Nm [59 lbf-ft]

Inspect the components

Inspect sealing area for rust, wear, or contamination. Check spring and relief valve for wear and damage. Relief valve is non-serviceable, replace as complete unit if damaged.

Install the anti-cavitation valve

1. Lubricate and insert relief valve (E011) and spring (E012) in original location.
2. Lubricate and install new O-ring (E063) on valve plug (E061).
3. Lubricate O-ring on plug (E020).
4. Using a 5/16 inch internal hex wrench to install valve plug (E061) into the port with a relief valve. Torque to 80 N•m [59 lbf•ft].
5. Using a 5/16 inch internal hex wrench, install plug (E020) into the port without a relief valve. Torque to 80 N•m [59 lbf•ft].

Speed Sensor installation and adjustment

1. Loosen locknut (K011).

Keep all of the old parts until you receive and inventory new parts.

Minor repair

Speed sensor installation

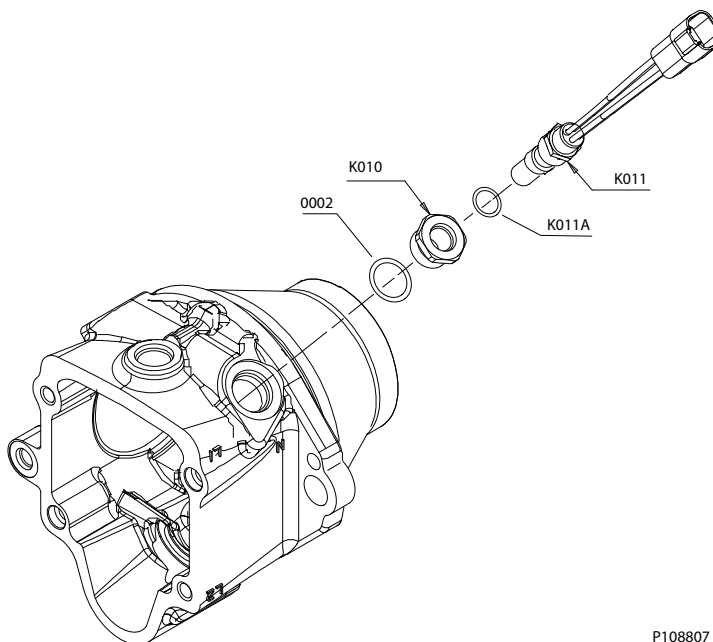

P108807

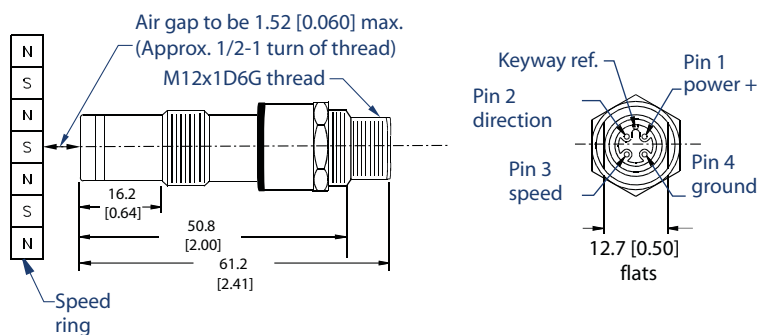

P108806

2. Push the O-ring (K011A) upward, toward the connector end of the sensor unit so that the O-ring does not contact the motor housing during step 3.
3. Thread the sensor (CW) into the motor housing by hand until the bottom end touches the speed ring.
4. Back the sensor out (CCW) 1/2 turn.

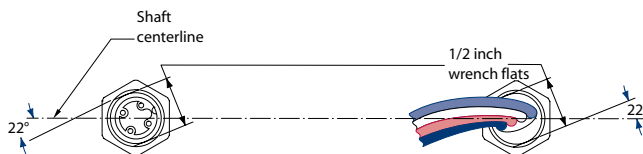

P101332Erev

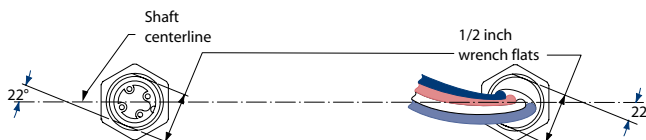

Minor repair

5. Continue backing the sensor out until the flats are 22° either side of the motor shaft center line as shown in the above illustration (20° to 30° is acceptable).
6. Hold the sensor in place with a 1/2 inch wrench. Using an 11/16 inch wrench, torque the locknut (K011) to 13 Nm [10 lbf·ft].

Products we offer:

- Bent Axis Motors
- Closed Circuit Axial Piston Pumps and Motors
- Displays
- Electrohydraulic Power Steering
- Electrohydraulics
- Hydraulic Power Steering
- Integrated Systems
- Joysticks and Control Handles
- Microcontrollers and Software
- Open Circuit Axial Piston Pumps
- Orbital Motors
- PLUS+1® GUIDE
- Proportional Valves
- Sensors
- Steering
- Transit Mixer Drives

Danfoss Power Solutions is a global manufacturer and supplier of high-quality hydraulic and electronic components. We specialize in providing state-of-the-art technology and solutions that excel in the harsh operating conditions of the mobile off-highway market. Building on our extensive applications expertise, we work closely with our customers to ensure exceptional performance for a broad range of off-highway vehicles.

We help OEMs around the world speed up system development, reduce costs and bring vehicles to market faster.

Danfoss – Your Strongest Partner in Mobile Hydraulics.

Go to www.powersolutions.danfoss.com for further product information.

Wherever off-highway vehicles are at work, so is Danfoss. We offer expert worldwide support for our customers, ensuring the best possible solutions for outstanding performance. And with an extensive network of Global Service Partners, we also provide comprehensive global service for all of our components.

Please contact the Danfoss Power Solution representative nearest you.

Comatrol

www.comatrol.com

Schwarzmueller-Inverter

www.schwarzmueller-inverter.com

Turolla

www.turollaocg.com

Hydro-Gear

www.hydro-gear.com

Daikin-Sauer-Danfoss

www.daikin-sauer-danfoss.com

Local address:

Danfoss Power Solutions (US) Company
2800 East 13th Street
Ames, IA 50010, USA
Phone: +1 515 239 6000

Danfoss Power Solutions GmbH & Co. OHG
Krokamp 35
D-24539 Neumünster, Germany
Phone: +49 4321 871 0

Danfoss Power Solutions ApS
Nordborgvej 81
DK-6430 Nordborg, Denmark
Phone: +45 7488 2222

Danfoss Power Solutions Trading (Shanghai) Co., Ltd.
Building #22, No. 1000 Jin Hai Rd
Jin Qiao, Pudong New District
Shanghai, China 201206
Phone: +86 21 3418 5200

Danfoss can accept no responsibility for possible errors in catalogues, brochures and other printed material. Danfoss reserves the right to alter its products without notice. This also applies to products already on order provided that such alterations can be made without changes being necessary in specifications already agreed. All trademarks in this material are property of the respective companies. Danfoss and the Danfoss logotype are trademarks of Danfoss A/S. All rights reserved.