

ENGINEERING
TOMORROW



Technical Information

H1 Axial Piston Single Pumps

Size 045/053



Revision history*Table of revisions*

Date	Changed	Rev
May 2017	NFPE gen. 3 changes.	1001
November 2015	Master Model Code changes.	0900
September 2014	MDC, CCO, and Swash Angle Sensor options added	IA
Mar 2014	Converted to Danfoss layout - DITA CMS	HA
Apr 2013	FDC option added	GA
Mar 2013	AC section updated	FA
Nov 2012	AC added	EA
Feb 2011	Updated drawings	DA
Jun 2010	New EC directive	CA
Feb 2010	14 teeth added	BA
Jul 2009	First edition	AA

Contents

Technical specifications

H1 Pump General Specification.....	5
Technical data H1P 045/053.....	5
Operating parameters H1P 045/053.....	6
Fluid Specifications	6
External radial shaft loads, H1P 045/053.....	7
Bearing life H1 045/053.....	8
Mounting flange loads, H1P 045/053.....	8
Charge pump.....	9
Charge Pump Selection.....	9
Charge pump flow and power curves, 12 cm ³	9

Master Model Code

Control Options

Electrical Displacement Control (EDC).....	17
EDC Control Signal Requirements.....	17
EDC Solenoid Data.....	18
Control Response.....	18
Response time, EDC 045/053.....	19
Manual Displacement Control (MDC)	20
MDC Torque.....	20
MDC General Information.....	21
MDC Shaft Rotation.....	21
Control Response.....	21
Response time, MDC 045/053.....	22
Neutral Start Switch (NSS).....	22
Case Gauge Port M14.....	23
Lever.....	23
Forward-Neutral-Reverse electric control (FNR), options: A9 (12 V) and B1 (24 V).....	24
Control Response.....	25
Response time, FNR 045/053.....	25
Non Feedback Proportional Electric Control (NFPE).....	26
Control Signal Requirements, NFPE 045/053 Single.....	27
Control Response.....	28
Response Time, NFPE 045/053.....	28
Automotive Control (AC).....	29
Mode types.....	29
Basic functions.....	29
Performance functions.....	30
Protection and safety functions.....	30
Engine control and protection.....	30
Installation features.....	30
Fan Drive Control (FDC).....	31
Control Response.....	32
Response time, FDC 045/053.....	32
Manual Over Ride (MOR).....	33
Swash plate angle sensor for NFPE and AC2 controls.....	34
Swash Plate Angle Sensor Parameters.....	34
Swash plate angle sensor connector.....	35
Interface with ECU.....	35
Control-Cut-Off valve (CCO valve).....	36
CCO solenoid data.....	36
Brake gauge port with MDC.....	37
Displacement limiter.....	38
Displacement change (approximately) H1P 045/053 Single.....	38

Dimensions

H1P input shaft, Option G4 (SAE B, 13 teeth).....	39
H1P input shaft, option G1 (SAE B, 14 teeth).....	40
H1P input shaft, option G5 (SAE B-B, 15 teeth).....	41

Contents

H1P input shaft, option F2, Code 25-3.....	42
Tapered shaft customer acknowledgement.....	42
H1P Auxiliary mounting, option H2 (SAE A, 9 teeth).....	43
H1P Auxiliary mounting, option H1 (SAE A, 11 teeth)	43
H1P Auxiliary mounting, option H3 (SAE B, 13 teeth).....	44
H1P Auxiliary mounting, option H5 (SAE B-B, 15 teeth).....	45
H1P displacement limiter, 045/053 Single, option B and D	45
H1P endcap, twin port, Code 62, metric 4 bold FLG, 045/053 S, option D6, D8, F2, and F3.....	46
Speed and temperature sensor, option H (for mounting flange option K).....	46

Installation drawings

H1P single pump ports description.....	47
Dimensions H1P 045/053 Single.....	49

Controls

Electric Displacement Control (EDC), option A2 (12V) / A3 (24V).....	52
Electric Displacement Control (EDC) with MOR, option A4 (12 V) / A5 (24 V).....	53
H1P 045/053 Manual Displacement Control (MDC), option M1.....	54
H1P 045/053 Manual Displacement Control (MDC) with NSS, option M2.....	55
H1P 045/053 Manual Displacement Control (MDC) with CCO, option M3, M4.....	56
H1P 045/053 Manual Displacement Control (MDC) with NSS and CCO, option M5, M6.....	57
Forward-Neutral-Reverse (FNR) with MOR, option A9 (12 V) B1 (24 V)	58
Non Feedback Proportional Electric Control (NFPE) with MOR, options: A8 (12 V) / B8 (24V).....	59
Automotive Control (AC) Dimensions.....	60
Fan Drive Control (FDC), option F1 (12V) / F2 (24V).....	61

Filtration

Suction filtration, option L for H1P 045/053 S.....	62
Remote full flow charge pressure filtration, option P for H1P 045/053 S (for endcap option F).....	63
External full flow charge pressure filtration, option E for H1P 045/053 S.....	64

Technical specifications

H1 Pump General Specification

Design	Axial piston pump of cradle swashplate design with variable displacement
Direction of rotation	Clockwise, Counterclockwise
Pipe connections	<i>Main pressure ports:</i> ISO split flange boss <i>Remaining ports:</i> SAE straight thread O-ring boss
Recommended installation position	Pump installation position is discretionary, however the recommended control position is on the top or at the side with the top position preferred. If the pump is installed with the control at the bottom, flushing flow must be provided through port M14 located on the EDC, FNR and NFPE control. Vertical input shaft installation is acceptable. If input shaft is at the top 1 bar case pressure must be maintained during operation. The housing must always be filled with hydraulic fluid. Recommended mounting for a multiple pump stack is to arrange the highest power flow towards the input source. Consult Danfoss for nonconformance to these guidelines.
Auxiliary cavity pressure	Will be inlet pressure with internal charge pump. For reference see H1P 045/053 Operating Parameters . Will be case pressure with external charge supply. Please verify mating pump shaft seal capability.

Technical data H1P 045/053

Feature	Size 045	Size 053
Displacement	45.0 cm ³ [2.75 in ³]	53.8 cm ³ [3.28 in ³]
Flow at rated (continuous) speed	153 l/min [40 US gal/min]	183 l/min [48 US gal/min]
Torque at maximum displacement (theoretical)	0.72 N·m/bar [437.7 lbf·in/1000 psi]	0.86 N·m/bar [522.0 lbf·in/1000 psi]
Mass moment of inertia of rotating components	0.00465 kg·m ² [0.00343 slug·ft ²]	0.00458 kg·m ² [0.00338 slug·ft ²]
Mass [weight] dry	41 kg [90 lb] (without charge pump or auxiliary mounting flange)	
Oil volume	1.3 l [0.34 US gal]	
Mounting flange	ISO 3019-1 flange 101-2 (SAE B), Special bolt diameter	
Input shaft outer diameter, splines and tapered shafts	ISO 3019-1, outer Ø22 mm - 4 (SAE B, 13 teeth) ISO 3019-1, outer Ø25 mm - 4 (SAE B-B, 15 teeth) ISO 3019-1, outer Ø32 mm - 4 (SAE-B, 14 teeth) Conical keyed shaft end similar to ISO 3019-1 code 25-3, taper 1:8	
Auxiliary mounting flange with metric fasteners, Shaft outer diameter and splines	ISO 3019-1, flange 82 - 2, outer Ø16 mm - 4 (SAE A, 9 teeth) ISO 3019-1, flange 82 - 2, outer Ø19 mm - 4 (SAE A, 11 teeth) ISO 3019-1, flange 101 - 2, outer Ø22 mm - 4 (SAE B, 13 teeth) ISO 3019-1, flange 101 - 2, outer Ø25 mm - 4 (SAE B-B, 15 teeth)	
Suction port	ISO 11926-1 – 1 ⁵ / ₁₆ -12 (SAE O-ring boss)	
Main port configuration	Ø19 mm - 450 bar split flange boss per ISO 6162, M10x1.5 ISO 11926-1 – 1 ⁵ / ₁₆ -12 (SAE O-ring boss)	
Case drain ports L2, L4	ISO 11926-1 – 1 ¹ / ₁₆ -12 (SAE O-ring boss)	
Other ports	SAE O-ring boss	
Customer interface threads	Metric fasteners	

Technical specifications

Operating parameters H1P 045/053

Feature		Size 045	Size 053
Input speed (at minimum charge/ control pressure)	Minimum for internal charge supply ¹⁾	500 min ⁻¹ (rpm)	
	Minimum for external charge supply ²⁾	500 min ⁻¹ (rpm)	
	Minimum for full performance for internal charge supply	1175	1200
	Rated	3400 min ⁻¹ (rpm)	
	Maximum	3500 min ⁻¹ (rpm)	
System pressure	Maximum working pressure	420 bar [6090 psi]	380 bar [5510 psi]
	Maximum pressure	450 bar [6527 psi]	400 bar [5800 psi]
	Maximum low loop	45 bar [650 psi]	
	Minimum low loop pressure	10 bar [145 psi]	
Charge pressure	Minimum	16 bar [232 psi]	
	Maximum	35 bar [508 psi]	
Control pressure	Minimum (at corner power for EDC, MDC, FNR)	21.5 bar [312 psi]	
	Minimum (at corner power for NFPE)	25 bar [363 psi]	
	Maximum	40 bar [580 psi]	
Charge pump inlet pressure	Rated	0.7 bar (absolute) [9 in Hg vacuum]	
	Minimum (cold start)	0.2 bar (absolute) [24 in Hg vacuum]	
	Maximum	4 bar [58 psi]	
Case pressure	Rated	3 bar [44 psi]	
	Maximum	5 bar [73 psi]	
Lip seal external maximum pressure		0.4 [5.8 psi]	

¹⁾ Performance (pressure and displacement) may be limited due to limited control pressure.

²⁾ Full performance (pressure and displacement) possible at minimum charge and control pressure supply.

Fluid Specifications

Viscosity and Temperature range

Feature		Unit	Data
Viscosity	Intermittent ¹⁾	mm ² /s [SUS]	5 [42]
	Minimum		7 [49]
	Recommended range		12 – 80 [66 – 370]
	Maximum		1600 [7500]
Temperature range ²⁾	Minimum ³⁾ (Cold start)	°C [°F]	-40 [-40]
	Recommended range		60 – 85 [140 – 185]
	Rated		104 [220]
	Maximum Intermittent ¹⁾		115 [240]

¹⁾ Intermittent = Short term t < 1 min per incident and not exceeding 2 % of duty cycle based load-life

²⁾ At the hottest point, normally case drain port

³⁾ Cold start = Short term t < 3 min, p ≤ 50 bar [725 psi], n ≤ 1000 min⁻¹ (rpm)

Technical specifications

Filtration, Cleanliness level and Efficiency β_x -ratio (Recommended Minimum)

Cleanliness per ISO 4406	22/18/13
Efficiency β_x (charge pressure filtration)	$\beta_{15-20} = 75$ ($\beta_{10} \geq 10$)
Efficiency β_x (suction and return line Filtration)	$\beta_{35-45} = 75$ ($\beta_{10} \geq 2$)
Recommended inlet screen mesh size	100 – 125 μm

External radial shaft loads, H1P 045/053

H1 pumps are designed with bearings that can accept some external radial loads. The external radial shaft load limits are a function of the load position and orientation, and the operating conditions of the unit. External radial shaft loads impact lifetime. For lifetime calculations please contact Danfoss Power Solutions representative.

The **maximum allowable radial load (R_e)** is based on the maximum external moment (M_e) and the distance (L) from the mounting flange to the load.

$$R_e = \frac{M_e}{L}$$

It may be determined using the following formula:

Radial load position

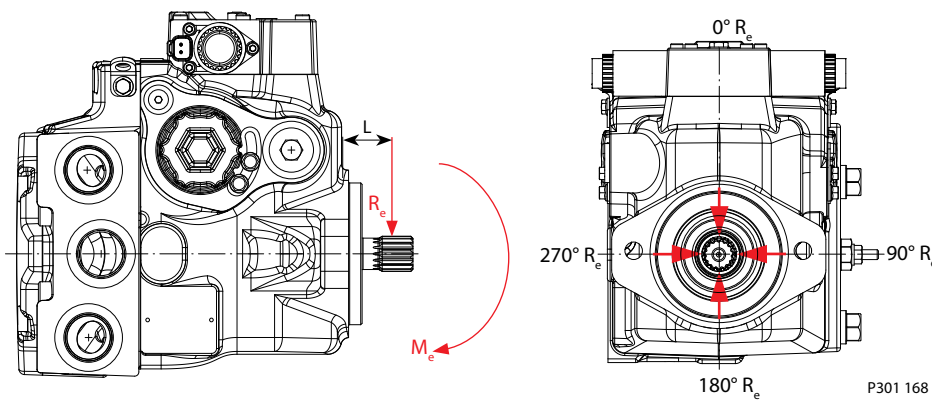

- M_e = shaft moment
- L = flange distance
- R_e = external force to the shaft

Thrust loads should be avoided. Contact Danfoss Power Solutions in the event thrust loads are anticipated.

Technical specifications

Bearing life H1 045/053

Maximum external shaft load based on shaft deflection

External radial moment	Unit	Size 045 / 053
M_e	N·m [lbf·in]	TBD

All external shaft loads affect bearing life. In applications with external shaft loads, minimize the impact by positioning the load at 0° or 180° as shown in the figure.

Danfoss recommends clamp-type couplings for applications with radial shaft loads.

Contact your Danfoss representative for an evaluation of unit bearing life if you have continuously applied external loads exceeding 25 % of the maximum allowable radial load (R_e) or the pump swashplate is positioned on one side of center all or most of the time.

Mounting flange loads, H1P 045/053

The moments shown below apply for control orientation top or side, see below:

Mounting flange loads, Size 045/053, Control on top

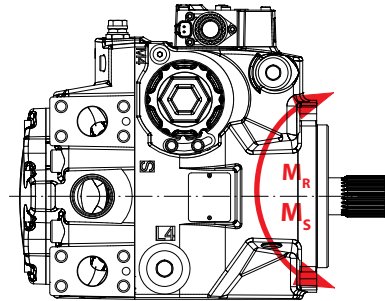

P001 916

Rated moment:

$M_R = 2020 \text{ N}\cdot\text{m}$ [17 880 lbf·in]

Shock load moment:

$M_S = 4110 \text{ N}\cdot\text{m}$ [36 380 lbf·in]

Mounting flange loads, Size 045/053, Control on side

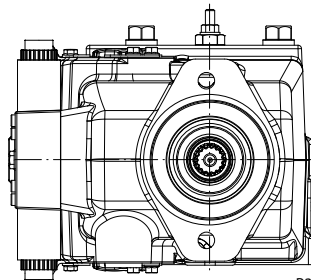

P301 214b

Rated moment:

$M_R = 1300 \text{ N}\cdot\text{m}$ [11 510 lbf·in]

Shock load moment:

$M_S = 2930 \text{ N}\cdot\text{m}$ [25 935 lbf·in]

For more information, see *H1 Axial Piston Pumps, Basic Information*, **BC0000057**, the section “Mounting flange loads”.

Technical specifications

Charge pump

Charge Pump Selection

In most applications a general guideline is that the charge pump displacement should be at least 10% of the total displacement of all components in the system. Unusual application conditions may require a more detailed review of charge flow requirements. System features and conditions which may invalidate the 10% guideline include (but are not limited to):

- Continuous operation at low input speeds <math> < 1500 \text{ min}^{-1} \text{ (rpm)} </math>
- High shock loading and/or long loop lines
- High flushing flow requirements
- Multiple low speed high torque motors
- High input shaft speeds

Contact your Danfoss representative for application assistance if your application includes any of these conditions.

Charge pump flow and power curves, 12 cm³

Charge pressure: 20 bar [290 psi]

Viscosity: 11 mm²/s [63 SUS]

Temperature: 80°C [176°F]

Charge pump flow

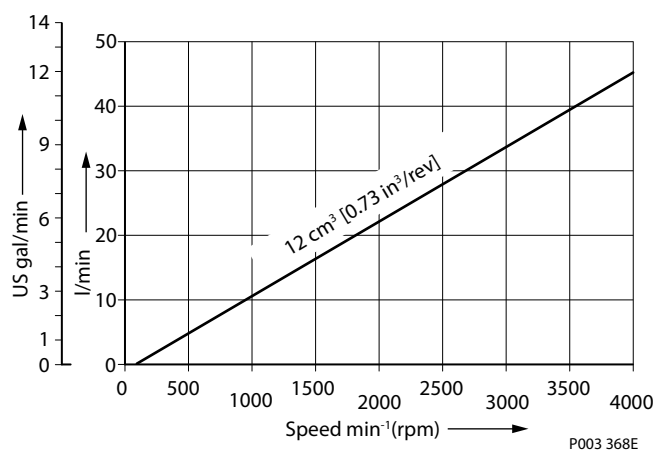

Charge pump power requirements

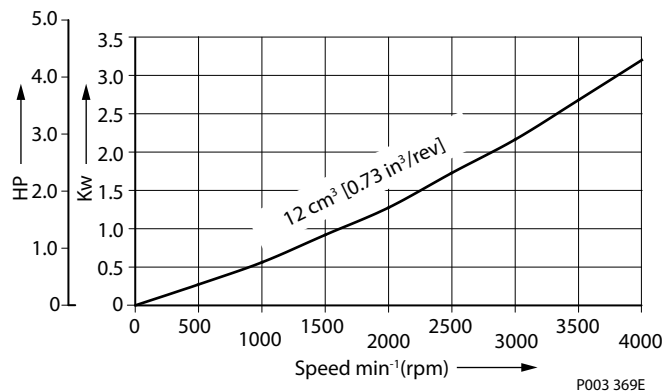

Master Model Code

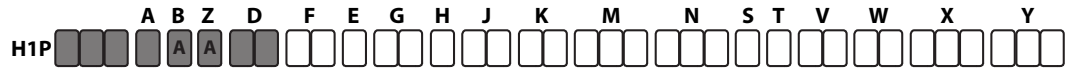

Displacement

045	45.0 cm ³ [2.75 in ³]
053	53.8 cm ³ [3.28 in ³]

A – Rotation

L	Left hand (counter clockwise)
R	Right hand (clockwise)

B – Product version

C	Revision code
----------	---------------

Z – Port configuration

A	Inch, Customer O-ring port sealing according to ISO 11926-1
----------	---

D – Controls — Electric Displacement Control (EDC)

Code	Control type	Voltage	MOR	CCO with key C	DEUTSCH Connector
A2	EDC	12 V	—	—	●
A3	EDC	24 V	—	—	●
A4	EDC	12 V	●	—	●
A5	EDC	24 V	●	—	●
E7	EDC	12 V	—	●	●
E8	EDC	24 V	—	●	●

● – To be used for the control; — Not to be used for the control

D – Controls (continued) — Non Feedback Proportional Electric Control (NFPE)

Code	Control type	Voltage	MOR	CCO with key C	Angle sensor	DEUTSCH Connector
N1	NFPE	12 V	●	—	—	●
N2	NFPE	24 V	●	—	—	●
N3	NFPE	12 V	—	●	●	●
N4	NFPE	24 V	—	●	●	●
N5	NFPE	12 V	●	—	●	●
N6	NFPE	24 V	●	—	●	●
N7	NFPE	12 V	—	●	—	●
N8	NFPE	24 V	—	●	—	●

Align with options: **E**: Displacement limiters and **W**: Special hardware.

Master Model Code

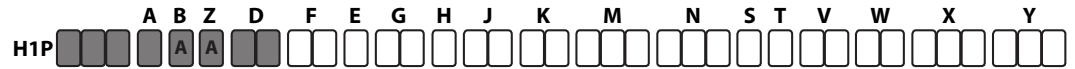

D – Controls (continued) — Automotive Control (AC)

Code	AC type	Voltage	MOR	Speed sensor	Wire harness	Angle sensor	DEUTSCH Connector
P6	AC-1	12 V	●	●	●	—	●
P7	AC-1	24 V	●	●	●	—	●
P8	AC-2	12 V	●	●	●	●	●
P9	AC-2	24 V	●	●	●	●	●
P5	AC-1	12 V	●	—	—	—	●
R3	AC-1	24 V	●	—	—	—	●
R4	AC-2	12 V	●	—	—	●	●
R5	AC-2	24 V	●	—	—	●	●

● – To be used for the control; — Not to be used for the control

D – Controls (continued) — Manual Displacement Control (MDC)

Code	Control type	CCO Voltage	CCO	Neutral Start Switch	DEUTSCH Connector
M1	MDC	—	—	—	—
M2	MDC	—	—	●	●
M3	MDC	12 V	●	—	●
M4	MDC	24 V	●	—	●
M5	MDC	12 V	●	●	●
M6	MDC	24 V	●	●	●

Align with options **F**: Orifices and **Y**: Settings for adjustment (if applicable).

D – Controls (continued) — Fan Drive Control (FDC)

Code	Control type	Voltage	DEUTSCH Connector
F1	FDC	12 V	●
F2	FDC	24 V	●

Align with options: **F**: Orifices, **E**: Displacement limiters, **M, N**: Overpressure protection, and **W**: Special hardware.

Master Model Code



F – Orifices

Code	Orifice			Controls: To be used for (●) / NOT to be used for (-)			
	Tank (A+B)	P	A / B	EDC, FNR	MDC	NFPE, AC	FDC
C3	No orifice			●	●	-	-
C1	-	-	0.8 mm	●	●	●	-
C2	-	-	1.3 mm	●	●	●	●
C4	-	-	1.8 mm	●	●	●	-
C6	1.0 mm	-	-	-	●	-	-
C7	1.3 mm	-	-	-	●	-	-
C8	0.6 mm	0.8 mm	-	-	●	-	-
C9	0.6 mm	1.0 mm	-	-	●	-	-
D1	0.8 mm	1.0 mm	-	-	●	-	-
D2	0.8 mm	1.3 mm	-	-	●	-	-
D3	1.0 mm	1.3 mm	-	-	●	-	-
D4	1.0 mm	1.3 mm	1.3 mm	-	●	-	-
D5	0.6 mm	0.6 mm	0.8 mm	-	●	-	-
D8	-	-	2.3 mm	-	-	●	-

E – Displacement limiter

N	None
C	No limiters, with nested springs, required for NFPE, AC, FDC *
B	Adjustable externally
D	Adjustable externally with nested springs, required for NFPE, AC, FDC *

* Align with option Y: Settings for adjustment (if applicable).ima1444887758105

Master Model Code



G – Endcap options (Twin port, ISO 6162 split flange ports)

Align the option <i>K: Auxiliary mounting pad 11 926 O-ring ports</i> with options: <i>M + N</i> and <i>T</i> below:				
Code	With pressure limiter		Without pressure limiter(HPRV only)	
	Suction filtration	Remote or external charge supply for full charge flow filtration	Suction filtration	Remote or external charge supply for full charge flow filtration
E5	-	●	-	-
E6	●	-	-	-
E9	-	-	-	●
F1	-	-	●	-
Align the option <i>K: Auxiliary mounting pad ISO 6162 split flange ports</i> with options <i>M + N</i> and <i>T</i> below:				
D6	●	-	-	-
D8	-	●	-	-
F2	-	-	-	●
F3	-	-	●	-

H – Mounting

F	ISO 3019-1, flange 101-2 (SAE B)
J	ISO 3019-1, flange 101-2 (SAE B), 2-bolt and speed sensor

J – Input shaft

A1	ISO 3019-1, (SAE-C, 17 teeth splined shaft, 12/24 pitch)
G1	ISO 3019-1, outer Ø32 mm - 4 (SAE C, 14 teeth splined shaft 12/24 pitch)
G3	ISO 3019-1, (SAE-C, 13 teeth splined shaft, 8/16 pitch)
G4	ISO 3019-1, outer Ø22 mm - 4 (SAE B, 13 teeth splined shaft 16/32 pitch)
G5	ISO 3019-1, outer Ø25 mm - 4 (SAE B, 15 teeth splined shaft 16/32 pitch)
F2	Conical keyed shaft end similar to ISO 3019-1 code 25-3, taper 1:8 (key not supplied with pump)

K – Auxiliary mounting pad ISO 3019-1 (Align with option G: Endcap selection)

NN	None	Shipping cover
H1	Flange 82 - 2, outer Ø19 mm - 4 (SAE A, 11 teeth 16/32 coupling)	
H2	Flange 82 - 2, outer Ø16 mm - 4 (SAE A, 9 teeth 16/32 coupling)	
H3	Flange 101 - 2, outer Ø22 mm - 4 (SAE B, 13 teeth 16/32 coupling)	
H5	Flange 101 - 2, outer Ø25 mm - 4 (SAE B-B, 15 teeth 16/32 coupling)	
S1	Flange 101-2, outer Ø22mm-4 (SAE-B 14 teeth 12/24 coupling, not SAE standard)	

Master Model Code

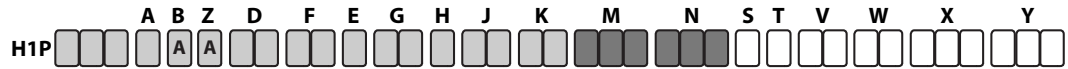

M – Overpressure protection type, side “A”
N – Overpressure protection type, side “B”

Pressure limiter and HPRV with bypass, pressure protection type must be the same for side “A” and “B”		
L ¹⁾	Pressure limiter setting	HPRV setting
L15	150 bar [2900 psi]	200 bar [2900 psi]
L18	180 bar [2610 psi]	250 bar [3630 psi]
L20	200 bar [2900 psi]	250 bar [3630 psi]
L23	230 bar [3336 psi]	280 bar [4061 psi]
L25	250 bar [3630 psi]	300 bar [4350 psi]
L28	280 bar [4061 psi]	330 bar [4786 psi]
L30	300 bar [4350 psi]	350 bar [5076 psi]
L33	330 bar [4786 psi]	380 bar [5510 psi]
L35	350 bar [5076 psi]	400 bar [5800 psi]
L38	380 bar [5510 psi]	420 bar [6090 psi]
L40	400 bar [5800 psi] (45 cm ³ only)	450 bar [6526 psi]
L42	420 bar [6090 psi] (45 cm ³ only)	450 bar [6526 psi]
F01	150 bar [2175 psi]	250 bar [3630 psi]
F02	150 bar [2175 psi]	300 bar [4350 psi]

High pressure relief valve with bypass, pressure protection type must be the same for side “A” and “B”	
K ¹⁾	Pressure setting ²⁾
K18	180 bar [2610 psi]
K20	200 bar [2900 psi]
K23	230 bar [3336 psi]
K25	250 bar [3630 psi]
K28	280 bar [4061 psi]
K30	300 bar [4350 psi]
K33	330 bar [4786 psi]
K35	350 bar [5080 psi]
K38	380 bar [5510 psi]
K40	400 bar [5800 psi] (45 cm ³ only)
K42	420 bar [6090 psi] (45 cm ³ only)

¹⁾ L, F – with pressure limiter; K – without pressure limiter.

²⁾ Please contact Danfoss Power Solutions for pressures not shown or for applied pressure above max. working pressure (see [Operating parameters H1P 045/053](#) on page 6).

Master Model Code



S – Charge pump

B	12 cm ³ /rev [0.73 in ³ /rev]
N	No charge pump, external charge supply (<i>Align with options: E and T</i>)

T – Filtration (Align with option G: Endcap selection)

L	Suction filtration (see Suction filtration, option L for H1P 045/053 S on page 62)
P	Remote full charge flow filtration
E	External charge flow filtration (<i>Align with options: N and S</i>)
N	Integral charge full flow filtration with Bypass sensor, no filter cartridge

V – Charge pressure relief setting

18	18 bar [261 psi]	Not to be used for NFPE, AC and FDC controls.
20	20 bar [290 psi]	
22	22 bar [319 psi]	
24	24 bar [348 psi]	
26	26 bar [377 psi]	
28	28 bar [406 psi]	
30	30 bar [435 psi]	
32	32 bar [464 psi]	

W – Special hardware features

PN	EDC / FNR / MDC valve plate
P1	NFPE valve plate (<i>Align with options: D and E</i>)
P2	NFPE / FDC / AC valve plate and speed ring on the cylinder block
P4	EDC / FNR / MDC valve plate with speed ring on the cylinder block (<i>Align with options: D and E</i>)
H1	MDC / EDC / FNR valve plate with MDC handle

X – Paint and nametag

NNN	Black paint and Danfoss nametag
------------	---------------------------------

Master Model Code

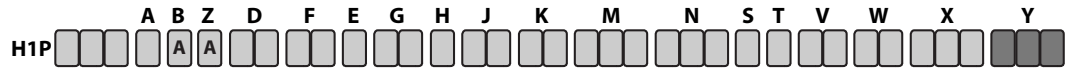

Y – Special settings (SIL-2 non-certifiable, without customer files)

Code	CAN J1939	ECO fuel saving mode	Functional option	Cruise control	Control	AC type
D3E	in/out	●	E	–	N1 (12 V _{DC})	AC-1
D3F	in/out	–	F	–		
D4E	in/out	●	E	–	N2 (24 V _{DC})	
D4F	in/out	–	F	–		
D5F	in/out	–	F	–	P8 (12 V _{DC})	AC-2 with Swash Plate Angle Sensor
D5J	in/out	●	J	●		
D6F	in/out	–	F	–	P9 (24 V _{DC})	
D6J	in/out	●	J	●		
M00	MDC handle standard position					
NNN	None					

● = available option
 – = not available option

Control Options

Electrical Displacement Control (EDC)

The Electrical Displacement Control (EDC) consists of a pair of proportional solenoids on each side of a three-position, four-way porting spool. The proportional solenoid applies a force input to the spool, which ports hydraulic pressure to either side of a double acting servo piston.

Differential pressure across the servo piston rotates the swashplate, changing the pump's displacement from full displacement in one direction to full displacement in the opposite direction.

Under some circumstances, such as contamination, the control spool could stick and cause the pump to stay at some displacement. A serviceable 125 µm screen is located in the supply line immediately before the control porting spool.

Electrical Displacement Control, with hydraulic schematic

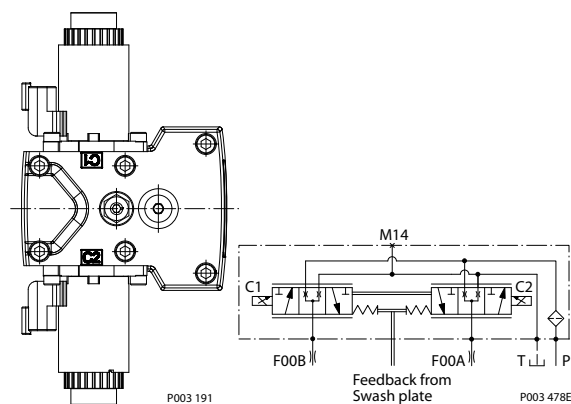

Pump displacement vs. control current

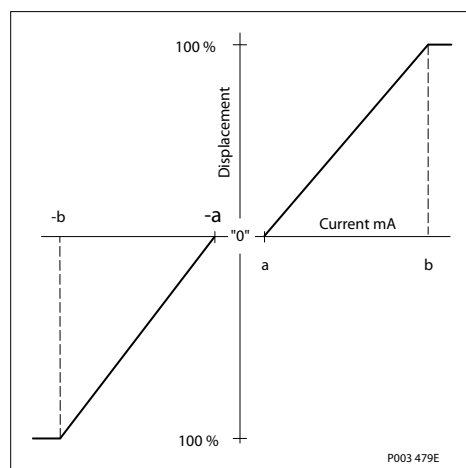

EDC Control Signal Requirements

Control minimum current to stroke pump

Voltage	a*	b	Pin connections
12 V	640 mA	1640 mA	any order
24 V	330 mA	820 mA	

* Factory test current, for vehicle movement or application actuation expect higher or lower value.

Control Options

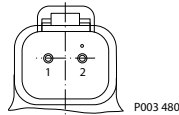

Connector ordering data

Description	Quantity	Ordering data
Mating connector	1	DEUTSCH DT06-2S
Wedge lock	1	DEUTSCH W2S
Socket contact (16 and 18 AWG)	2	DEUTSCH 0462-201-16141
Danfoss mating connector kit	1	K29657

EDC Solenoid Data

Solenoid data

Description		12 V	24 V
Maximum current		1800 mA	920 mA
Nominal coil resistance	@ 20 °C [68 °F]	3.66 Ω	14.20 Ω
	@ 80 °C [176 °F]	4.52 Ω	17.52 Ω
Inductance		33 mH	140 mH
PWM signal frequency	Range	70 – 200 Hz	
	Recommended*	200 Hz	
IP Rating	IEC 60 529	IP 67	
	DIN 40 050, part 9	IP 69K with mating connector	
Connector color		Black	

* PWM signal required for optimum control performance.

Pump output flow direction vs. control signal

Shaft rotation	CW		CCW	
	C1	C2	C1	C2
Coil energized*				
Port A	out	in	in	out
Port B	in	out	out	in
Servo port pressurized	M4	M5	M4	M5

* For coil location see Installation drawings.

Control Response

H1 controls are available with optional control passage orifices to assist in matching the rate of swashplate response to the application requirements (e.g. in the event of electrical failure). The time required for the pump output flow to change from zero to full flow (acceleration) or full flow to zero (deceleration) is a net function of spool porting, orifices, and charge pressure. A swashplate response table is available for each frame indicating available swashplate response times. Testing should be conducted to verify the proper orifice selection for the desired response.

[H1 pumps are limited in mechanical orificing combinations. Mechanical servo orifices are to be used only for fail-safe return to neutral in the event of an electrical failure.](#)

Control Options

Typical response times at the following conditions:

Δp	250 bar [3626 psi]
Viscosity and temperature	30 mm ² /s [141 SUS] and 50 °C [122 °F]
Charge pressure	20 bar [290 psi]
Speed	1800 min ⁻¹ (rpm)

Response time, EDC 045/053

Stroking direction	0.8 mm [0.03 in] orifice	1.3 mm [0.05 in] orifice	No orifice
Neutral to full flow	1.7 s	0.9 s	0.5 s
Full flow to neutral	1.1 s	0.6 s	0.3 s

Control Options

Manual Displacement Control (MDC)

A Manual proportional Displacement Control (**MDC**) consists of a handle on top of a rotary input shaft. The shaft provides an eccentric connection to a feedback link. This link is connected on its one end with a porting spool. On its other end the link is connected the pumps swashplate.

This design provides a travel feedback without spring. When turning the shaft the spool moves thus providing hydraulic pressure to either side of a double acting servo piston of the pump.

Differential pressure across the servo piston rotates the swash plate, changing the pump's displacement. Simultaneously the swashplate movement is fed back to the control spool providing proportionality between shaft rotation on the control and swashplate rotation.

The MDC changes the pump displacement between no flow and full flow into opposite directions. Under some circumstances, such as contamination, the control spool could stick and cause the pump to stay at some displacement.

A serviceable 125 µm screen is located in the supply line immediately before the control porting spool.

The MDC is sealed by means of a static O-ring between the actuation system and the control block. Its shaft is sealed by means of a special O-ring which is applied for low friction. The special O-ring is protected from dust, water and aggressive liquids or gases by means of a special lip seal.

Manual Displacement Control

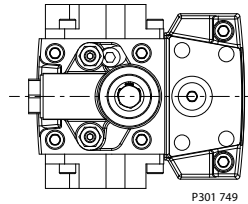

Pump displacement vs. control lever rotation

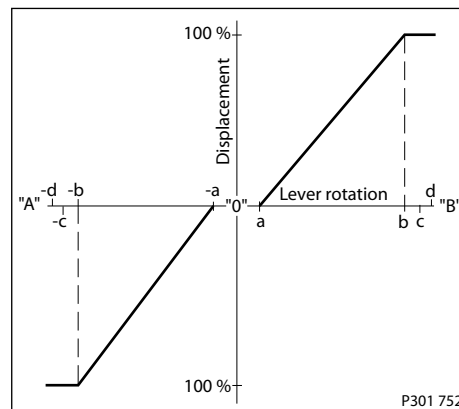

Legend:

Deadband on **B** side – $a = 3^\circ \pm 1^\circ$

Maximum pump stroke – $b = 30^\circ +2/-1^\circ$

Required customer end stop – $c = 36^\circ \pm 3^\circ$

Internal end stop – $d = 40^\circ$

MDC Torque

Description	Value
Torque required to move handle to maximum displacement	1.4 N·m [12.39 lbf·in]
Torque required to hold handle at given displacement	0.6 N·m [5.31 lbf·in]
Maximum allowable input torque	20 N·m [177 lbf·in]

Control Options

! Caution

Volumetric efficiencies of the system will have impacts on the start and end input commands.

MDC General Information

In difference to other controls the MDC provides a mechanical deadband. This is required to overcome the tolerances in the mechanical actuation.

The MDC contains an internal end stop to prevent over travel. The restoring moment is appropriate for turning the MDC input shaft back to neutral only. Any linkages or cables may prevent the MDC from returning to neutral.

The MDC is designed for a maximum case pressure of 5 bar and a rated case pressure of 3 bar. If the case pressure exceeds 5 bar there is a risk of an insufficient restoring moment. In addition a high case pressure can cause the NSS to indicate that the control is not in neutral. High case pressure may cause excessive wear.

Customers can apply their own handle design but they must care about a robust clamping connection between their handle and the control shaft and avoid overload of the shaft.

Customers can connect two MDC's on a tandem unit in such a way that the actuation force will be transferred from the pilot control to the second control but the kinematic of the linkages must ensure that either control shaft is protected from torque overload. To avoid an overload of the MDC, customers must install any support to limit the setting range of the Bowden cable.

! Caution

Using the internal spring force on the input shaft is not an appropriate way to return the customer connection linkage to neutral.

MDC Shaft Rotation

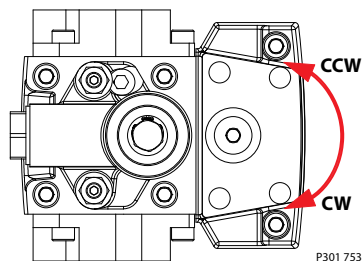

MDC shaft rotation data

Pump shaft rotation*	Clock Wise (CW)		Counter Clock Wise (CCW)	
	CW	CCW	CW	CCW
Port A	in (low)	out (high)	out (high)	in (low)
Port B	out (high)	in (low)	in (low)	out (high)
Servo port high pressure	M5	M4	M5	M4

* As seen from shaft side.

Control Response

H1 controls are available with optional control passage orifices to assist in matching the rate of swashplate response to the application requirements (e.g. in the event of electrical failure). The time required for the pump output flow to change from zero to full flow (acceleration) or full flow to zero (deceleration) is a net function of spool porting, orifices, and charge pressure. A swashplate response table is available for each frame indicating available swashplate response times. Testing should be conducted to verify the proper orifice selection for the desired response.

Control Options

H1 pumps are limited in mechanical orificing combinations. Mechanical servo orifices are to be used only for fail-safe return to neutral in the event of an electrical failure.

Typical response times at the following conditions:

Δp	250 bar [3626 psi]
Viscosity and temperature	30 mm ² /s [141 SUS] and 50 °C [122 °F]
Charge pressure	20 bar [290 psi]
Speed	1800 min ⁻¹ (rpm)

Response time, MDC 045/053

Code	Orifice description (mm)				Stroking direction (sec)	
	P	A	B	Tank (A+B)	Neutral to full flow	Full flow to neutral
C3	–	–	–	–	0.3	0.4
C6	–	–	–	1	0.9	0.8
C7	–	–	–	1.3	0.6	0.6
C8	0.8	–	–	0.6	2.9	2.0
C9	1	–	–	0.6	2.7	1.9
D1	1	–	–	0.8	1.7	1.2
D2	1.3	–	–	0.8	1.5	1.1
D3	1.3	–	–	1	1.1	0.8
D4	1.3	1.3	1.3	1	1.3	1.0
D5	0.6	0.8	0.8	0.6	5.4	2.8

Neutral Start Switch (NSS)

The Neutral Start Switch (**NSS**) contains an electrical switch that provides a signal of whether the control is in neutral. The signal in neutral is Normally Closed (**NC**).

Neutral Start Switch schematic

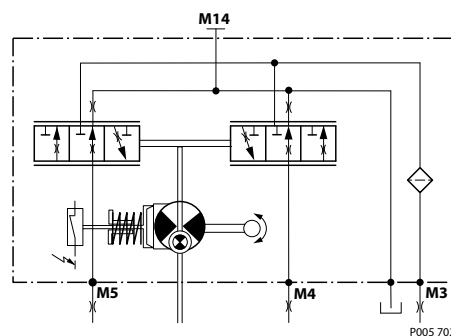

Neutral Start Switch data

Max. continuous current with switching	8.4 A
Max. continuous current without switching	20 A
Max. voltage	36 V _{DC}
Electrical protection class	IP67 / IP69K with mating connector

Control Options

Case Gauge Port M14

The drain port should be used when the control is mounted on the unit's bottom side to flush residual contamination out of the control.

MDC schematic diagram

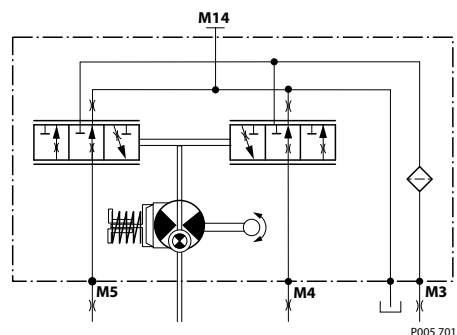

Lever

MDC-controls are available with an integrated lever.

Control Options

Forward-Neutral-Reverse electric control (FNR), options: A9 (12 V) and B1 (24 V)

The 3-position **FNR** control uses an electric input signal to switch the pump to a full stroke position. Under some circumstances, such as contamination, the control spool could stick and cause the pump to stay at some displacement. A serviceable 125 µm screen is located in the supply line immediately before the control porting spool.

Forward-Neutral-Reverse electric control (FNR) FNR hydraulic schematic

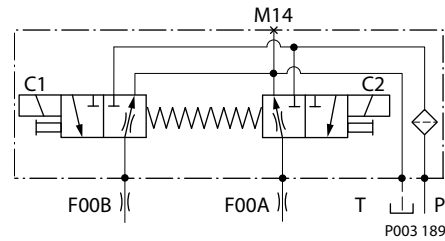
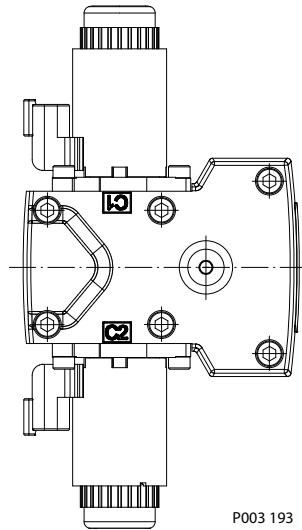

Pump displacement vs. electrical signal

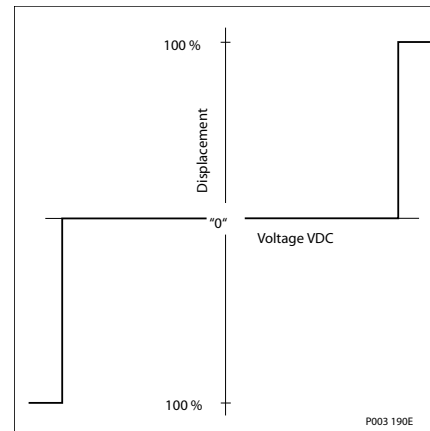

Control current

Voltage	Min. current to stroke pump	Pin connections
12 V	750 mA	any order
24 V	380 mA	

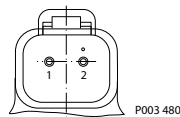

Connector ordering data

Description	Quantity	Ordering data
Mating connector	1	DEUTSCH DT06-2S
Wedge lock	1	DEUTSCH W2S
Socket contact (16 and 18 AWG)	2	DEUTSCH 0462-201-16141
Danfoss mating connector kit	1	K29657

Control Options

Solenoid data

Voltage	12 V	24 V
Minimum supply voltage	9.5 V _{DC}	19 V _{DC}
Maximum supply voltage (continuous)	14.6 V _{DC}	29 V _{DC}
Maximum current	1050 mA	500 mA
Nominal coil resistance @ 20 °C [70 °F]	8.4 Ω	34.5 Ω
PWM Range	70-200 Hz	
PWM Frequency (preferred)*	100 Hz	
IP Rating (IEC 60 529) + DIN 40 050, part 9	IP 67 / IP 69K (part 9 with mating connector)	
Bi-directional diode cut off voltage	28 V _{DC}	53 V _{DC}

* PWM signal required for optimum control performance.

Pump output flow direction vs. control signal

Shaft rotation	CW		CCW	
	C1	C2	C1	C2
Coil energized*				
Port A	in	out	out	in
Port B	out	in	in	out
Servo port pressurized	M5	M4	M5	M4

* For coil location see [Installation drawings](#) on page 47.

Control Response

H1 controls are available with optional control passage orifices to assist in matching the rate of swashplate response to the application requirements (e.g. in the event of electrical failure). The time required for the pump output flow to change from zero to full flow (acceleration) or full flow to zero (deceleration) is a net function of spool porting, orifices, and charge pressure. A swashplate response table is available for each frame indicating available swashplate response times. Testing should be conducted to verify the proper orifice selection for the desired response.

[H1 pumps are limited in mechanical orificing combinations. Mechanical servo orifices are to be used only for fail-safe return to neutral in the event of an electrical failure.](#)

Typical response times at the following conditions:

Δp	250 bar [3626 psi]
Viscosity and temperature	30 mm ² /s [141 SUS] and 50 °C [122 °F]
Charge pressure	20 bar [290 psi]
Speed	1800 min ⁻¹ (rpm)

Response time, FNR 045/053

Stroking direction	0.8 mm [0.03 in] Orifice	1.3 mm [0.05 in] Orifice	No orifice
Neutral to full flow	1.8 s	0.9 s	0.5 s
Full flow to neutral	1.6 s	0.8 s	0.4 s

Control Options

Non Feedback Proportional Electric Control (NFPE)

The Non Feedback Proportional Electric (**NFPE**) control is an electrical automotive control in which an electrical input signal activates one of two proportional solenoids that port charge pressure to either side of the pump servo cylinder. The NFPE control has no mechanical feedback mechanism.

A serviceable 170 µm screen is located in the supply line immediately before the control porting spool.

Non Feedback Proportional Electric Control

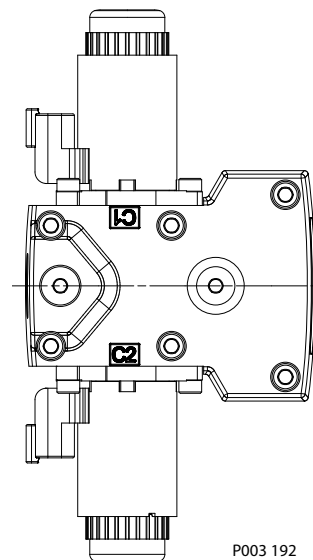

NFPE schematic

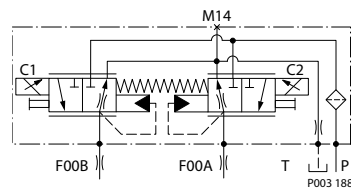

The pump displacement is proportional to the solenoid signal current, but it also depends upon pump input speed and system pressure. This characteristic also provides a power limiting function by reducing the pump swashplate angle as system pressure increases. A typical response characteristic is shown in the accompanying graph. Under some circumstances, such as contamination, the control spool could stick and cause the pump to stay at some displacement.

Control Options

Pump displacement vs. input signal

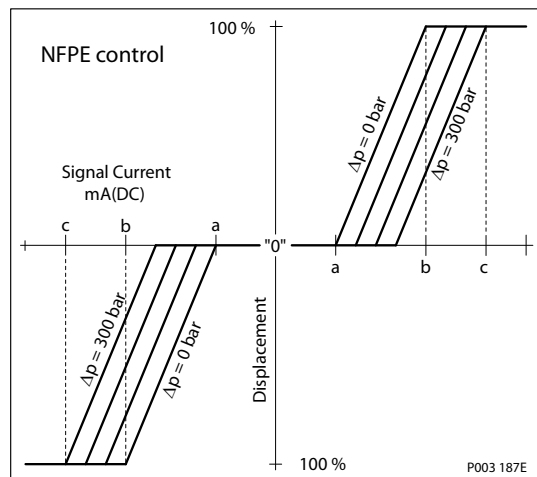

Control Signal Requirements, NFPE 045/053 Single

Control current

Voltage	a*	b	c	Pin connections
12 V	310 mA	1050 mA	1540 mA	any order
24 V	309 mA	551 mA	770 mA	

* Factory test current, for vehicle movement or application actuation expect higher or lower value.

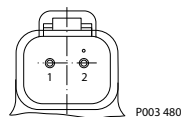

Connector ordering data

Description	Quantity	Ordering data
Mating connector	1	DEUTSCH DT06-2S
Wedge lock	1	DEUTSCH W2S
Socket contact (16 and 18 AWG)	2	DEUTSCH 0462-201-16141
Danfoss mating connector kit	1	K29657

Solenoid data

Description		12 V	24 V
Maximum current		1800 mA	920 mA
Nominal coil resistance	@ 20 °C [68 °F]	3.66 Ω	14.20 Ω
	@ 80 °C [176 °F]	4.52 Ω	17.52 Ω
Inductance		33 mH	140 mH
PWM signal frequency	Range	70 – 200 Hz	
	Recommended*	200 Hz	

Control Options

Solenoid data (continued)

Description		12 V	24 V
IP Rating	IEC 60 529	IP 67	
	DIN 40 050, part 9	IP 69K with mating connector	
Connector color		Black	

* PWM signal required for optimum control performance.

Pump output flow direction vs. control signal

Shaft rotation	CW		CCW	
	C1	C2	C1	C2
Port A	in	out	out	in
Port B	out	in	in	out
Servo port pressurized	M5	M4	M5	M4

* For coil location see Installation drawings.

Control Response

H1 controls are available with optional control passage orifices to assist in matching the rate of swashplate response to the application requirements (e.g. in the event of electrical failure). The time required for the pump output flow to change from zero to full flow (acceleration) or full flow to zero (deceleration) is a net function of spool porting, orifices, and charge pressure. A swashplate response table is available for each frame indicating available swashplate response times. Testing should be conducted to verify the proper orifice selection for the desired response.

[H1 pumps are limited in mechanical orificing combinations. Mechanical servo orifices are to be used only for fail-safe return to neutral in the event of an electrical failure.](#)

Typical response times at the following conditions:

Δp	250 bar [3626 psi]
Viscosity and temperature	30 mm ² /s [141 SUS] and 50 °C [122 °F]
Charge pressure	20 bar [290 psi]
Speed	1800 min ⁻¹ (rpm)

Response Time, NFPE 045/053

Stroking direction	0.8 mm [0.03 in] orifice	1.3 mm [0.05 in] orifice	2.3 mm [0.09 in] orifice
Neutral to full flow	1.8 s	0.8 s	0.3 s
Full flow to neutral	1.2 s	0.5 s	0.2 s

Control Options

Automotive Control (AC)

The H1 **Automotive Control (AC)** is an electric NFPE Control with an integrated microcontroller, installed on the pump. The integrated microcontroller enhanced control performance with a flexible, configurable control scheme for an entire single path propel transmission. It can be used in combination with fixed and variable displacement hydraulic-motors. With the pre-installed application software and easily changeable control parameters, it is possible to tailor the vehicle's driving behavior to the individual requirements of the customer.

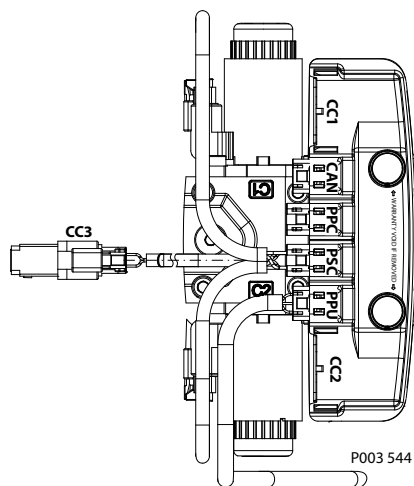

The H1 Automotive Control is divided into 2 systems:

- AC-1
- AC-2

AC-2 is an extension of AC-1 that features an integrated pump swash plate angle sensor and software enabled functions such as Swash Plate Control.

Mode types

The application software provides 3 different hydrostatic propel methods, defined as mode types, which can be used individually.

- **Automotive Load dependent** (torque controlled) driving behavior. Setpoint for the drive curve is the engine rpm.
- **Non-Automotive Load independent** (speed controlled) driving mode. Setpoint for the drive curve is a Joystick or drive pedal signal, independent of the engine rpm. The best performance will be achieved with an AC-2 Swash Plate Angle Sensor.
- **Creep-Automotive Load dependent** (torque controlled) driving behavior (like Automotive). Setpoint for the drive curve is the engine rpm. The setpoint can be reduced by the creep potentiometer if a high engine rpm in combination with low vehicle speed is needed.

Basic functions

- Four selectable system modes, selectable via switch.
- Individual settings for forward and reverse driving direction (4 x 2 curves).
- Independent pump and hydraulic-motor profiling and ramping for each mode.
- Electric drive pedal connection
- Electronic inching function without separate control valve
- Electric creep mode potentiometer

Control Options

- Configurable System Mode & Direction change
- Load independent pump displacement control with integrated Swash Plate Angle Sensor (AC-2)
- Hydraulic-motor displacement control including brake pressure defeat function

Performance functions

- ECO fuel saving mode with automatic reduction of the engine speed during transport (Cruise control)
- Vehicle constant speed drive control
- Vehicle speed limitation
- Dynamic brake light, automatic park brake, reverse buzzer and status LED outputs
- Vehicle speed controlled output function.
- Temperature compensation for predictable performance
- Advanced CAN J1939 interface for the information exchange with the vehicle control system

Protection and safety functions

- Safety controlled vehicle start protection with engine speed check, battery check and FNR must be in neutral, etc..
- Operator presence detection
- Hydraulic system overheat and low-temperature protection
- Hydraulic motor over speed protection
- Park brake test mode for roller applications to fulfill SAE J1472 / EN500-4.
- SIL2 compliant

Engine control and protection

- CAN J1939 engine interface
- Engine speed control via drive pedal with safety controlled monitoring function
- Engine antistall protection
- Engine over speed protection during inching
- Engine speed dependent Retarder control
- Engine cold start protection

Installation features

- Factory calibration for hysteresis compensation.
- Starting current adjustment in the factory
- Pre-installed application software and parameter files

For more information, see [Automotive Control for H1 Single Pumps Technical Information, BC00000213](#).

Control Options

Fan Drive Control (FDC)

The Fan Drive Control (**FDC**) is a non-feedback control in which an electrical input signal activates the proportional solenoid that ports charge pressure to either side of the pump servo cylinder. The single proportional solenoid is used to control pump displacement in the forward or reverse direction. The control spool is spring biased to produce maximum forward pump displacement in the absence of an electrical input signal. Based on the spring bias spool default forward flow for a CW rotation pump is out of Port B while default forward flow for a CCW rotation pump is out of Port A.

The pump displacement is proportional to the solenoid signal current, but it also depends upon pump input speed and system pressure. This characteristic also provides a power limiting function by reducing the pump swashplate angle as system pressure increases. The pump should be configured with 0.8 mm control orifices to provide slowest response and maximize system stability. Additionally pressure limiter (PL) valves are used to limit maximum fan trim speed in both (forward and reverse) directions.

FDC control

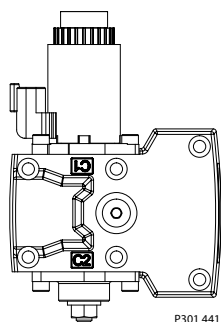

FDC hydraulic schematic

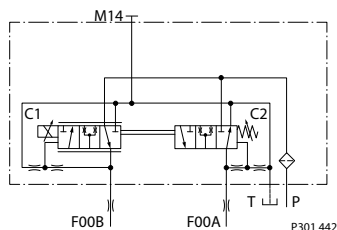

H1 pumps with FDC will be delivered from factory with nominal PL setting of 150 bar [2175 psi]. The PL must be re-adjusted to ensure that the fan reaches the desired fan speed to satisfy the cooling needs of the system. HPRV setting must be always at least 30 bar [435 psi] higher than PL setting.

Under some circumstances, such as contamination, the control spool could stick and cause the pump to stay at some displacement.

For more information necessary to properly size and configure a hydraulic fan drive system, see *Hydraulic Fan Drive Design Guidelines* **AB00000019**.

Use in other systems could result in unintended movement of the machine or it's elements. Loss of the input signal to this control will cause the pump to produce maximum flow.
The FDC is for Fan Drive systems only!

Control Options

Pump displacement vs. control current

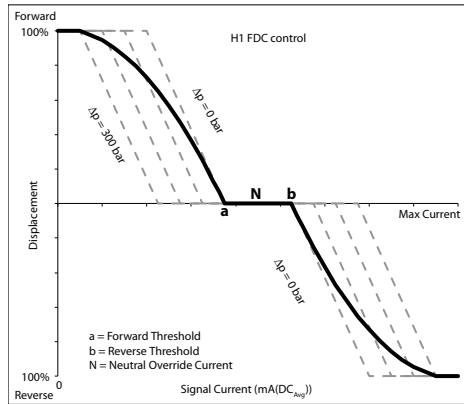

P301 443

Control Response

H1 controls are available with optional control passage orifices to assist in matching the rate of swashplate response to the application requirements (e.g. in the event of electrical failure). The time required for the pump output flow to change from zero to full flow (acceleration) or full flow to zero (deceleration) is a net function of spool porting, orifices, and charge pressure. A swashplate response table is available for each frame indicating available swashplate response times. Testing should be conducted to verify the proper orifice selection for the desired response.

H1 pumps are limited in mechanical orificing combinations. Mechanical servo orifices are to be used only for fail-safe return to neutral in the event of an electrical failure.

Typical response times at the following conditions:

Δp	250 bar [3626 psi]
Viscosity and temperature	30 mm ² /s [141 SUS] and 50 °C [122 °F]
Charge pressure	20 bar [290 psi]
Speed	1800 min ⁻¹ (rpm)

Response time, FDC 045/053

Stroking direction	0.8 mm [0.03 in] Orifice
Full flow to neutral	1.9 s
Full forward flow to full reverse flow	2.8 s

Control Options

Manual Over Ride (MOR)

All controls are available with a Manual Over Ride (MOR) either standard or as an option for temporary actuation of the control to aid in diagnostics.

Forward-Neutral-Reverse (FNR) and Non Feedback Proportional Electric (NFPE) controls are always supplied with MOR functionality.

Manual OverRide (MOR)

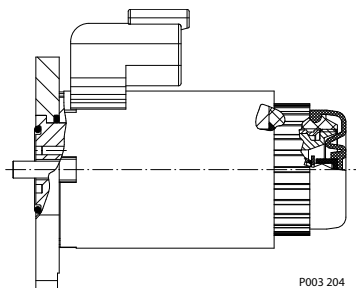

MOR schematic diagram (EDC shown)

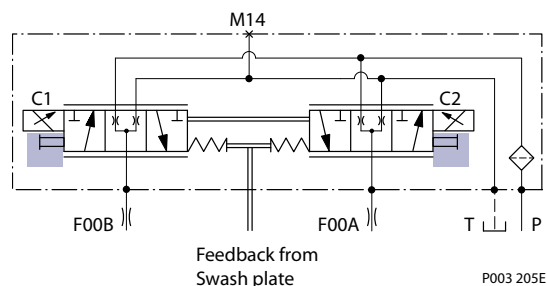

Unintended MOR operation will cause the pump to go into stroke. The vehicle or device must always be in a „safe“ condition (i.e. vehicle lifted off the ground) when using the MOR function.

The MOR plunger has a 4 mm diameter and must be manually depressed to be engaged. Depressing the plunger mechanically moves the control spool which allows the pump to go on stroke.

The MOR should be engaged anticipating a full stroke response from the pump.

Warning

An o-ring seal is used to seal the MOR plunger where initial actuation of the function will require a force of 45 N to engage the plunger. Additional actuations typically require less force to engage the MOR plunger. Proportional control of the pump using the MOR should not be expected.

Refer to control flow table for the relationship of solenoid to direction of flow.

Control Options

Swash plate angle sensor for NFPE and AC2 controls

The angle sensor detects the swash plate angle position and direction of rotation from the zero position. The swash angle sensor works on the AMR sensing technology. Under the saturated magnetic field, the resistance of the element varies with the magnetic field direction. The output signal give a linear output voltage for the various magnet positions in the sensing range. The swashplate angle sensor is available for all NFPE and AC2 controls.

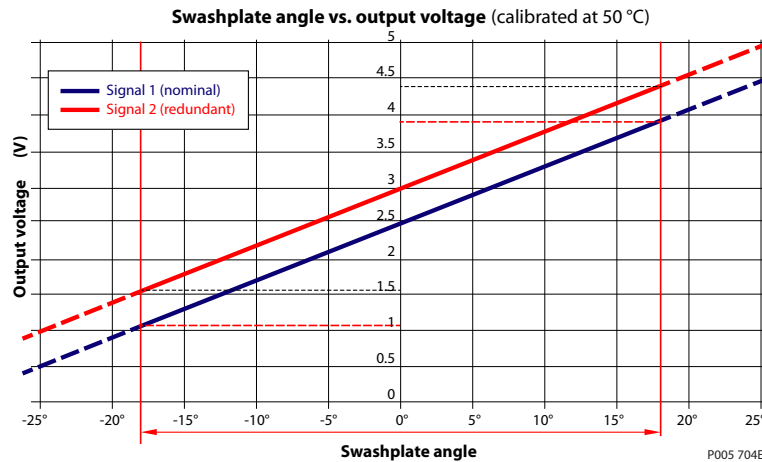
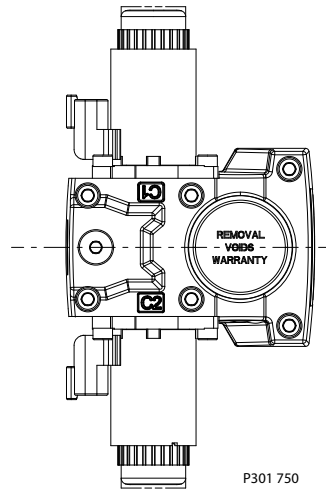

Swash Plate Angle Sensor Parameters

Parameter	Minimum	Typical	Maximum
Supply voltage range	4.75 V	5 V	5.25 V
Supply protection	–	–	28 V
Supply current	–	22 mA	25 mA
Output current (Signal 1, 2)	–	0.1 mA	–
Short circuit output current to supply or GND ¹⁾	–	–	7.5 mA
Sensitivity	70.0 mV/deg	78.0 mV/deg	85.8 mV/deg
Working range (swashplate angle)	–18°C	0°C	18°C
Correlation between signals 1 and 2 ²⁾	475 mV	500 mV	525 mV

¹⁾ Up to duration of 2.5 seconds at 25°C

²⁾ Signal 1 (nominal) is lower than signal 2 (redundant)

Control Options

Swash plate angle sensor connector

Pin assignment

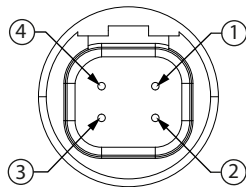

1. Ground (GND)
2. Output Signal 2 (SIG2) – Secondary (redundant)
3. Output Signal 1 (SIG1) – Primary (nominal)
4. Supply (V+)

Swash angle sensor connector order numbers

Description	Quantity	Ordering number
Mating connector DEUTSCH DTM06-4S-E004	1	11105824
Wedge lock DEUTSCH W4S	1	11084558
Socket contact (16-18 AWG)DEUTSCH 0462-201-16141	2	K02325

Interface with ECU

Interface with ECU schematic

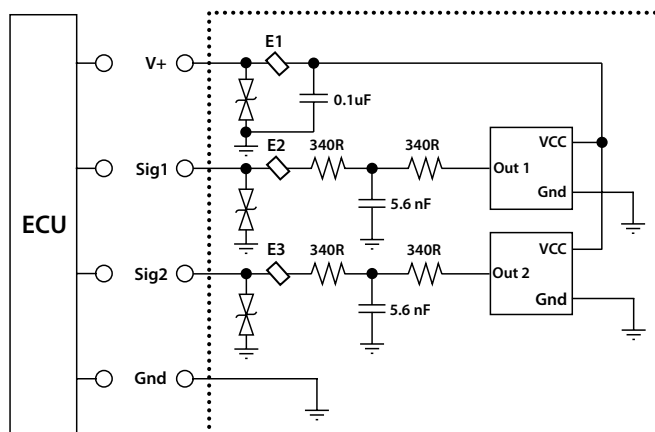

Minimum recommended load resistance is 100 kΩ.

Control Options

Control-Cut-Off valve (CCO valve)

The H1 pump offers an optional control cut off valve integrated into the control. This valve will block charge pressure to the control, allowing the servo springs to de-stroke both pumps regardless of the pump's primary control input. There is also a hydraulic logic port, X7, which can be used to control other machine functions, such as spring applied pressure release brakes. The pressure at X7 is controlled by the control cut off solenoid. The X7 port would remain plugged if not needed.

In the normal (de-energized) state of the solenoid charge flow is prevented from reaching the controls. At the same time the control passages and the X7 logic port are connected and drained to the pump case. The pump will remain in neutral, or return to neutral, independent of the control input signal. Return to neutral time will be dependent on oil viscosity, pump speed, swashplate angle, and system pressure.

When the solenoid is energized, charge flow and pressure is allowed to reach the pump control. The X7 logic port will also be connected to charge pressure and flow.

The solenoid control is intended to be independent of the primary pump control making the control cut off an override control feature. It is however recommended that the control logic of the CCO valve be maintained such that the primary pump control signal is also disabled whenever the CCO valve is de-energized. Other control logic conditions may also be considered.

All EDC and MDC controls are available with a CCO valve. The CCO-valve is available with 12 V or 24 V solenoid.

The response time of the unit depends on the control type and the used control orifices.

CCO schematic (MDC shown)

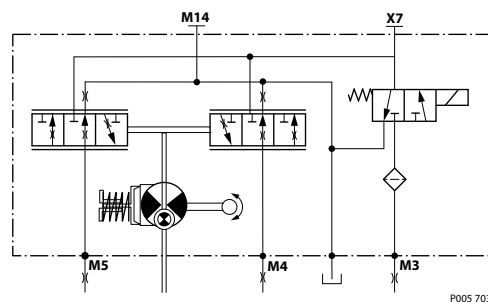

CCO connector

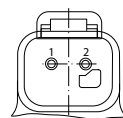

Connector ordering data

Description	Quantity	Ordering number
Mating connector	1	DEUTSCH DT06-2S
Wedge lock	1	DEUTSCH W2S
Socket contact (16 and 18 AWG)	2	DEUTSCH 0462-201-16141

CCO solenoid data

Nominal supply voltage		12 V	24 V
Supply voltage	Maximum	14.6 V	29 V
	Minimum	9.5 V	19 V
Nominal coil resistance at 20°C		10.7 Ω	41.7 Ω

Control Options

Nominal supply voltage		12 V	24 V
Supply current	Maximum	850 mA	430 mA
	Minimum	580 mA	300 mA
PWM frequency	Range	50-200 Hz	50-200 Hz
	Preferred	100 Hz	100 Hz
Electrical protection class		IP67 / IP69K with mating connector	
Bi-directional diode cut off voltage		28 V	53 V

Brake gauge port with MDC

 **Caution**

It is not recommended to use brake port for any external flow consumption to avoid malfunction of CCO function.

Control Options

Displacement limiter

H1 pumps are designed with optional mechanical displacement (stroke) limiters factory set to max. displacement. The maximum displacement of the pump can be set independently for forward and reverse using the two adjustment screws to mechanically limit the travel of the servo piston down to 50 % displacement.

Adjustments under operating conditions may cause leakage. The adjustment screw can be completely removed from the threaded bore if backed out to far.

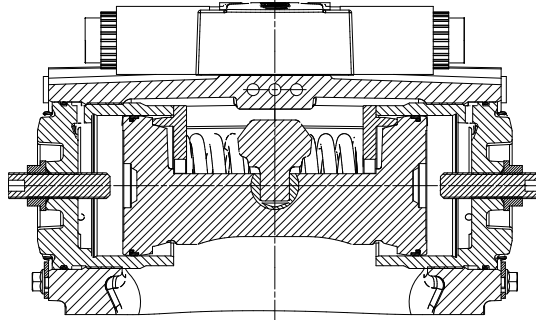

P003 266

Displacement change (approximately) H1P 045/053 Single

Parameter	Size 045	Size 053
1 Turn of displacement limiter screw	5.1 cm ³ [0.31 in ³]	6.0 cm ³ [0.37 in ³]
Internal wrench size	4 mm	
External wrench size	13 mm	
Torque for external hex seal lock nut	23 N·m [204 lbf·in]	

For more information, see *H1 Axial Piston Pumps, Service Manual*, **AX00000087**, the section "Displacement Limiter Adjustment".

Dimensions

H1P input shaft, Option G4 (SAE B, 13 teeth)

Option G4, ISO 3019-1, Flange Outer dia 22 mm-4 (SAE B, 13 Teeth)

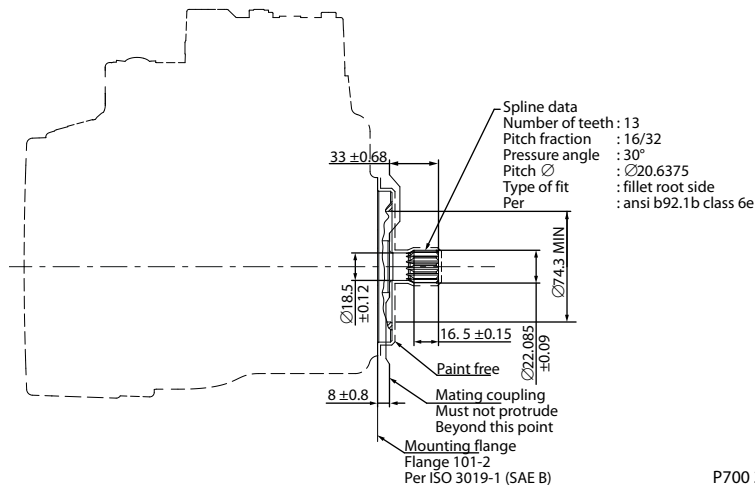

Specifications

Option	G4	
Spline	13 teeth, 16/32 pitch	
Min. active spline length¹⁾	16.5 mm [0.65 in]	
Torque rating²⁾	Rated	180 N•m [1600 lbf•in]
	Maximum	222 N•m [1970 lbf•in]

¹⁾ Minimum active spline length for the specified torque ratings.

²⁾ For definitions of maximum and rated torque values, refer to *Basic Information 11062168*, section Shaft Torque Ratings and Spline Lubrication.

Dimensions

H1P input shaft, option G1 (SAE B, 14 teeth)

Option G1, ISO 3019-1, Outer dia 32 mm-4 (SAE B, 14 Teeth)

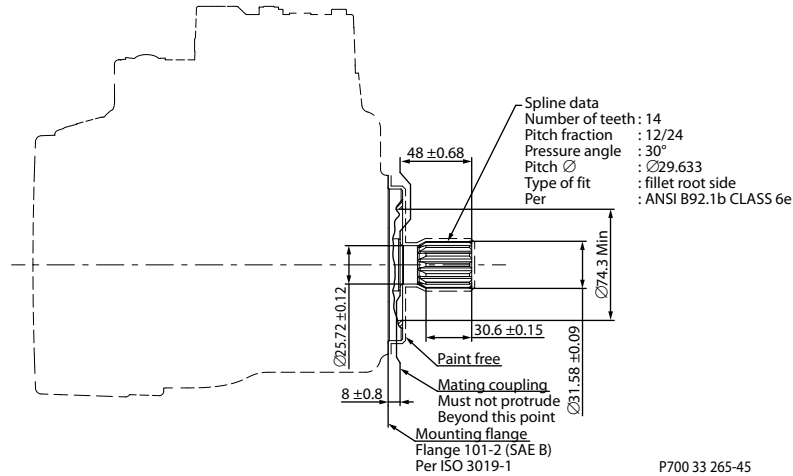

Specifications

Option	G1	
Spline	14 teeth, 12/24 pitch	
Min. active spline length¹⁾	30.6 mm [1.205 in]	
Torque rating²⁾	Rated	534 N•m [4720 lbf•in]
	Maximum	592 N•m [5240 lbf•in]

¹⁾ Minimum active spline length for the specified torque ratings.

²⁾ For definitions of maximum and rated torque values, refer to *Basic Information 11062168*, section Shaft Torque Ratings and Spline Lubrication.

Dimensions

H1P input shaft, option G5 (SAE B-B, 15 teeth)

Option G5, ISO 3019-1, Flange Outer dia 25 mm-4 (SAE B-B, 15 Teeth)

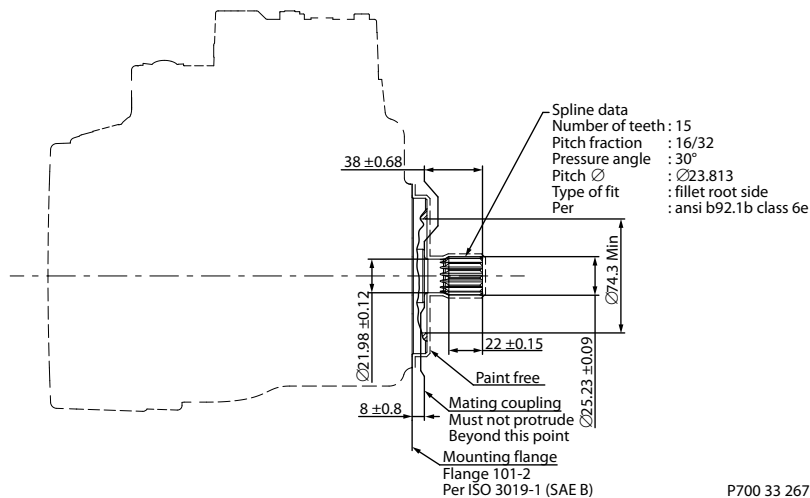

Specifications

Option	G5	
Spline	15 teeth, 16/32 pitch	
Min. active spline length¹⁾	22 mm [0.866 in]	
Torque rating²⁾	Rated	277 N•m [2450 lbf•in]
	Maximum	370 N•m [3270 lbf•in]

¹⁾ Minimum active spline length for the specified torque ratings.

²⁾ For definitions of maximum and rated torque values, refer to *Basic Information 11062168*, section Shaft Torque Ratings and Spline Lubrication.

Dimensions

H1P input shaft, option F2, Code 25-3

Option F2, ISO 3019-1, Code 25-3, Dia 25.4 Taper 1:8, without key, no through-hole in the end of the shaft

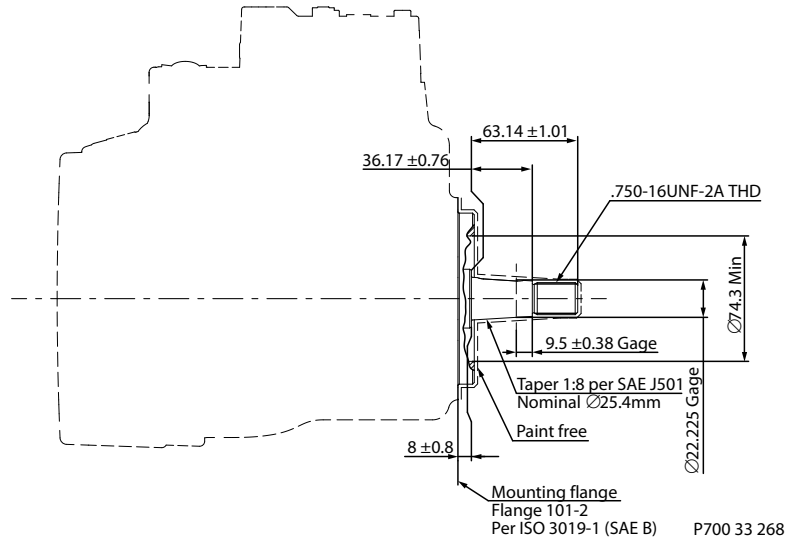

Specifications

Option		F2
Tapered shaft ¹⁾		25.4 taper without key
Torque rating ²⁾	Rated ³⁾	405 N·m [3580 lbf·in]
	Maximum	540 N·m [4780 lbf·in]

¹⁾ Mating part must maintain a minimum gap width of 1.0 mm with the shaft shoulder after installation of the part. Transmittable torque will be reduced if the minimum gap requirement is not met.

²⁾ For definitions of maximum and rated torque values, refer to *Basic Information 11062168*, section Shaft Torque Ratings and Spline Lubrication.

³⁾ Rated torque includes just the capability of the press-fit in accordance with an assumed fastener grade 5.

Tapered shaft customer acknowledgement

The Danfoss H1 tapered shaft has been designed using the industry standard ISO 3019-1, minus the through-hole in the end of the shaft. Danfoss recommends a self-locking nut instead of a castle nut and pin. The nut and mating square-cut key are customer supplied. The specified torque rating of the tapered shaft is based on the cross-sectional diameter of the shaft, through the keyway, and assumes the proper clamp and fit between shaft and coupling.

Danfoss guarantees the design and manufactured quality of the tapered shaft. The customer is responsible for the design and manufactured quality of the mating female coupling and key and applied torque on the nut. Danfoss has made provisions for the key in accordance to the ISO specification with the understanding that the key is solely to assist in the installation of the mating coupling.

⚠ Caution

Possible hazard because torque or loading inadvertently transmitted by the customer supplied key may lead to premature shaft failure.

Torque must be transmitted by the taper fit between the shaft and it's mating coupling, not the key.

Dimensions

H1P Auxiliary mounting, option H2 (SAE A, 9 teeth)

Option H2, ISO 3019-1, flange 82-2 (SAE A, 9 teeth)

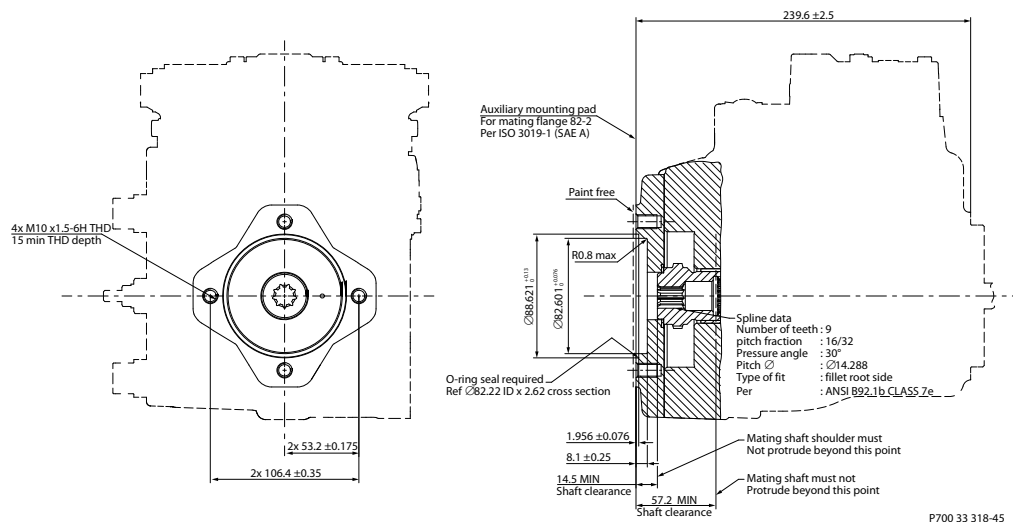

Specifications

Option	H2
Spline	9 teeth, 16/32 pitch
Maximum torque¹⁾	162 N·m [1430 lbf·in]

¹⁾ For definitions of maximum and rated torque values, refer to *Basic Information 11062168*, section Shaft Torque Ratings and Spline Lubrication.

⚠ Caution

Standard pad cover is installed only to retain coupling during shipping. Do not operate pump without an auxiliary pump or running cover installed.

H1P Auxiliary mounting, option H1 (SAE A, 11 teeth)

Option H1, ISO 3019-1, Flange 82-2 (SAE A, 11 Teeth)

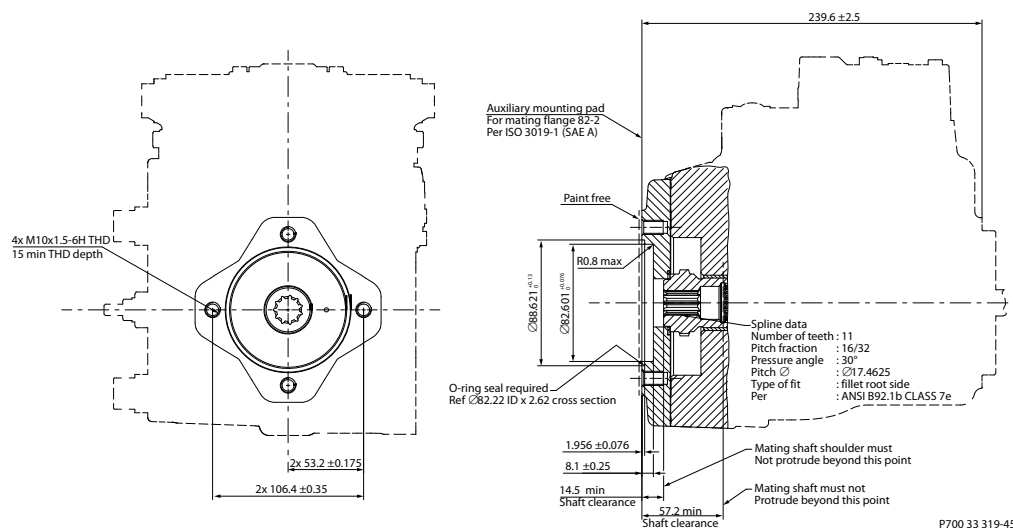

Dimensions

Specifications

Option	H1
Spline	11 teeth, 16/32 pitch
Maximum torque¹⁾	296 N·m [2620 lbf·in]

¹⁾ For definitions of maximum and rated torque values, refer to *Basic Information 11062168*, section Shaft Torque Ratings and Spline Lubrication.

Caution

Standard pad cover is installed only to retain coupling during shipping. Do not operate pump without an auxiliary pump or running cover installed.

H1P Auxiliary mounting, option H3 (SAE B, 13 teeth)

Option H3, ISO 3019-1, flange 101-2 (SAE B, 13 teeth)

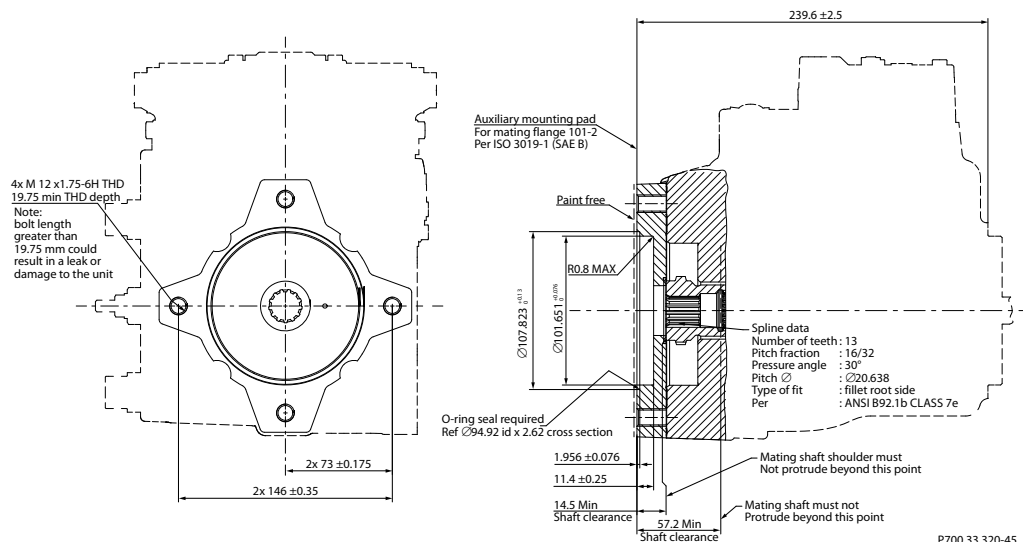

Specifications

Option	H3
Spline	13 teeth, 16/32 pitch
Maximum torque¹⁾	395 N·m [3500 lbf·in]

¹⁾ For definitions of maximum and rated torque values, refer to *Basic Information 11062168*, section Shaft Torque Ratings and Spline Lubrication.

Caution

Standard pad cover is installed only to retain coupling during shipping. Do not operate pump without an auxiliary pump or running cover installed.

Dimensions

H1P Auxiliary mounting, option H5 (SAE B-B, 15 teeth)

Option H5, ISO 3019-1, flange 101-2 (SAE B-B, 15 teeth)

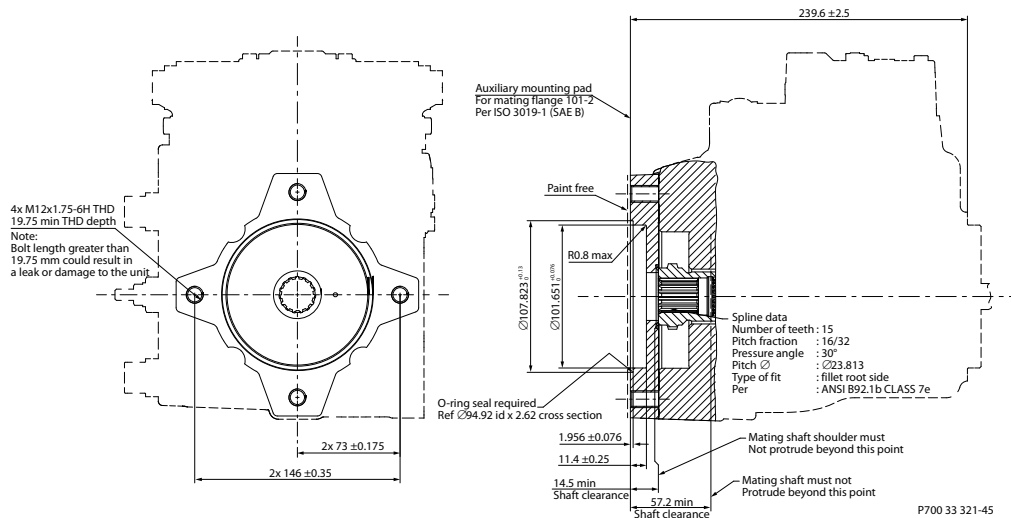

Specifications

Option	H5
Spline	15 teeth, 16/32 pitch
Maximum torque ¹⁾	405 N·m [3580 lbf·in]

¹⁾ For definitions of maximum and rated torque values, refer to *Basic Information 11062168*, section Shaft Torque Ratings and Spline Lubrication.

⚠ Caution

Standard pad cover is installed only to retain coupling during shipping. Do not operate pump without an auxiliary pump or running cover installed.

H1P displacement limiter, 045/053 Single, option B and D

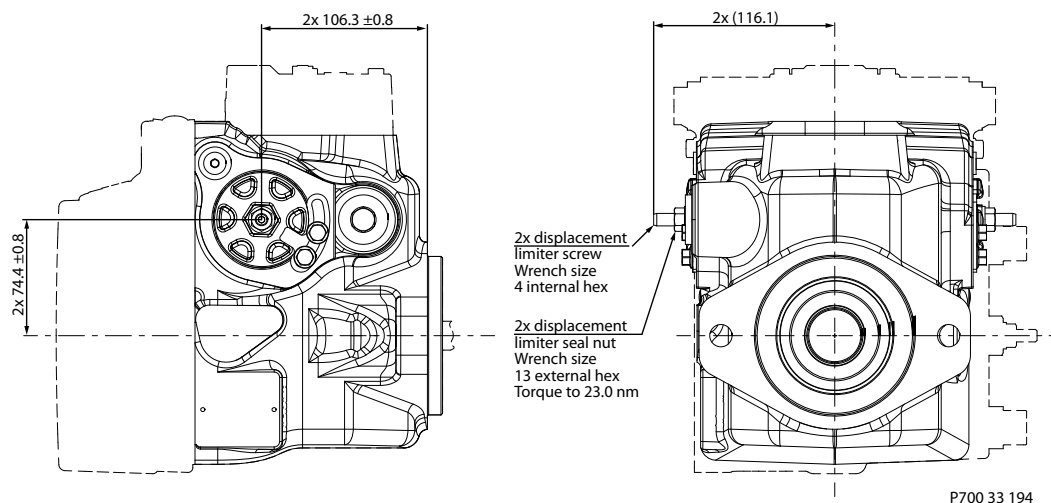

Please contact Danfoss representative for specific installation drawings.

Dimensions

H1P endcap, twin port, Code 62, metric 4 bold FLG, 045/053 S, option D6, D8, F2, and F3

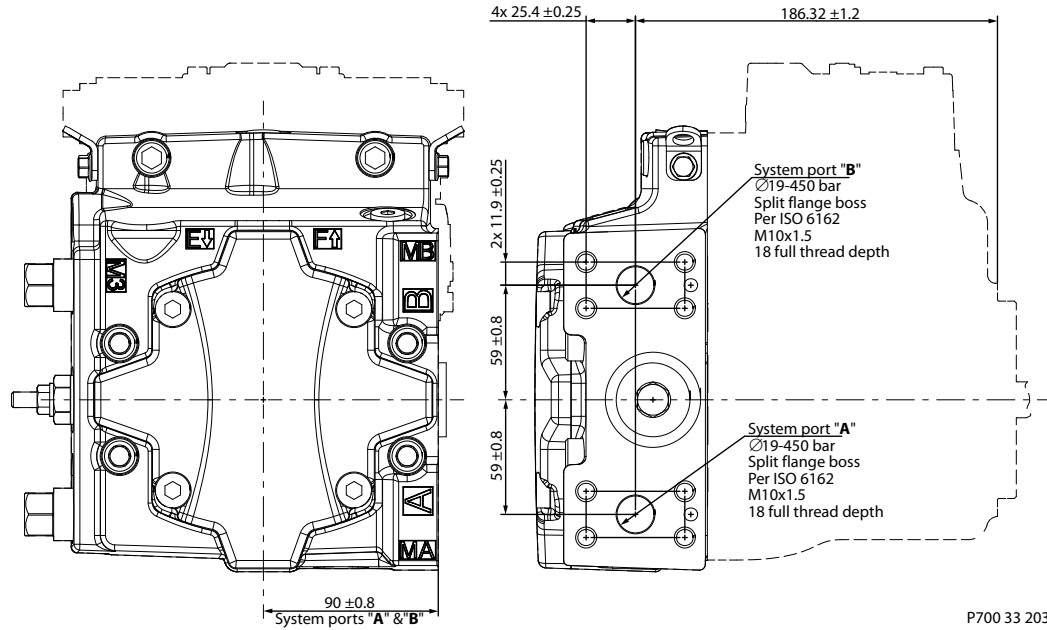

P700 33 203

Please contact Danfoss representative for specific installation drawings.

Speed and temperature sensor, option H (for mounting flange option K)

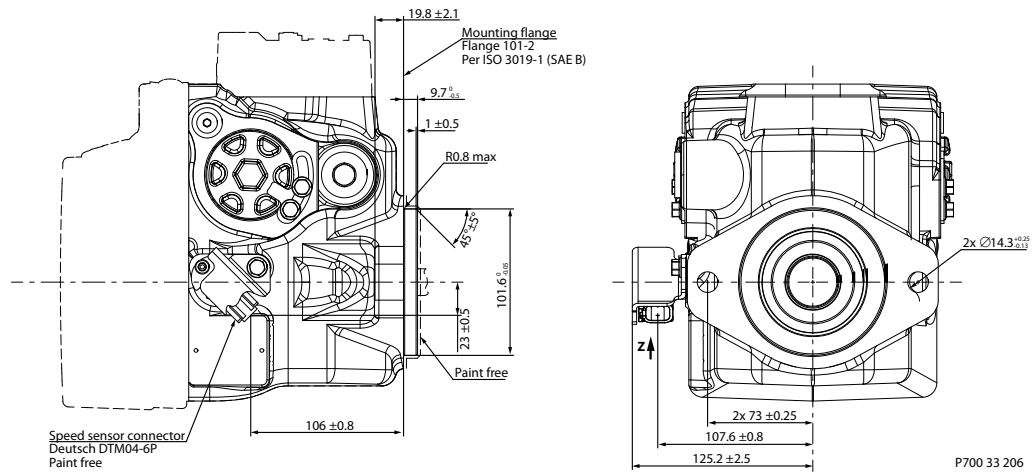

P700 33 206

Z (2:1)

Speed sensor Connector	
PIN	ASSIGNMENT
1	Output signal 2
2	Direction
3	Output signal 1
4	Supply
5	Ground
6	Temperature

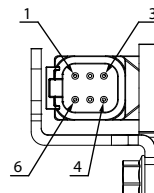

P301 310

Please contact Danfoss representative for specific installation drawings.

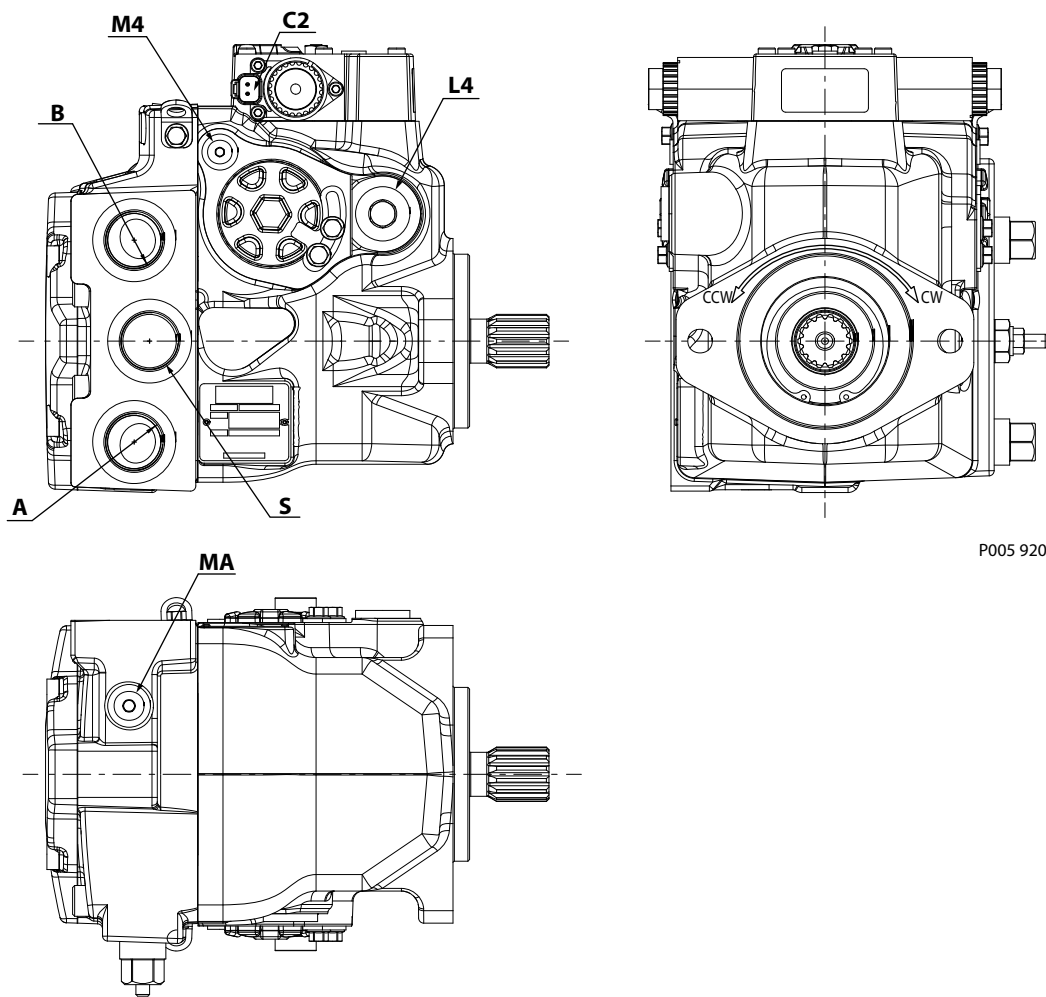
Installation drawings
H1P single pump ports description

P005 920

Ports description (ports per ISO 11 926-1)

Port	Description	Size
A, B	System ports (Optional ports Ø19)	1 ⁵ / ₁₆ -12
E / F	Charge filtration ports (from filter / to filter)	7/ ₈ -14
L2, L4	Case drain ports	1 ¹ / ₁₆ -12
MA, MB	System gauge ports A / B	9/ ₁₆ -18
M3	Charge gauge port	9/ ₁₆ -18
AM3	Alternate charge pressure port	9/ ₁₆ -18
M4, M5	Servo gauge ports (Ø29 max clearance for fitting)	7/ ₁₆ -20
M14	Case gauge port (Ø21 max clearance for fitting); EDC, FNR, NFPE	7/ ₁₆ -20
S	Charge inlet port	1 ⁵ / ₁₆ -12

Please contact Danfoss representative for specific installation drawings.

Installation drawings

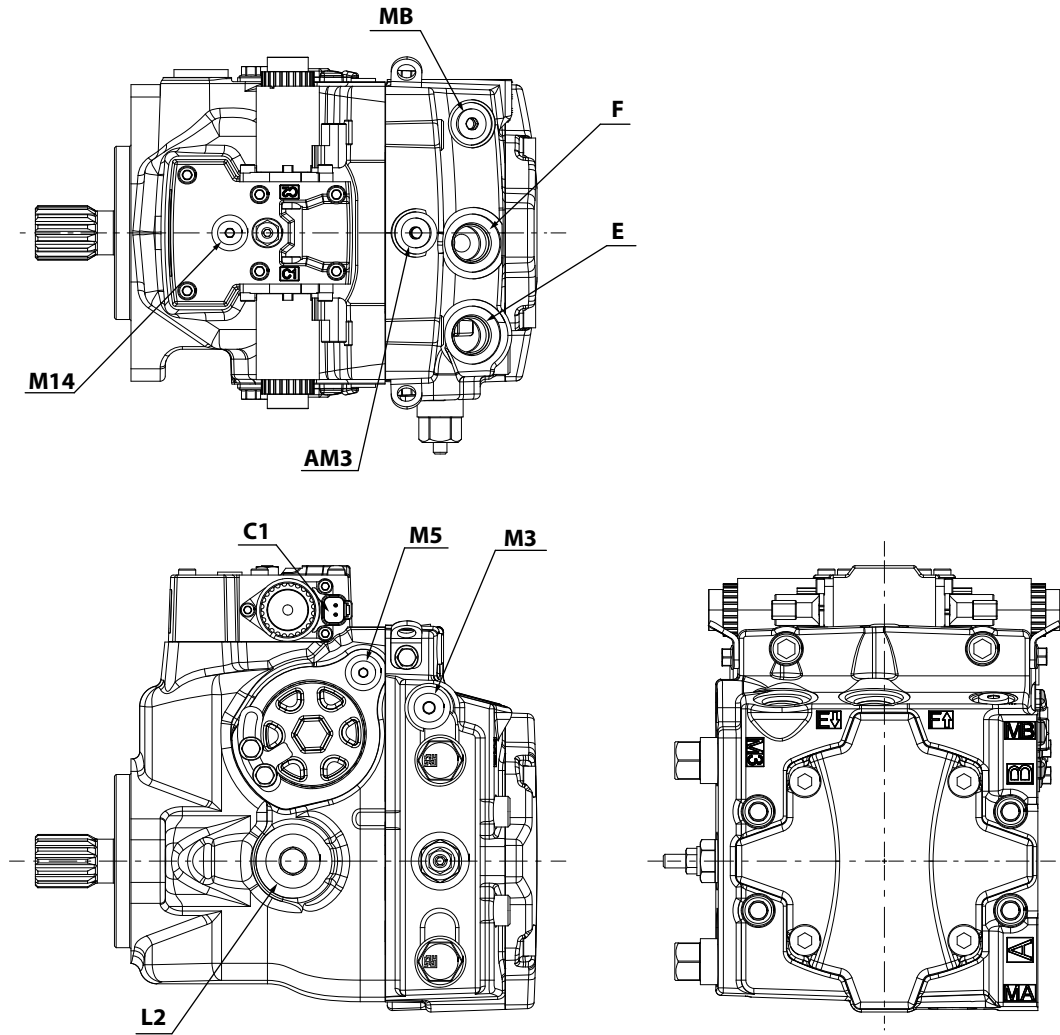

P005 921

Ports description (ports per ISO 11 926-1)

Port	Description	Size
A, B	System ports (Optional ports Ø19)	1 ⁵ / ₁₆ -12
E / F	Charge filtration ports (from filter / to filter)	7/ ₈ -14
L2, L4	Case drain ports	1 ¹ / ₁₆ -12
MA, MB	System gauge ports A / B	9/ ₁₆ -18
M3	Charge gauge port	9/ ₁₆ -18
AM3	Alternate charge pressure port	9/ ₁₆ -18
M4, M5	Servo gauge ports (Ø29 max clearance for fitting)	7/ ₁₆ -20
M14	Case gauge port (Ø21 max clearance for fitting); EDC, FNR, NFPE	7/ ₁₆ -20
S	Charge inlet port	1 ⁵ / ₁₆ -12

Please contact Danfoss representative for specific installation drawings.

Installation drawings

Dimensions H1P 045/053 Single

Twin Port, ORB, Remote Filter

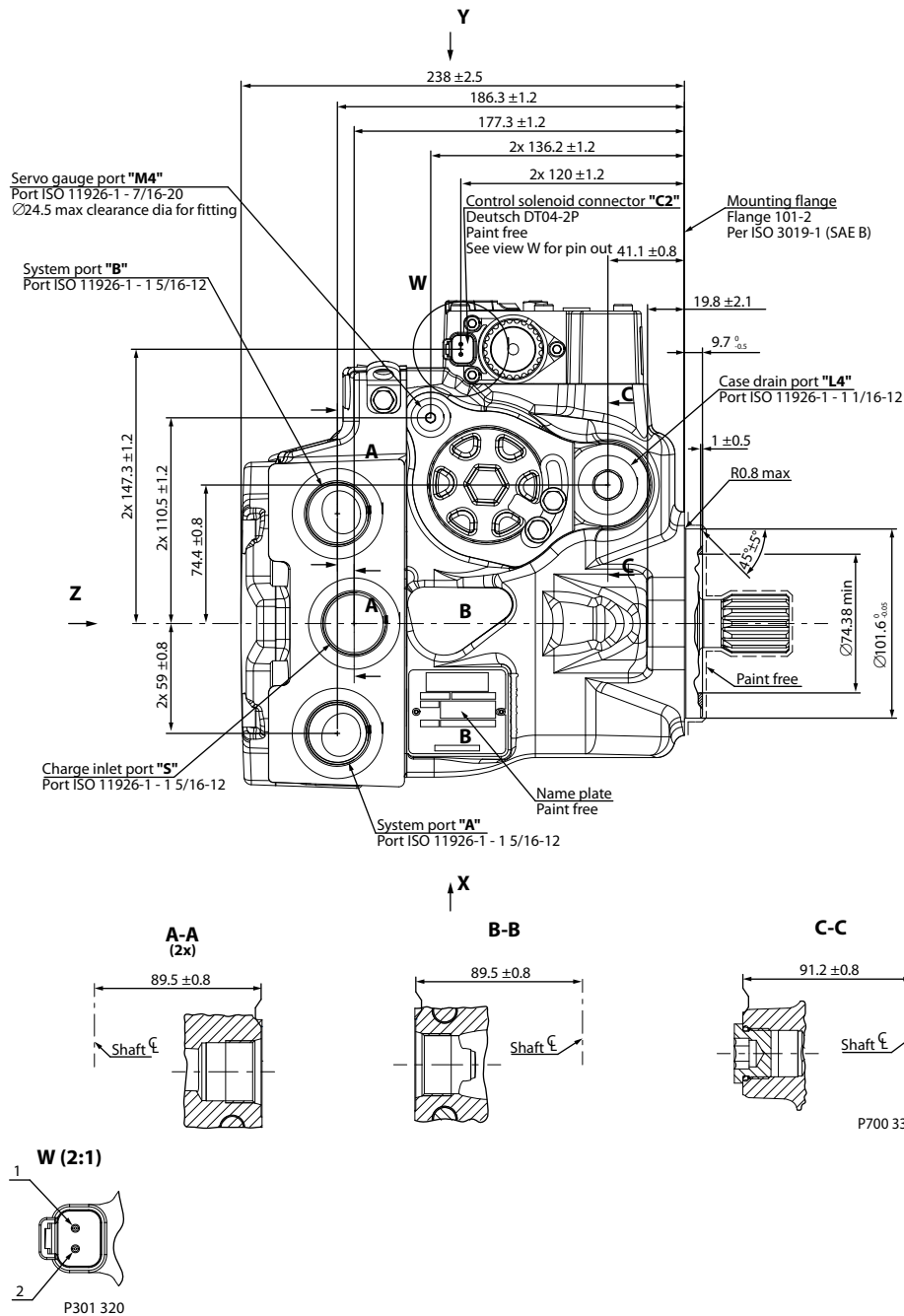

P700 33 051-1

Control solenoid Connector "C1" & "C2"				
Pin	Assignment	OR	Pin	Assignment
1	Supply			1
2	Ground		2	Supply

Please contact Danfoss representative for specific installation drawings.

Technical Information
H1 Axial Piston Single Pumps, Size 045/053

Installation drawings

Twin Port, ORB, Remote Filter

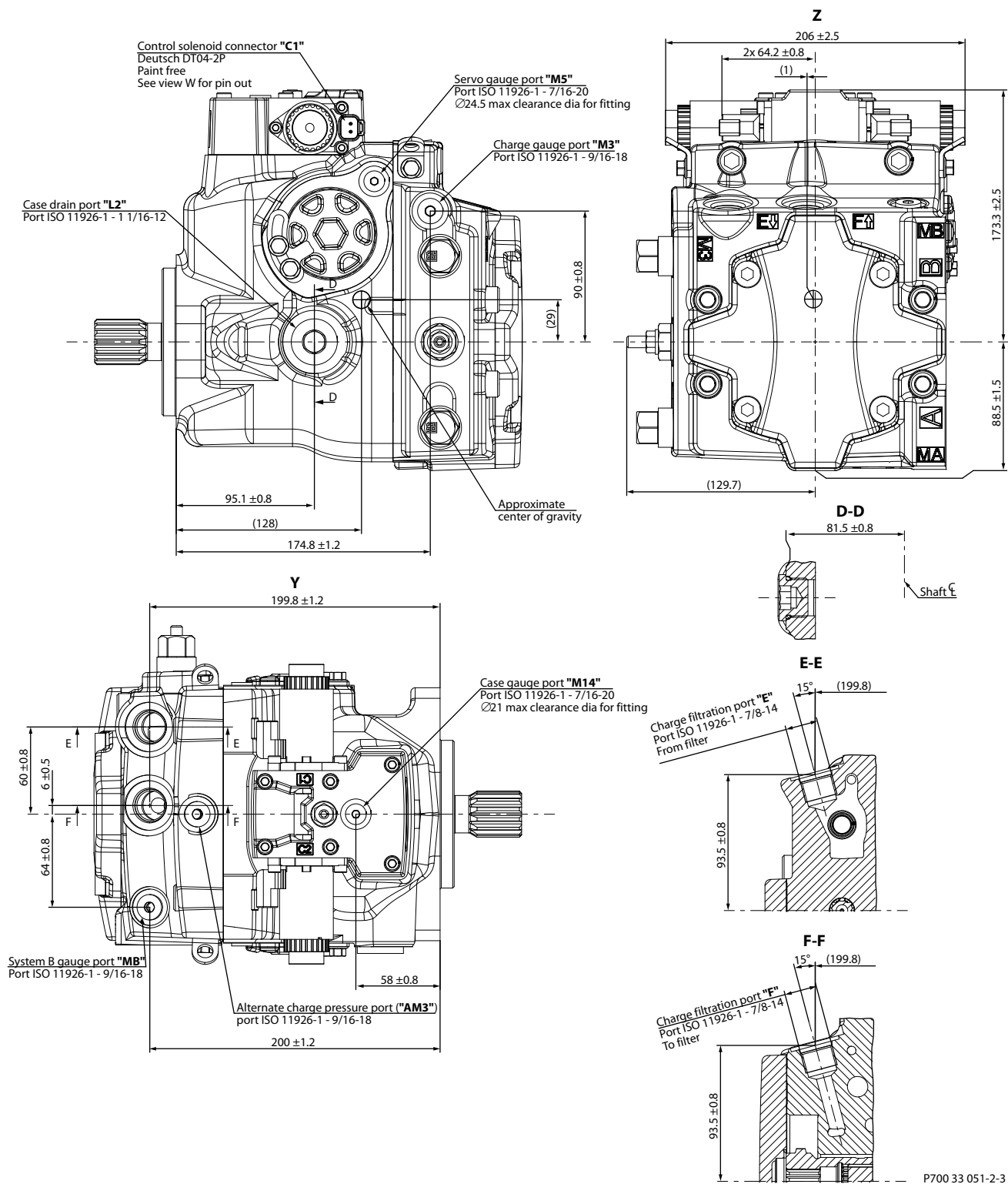

Please contact Danfoss representative for specific installation drawings.

Installation drawings

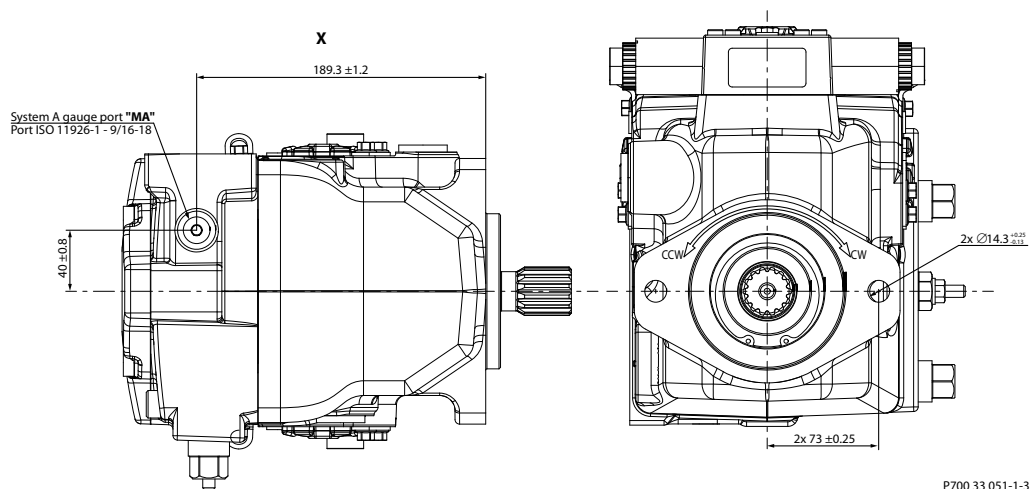

Please contact Danfoss representative for specific installation drawings.

Controls

Electric Displacement Control (EDC), option A2 (12V) / A3 (24V)

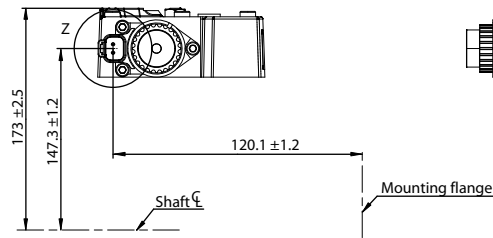
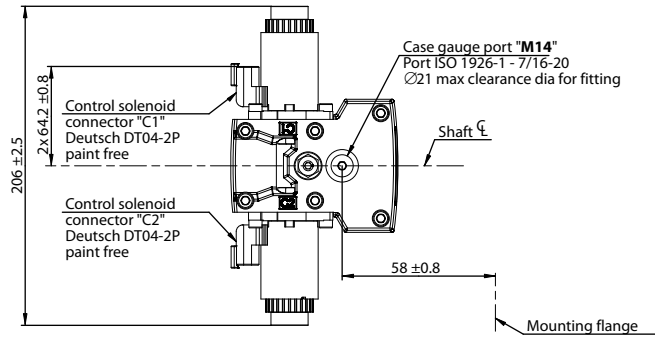

P700 332 58-45

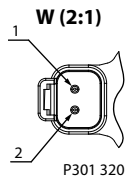

Control solenoid Connector "C1" & "C2"				
Pin	Assignment	OR	Pin	Assignment
1	Supply		1	Ground
2	Ground		2	Supply

Please contact Danfoss representative for specific installation drawings.

Controls

Electric Displacement Control (EDC) with MOR, option A4 (12 V) / A5 (24 V)

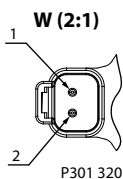
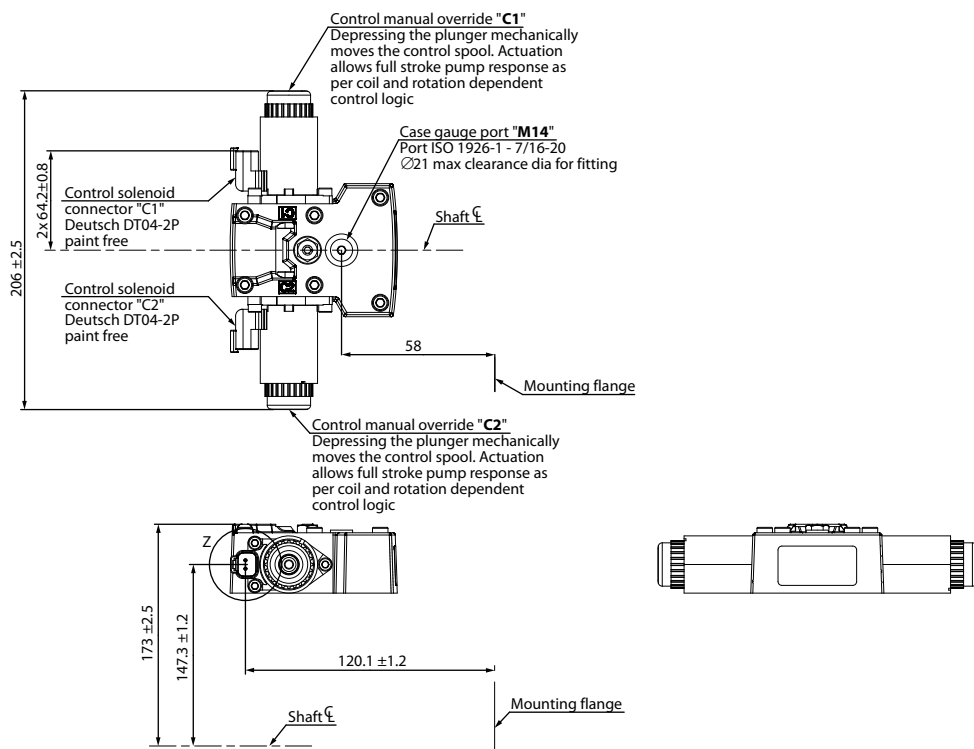

Control solenoid Connector "C1" & "C2"				
Pin	Assignment	OR	Pin	Assignment
1	Supply		1	Ground
2	Ground		2	Supply

Please contact Danfoss representative for specific installation drawings.

Controls

H1P 045/053 Manual Displacement Control (MDC), option M1

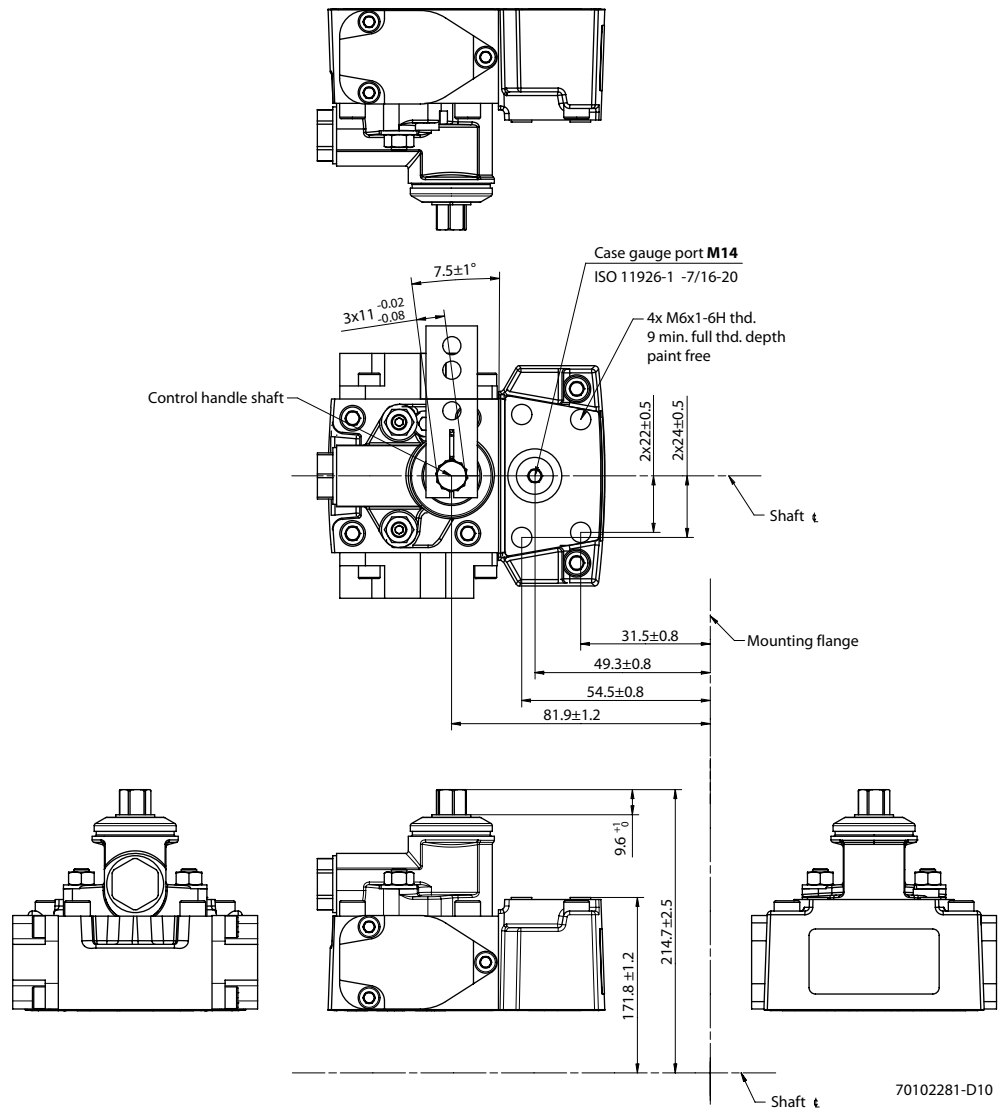

Please contact Danfoss representative for specific installation drawings.

Controls

H1P 045/053 Manual Displacement Control (MDC) with NSS, option M2

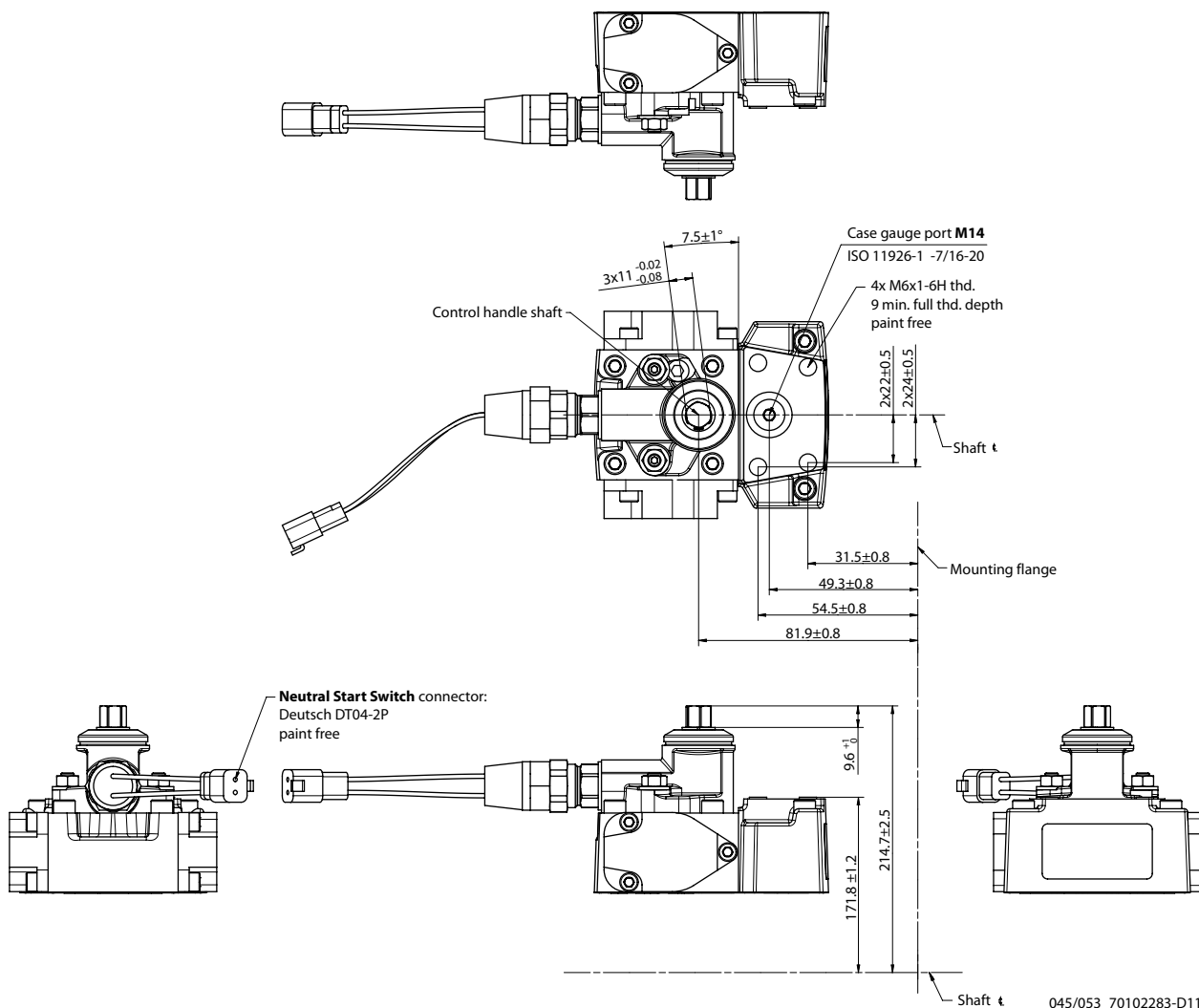

Neutral Start Switch connector:

Pin	Assignment		Pin	Assignment
1	Supply	OR	1	Ground
2	Ground		2	Supply

[Please contact Danfoss representative for specific installation drawings.](#)

Controls

H1P 045/053 Manual Displacement Control (MDC) with CCO, option M3, M4

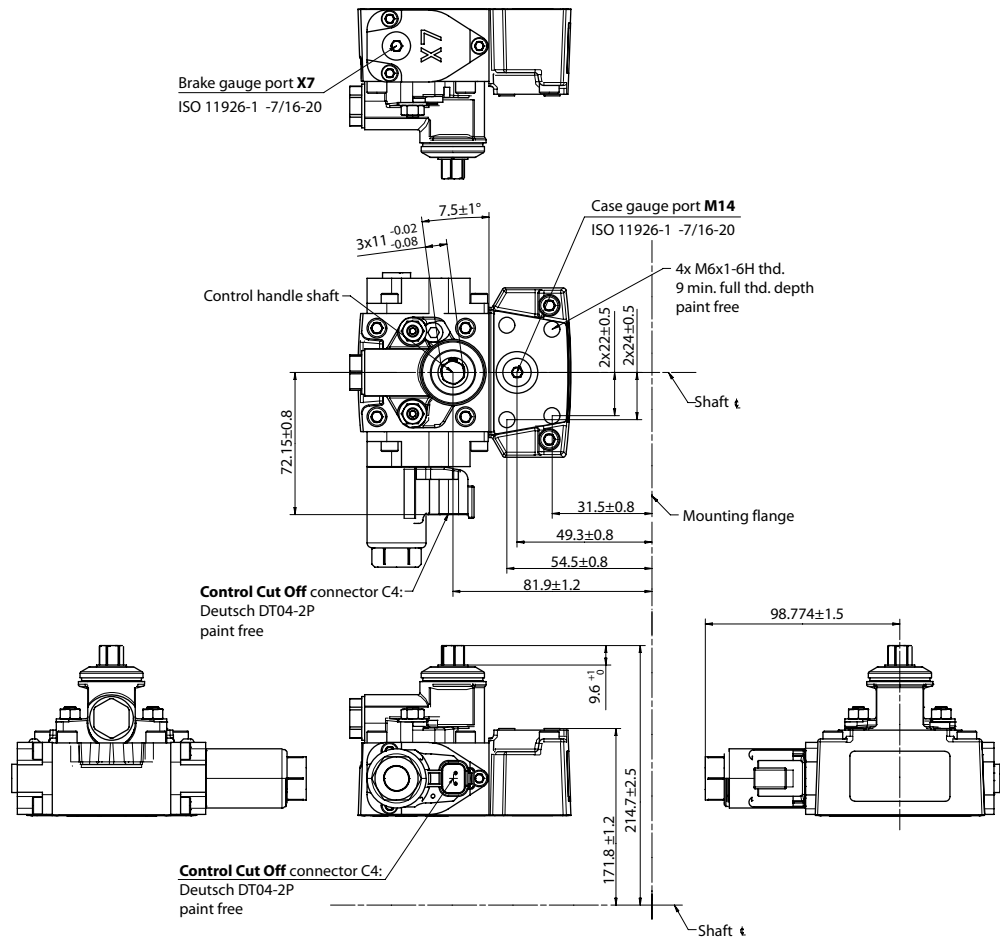

045/053_70102283-D12

Control Cut Off connector C4:

Pin	Assignment		Pin	Assignment
1	Supply	OR	1	Ground
2	Ground		2	Supply

[Please contact Danfoss representative for specific installation drawings.](#)

Controls

H1P 045/053 Manual Displacement Control (MDC) with NSS and CCO, option M5, M6

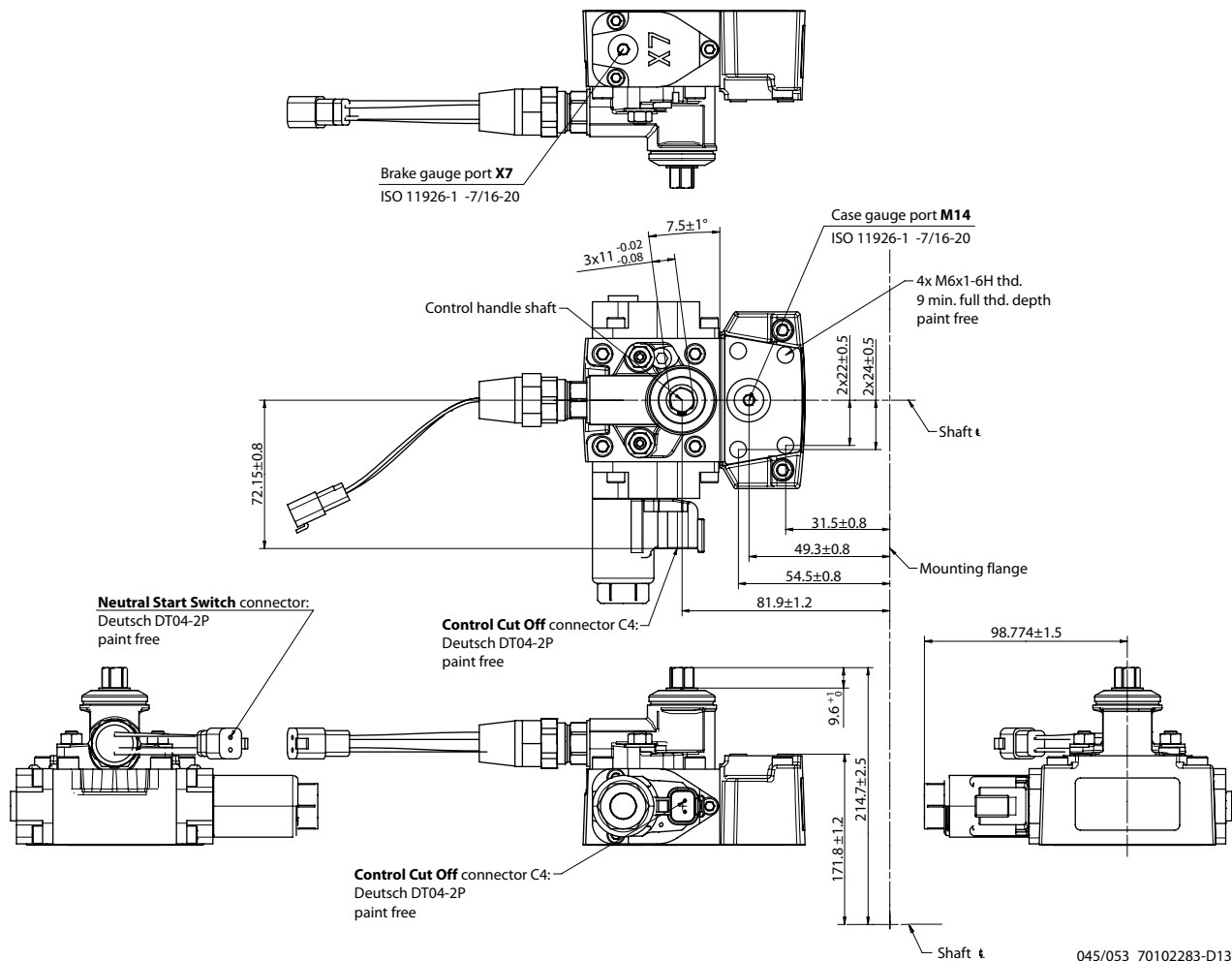

Neutral Start Switch connector / Control Cut Off connector C4:

Pin	Assignment		Pin	Assignment
1	Supply	OR	1	Ground
2	Ground		2	Supply

Please contact Danfoss representative for specific installation drawings.

Controls

Forward-Neutral-Reverse (FNR) with MOR, option A9 (12 V) B1 (24 V)

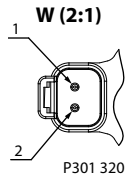
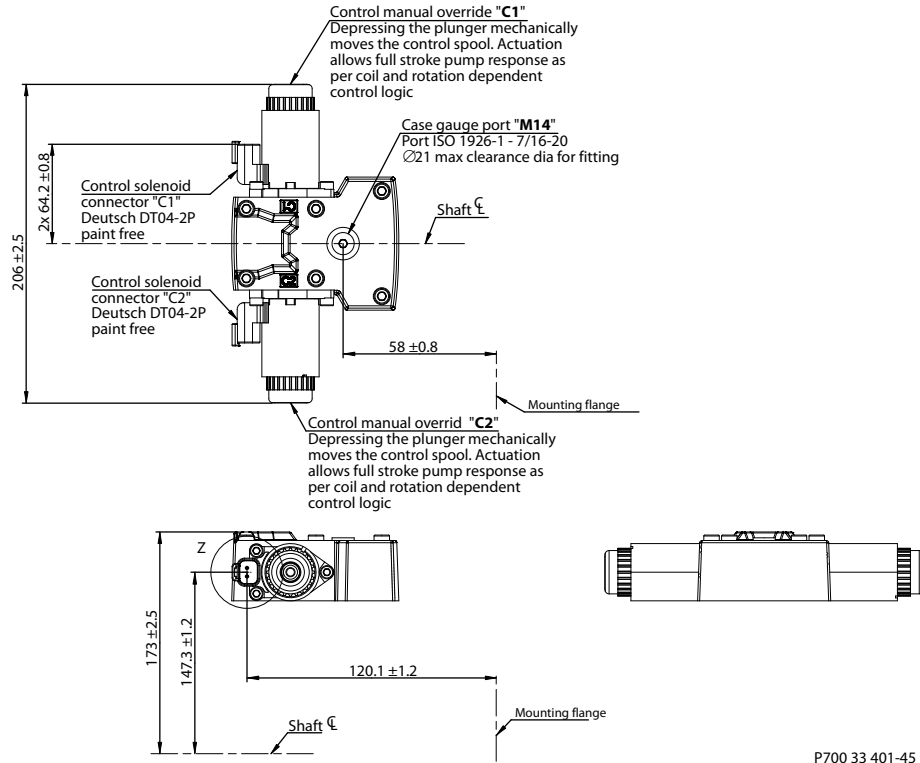

Control solenoid Connector "C1" & "C2"				
Pin	Assignment	OR	Pin	Assignment
1	Supply		1	Ground
2	Ground		2	Supply

Please contact Danfoss representative for specific installation drawings.

Controls

Non Feedback Proportional Electric Control (NFPE) with MOR, options: A8 (12 V) / B8 (24V)

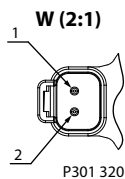
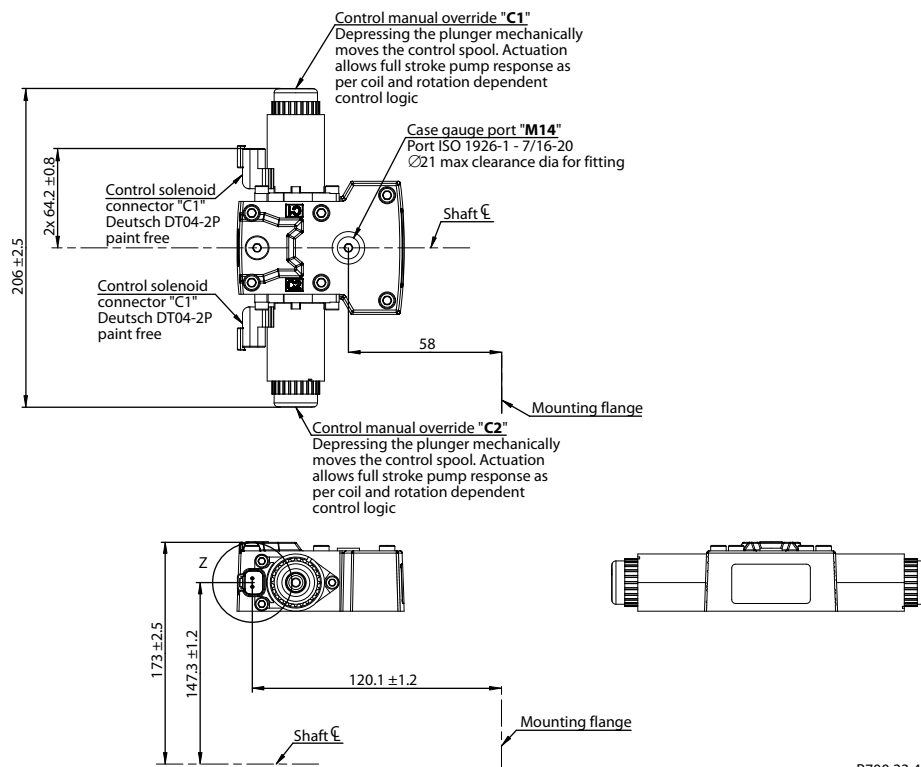

Control solenoid Connector "C1" & "C2"				
Pin	Assignment	OR	Pin	Assignment
1	Supply		1	Ground
2	Ground		2	Supply

Please contact Danfoss representative for specific installation drawings.

Controls

Automotive Control (AC) Dimensions

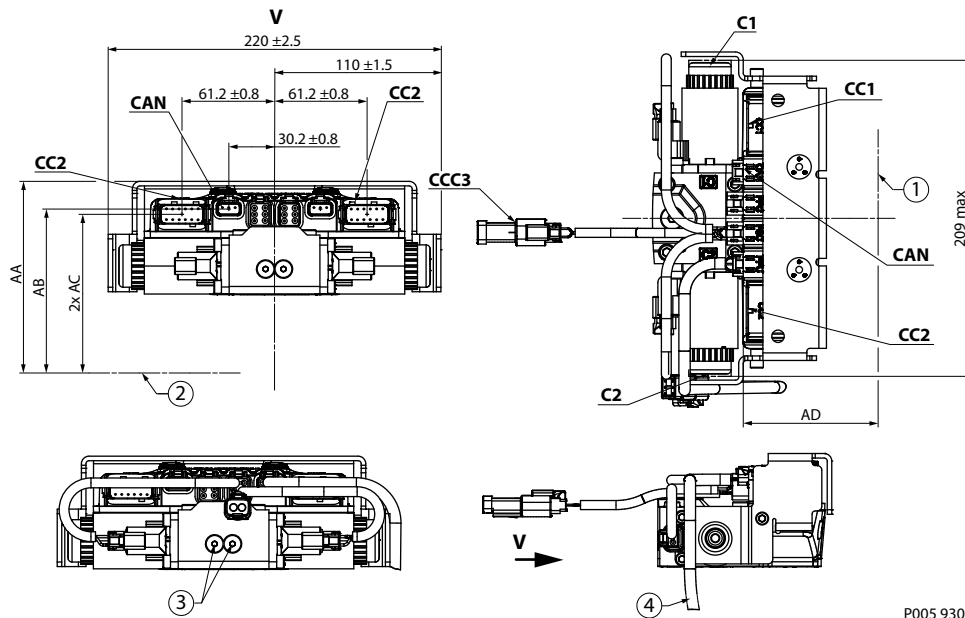

P005 930

1. Mounting flange
2. Shaft
3. Plug removing can cause contamination issues
4. PPU wire harness is factory installed to speed sensor

Dimensions, (mm)

Callout	Value
AA	208.9 ± 2.5
AB	190.5 ± 1.2
AC	2x 187.1 ± 1.2
AD	89.2 ± 1.2

Connectors description

Port	Description
C1 C2	Control MOR; Depressing the plunger mechanically moves the control spool. Actuation allows full stroke pump response as per coil and rotation dependent control logic.
CC1	Control connector Deutsch DTM04-12P -A; Paint free
CC2	Control connector Deutsch DTM04-12P -B; Paint free
CCC3	Control connector Deutsch DT06-2S; Paint free; For using connector the plug may be removed.
CAN	Control connector Deutsch DTM04-3P; Paint free; For using connector the plug may be removed.

Please contact Danfoss representative for specific installation drawings.

Controls

Fan Drive Control (FDC), option F1 (12V) / F2 (24V)

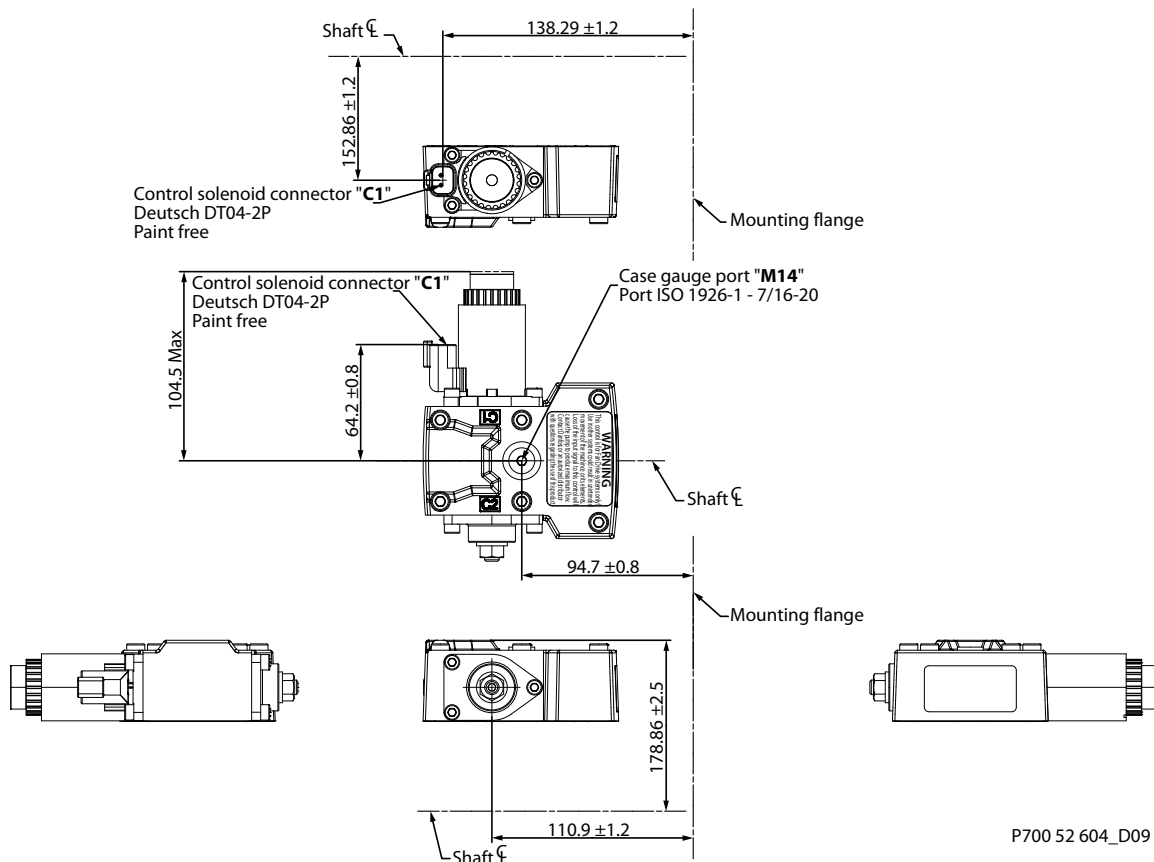

P700 52 604_D09

Control solenoid connector C1 and C2:

Pin	Assignment	Alternative	Pin	Assignment
1	Supply	OR	1	Ground
2	Ground		2	Supply

[Please contact Danfoss representative for specific installation drawings.](#)

Filtration

Suction filtration, option L for H1P 045/053 S

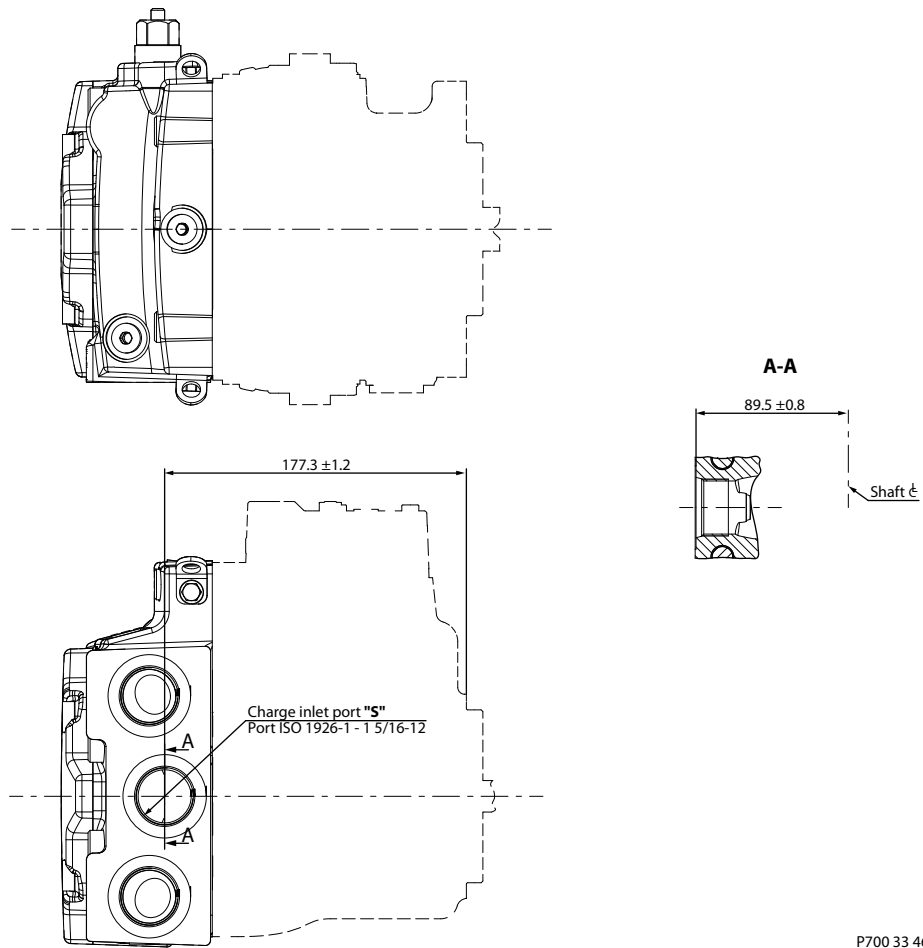

Please contact Danfoss representative for specific installation drawings.

Filtration

Remote full flow charge pressure filtration, option P for H1P 045/053 S (for endcap option F)

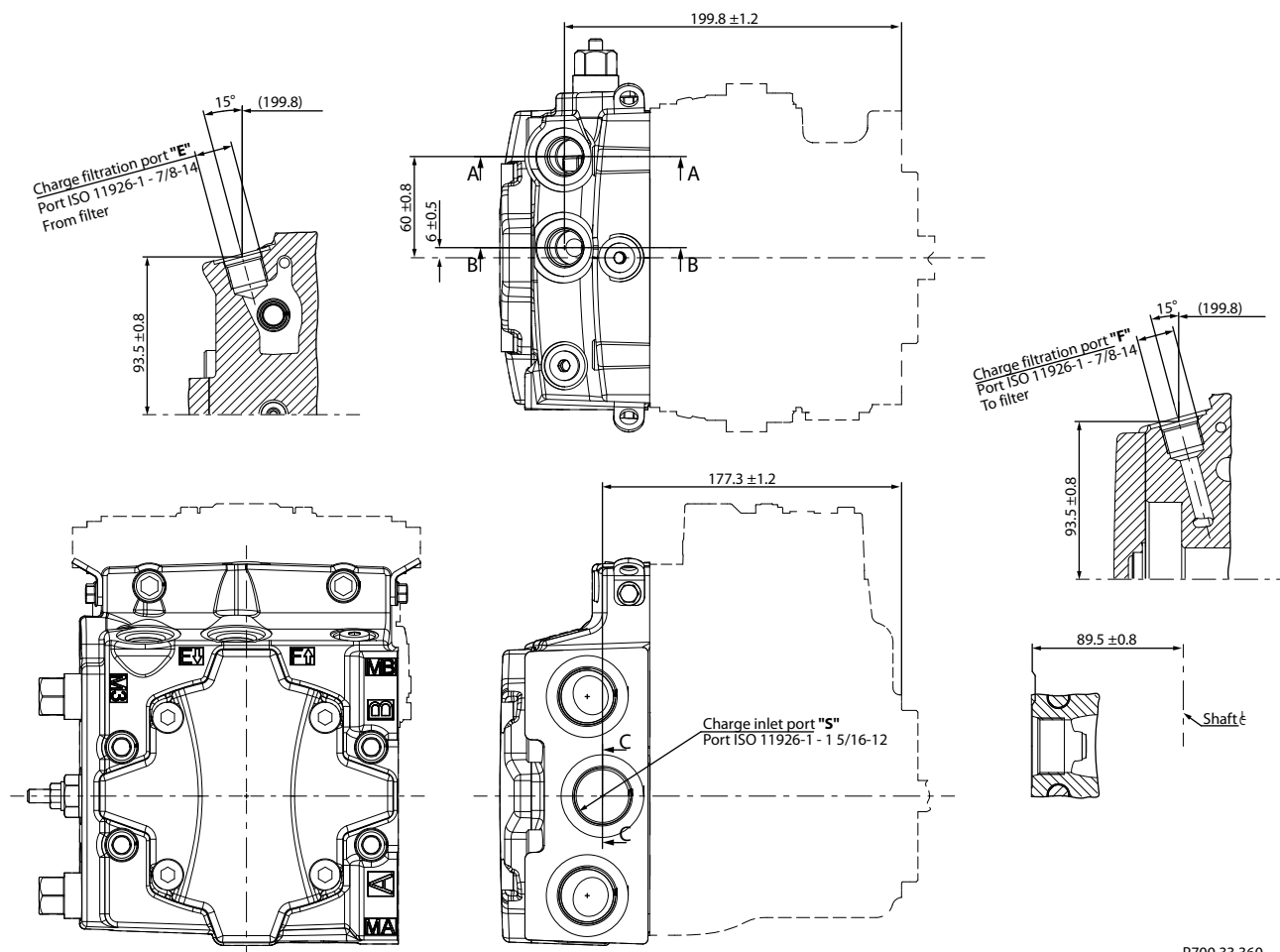

P700 33 360

Please contact Danfoss representative for specific installation drawings.

Filtration

External full flow charge pressure filtration, option E for H1P 045/053 S

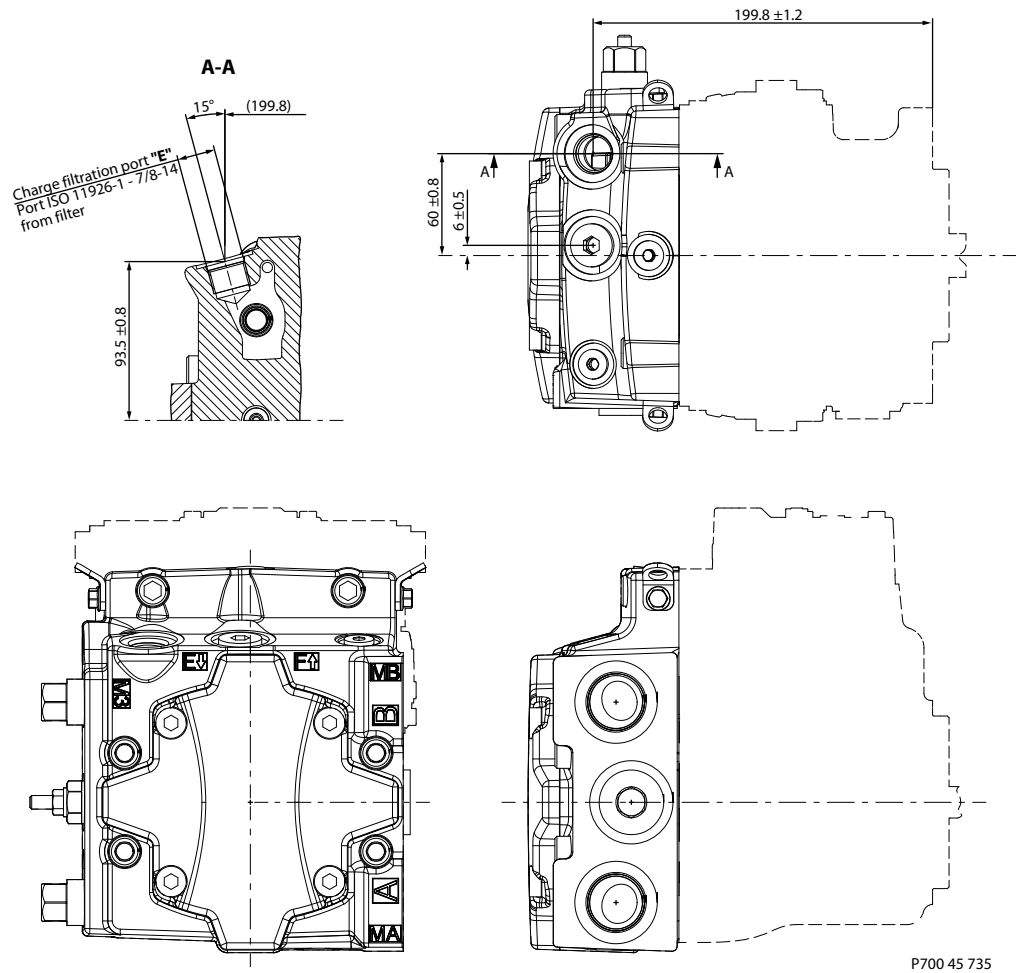

Please contact Danfoss representative for specific installation drawings.

Products we offer:

- Bent Axis Motors
- Closed Circuit Axial Piston Pumps and Motors
- Displays
- Electrohydraulic Power Steering
- Electrohydraulics
- Hydraulic Power Steering
- Integrated Systems
- Joysticks and Control Handles
- Microcontrollers and Software
- Open Circuit Axial Piston Pumps
- Orbital Motors
- PLUS+1® GUIDE
- Proportional Valves
- Sensors
- Steering
- Transit Mixer Drives

Danfoss Power Solutions is a global manufacturer and supplier of high-quality hydraulic and electronic components. We specialize in providing state-of-the-art technology and solutions that excel in the harsh operating conditions of the mobile off-highway market. Building on our extensive applications expertise, we work closely with our customers to ensure exceptional performance for a broad range of off-highway vehicles.

We help OEMs around the world speed up system development, reduce costs and bring vehicles to market faster.

Danfoss – Your Strongest Partner in Mobile Hydraulics.

Go to www.powersolutions.danfoss.com for further product information.

Wherever off-highway vehicles are at work, so is Danfoss. We offer expert worldwide support for our customers, ensuring the best possible solutions for outstanding performance. And with an extensive network of Global Service Partners, we also provide comprehensive global service for all of our components.

Please contact the Danfoss Power Solution representative nearest you.

Comatrol

www.comatrol.com

Turolla

www.turollaocg.com

Hydro-Gear

www.hydro-gear.com

Daikin-Sauer-Danfoss

www.daikin-sauer-danfoss.com

Local address:

**Danfoss
Power Solutions (US) Company**
2800 East 13th Street
Ames, IA 50010, USA
Phone: +1 515 239 6000

**Danfoss
Power Solutions GmbH & Co. OHG**
Krokamp 35
D-24539 Neumünster, Germany
Phone: +49 4321 871 0

**Danfoss
Power Solutions ApS**
Nordborgvej 81
DK-6430 Nordborg, Denmark
Phone: +45 7488 2222

**Danfoss
Power Solutions Trading
(Shanghai) Co., Ltd.**
Building #22, No. 1000 Jin Hai Rd
Jin Qiao, Pudong New District
Shanghai, China 201206
Phone: +86 21 3418 5200

Danfoss can accept no responsibility for possible errors in catalogues, brochures and other printed material. Danfoss reserves the right to alter its products without notice. This also applies to products already on order provided that such alterations can be made without changes being necessary in specifications already agreed. All trademarks in this material are property of the respective companies. Danfoss and the Danfoss logotype are trademarks of Danfoss A/S. All rights reserved.