



Series 40

M25 - Axial Piston

Pumps, Motors, and

Transmissions

Service and Repair Manual

Contents

Introduction	0 - 2
System Circuit Description	10 - 1
Functional Description	10 - 2
Technical Data - Pumps, Motors, and "U" Style Transmission	10 - 6
Safety Precautions	20 - 1
Gauge Installation	30 - 1
Start-Up Procedure and Maintenance	30 - 2
Component Inspections and Adjustments	30 - 3
Troubleshooting	30 - 5
Exploded View of the M25 Variable Pump	40 - 1
Exploded View of the M25 Variable Tandem Pump	40 - 5
Exploded View of the M25 Fixed Motor	40 - 9
Exploded View of the M25 Fixed Motor (Continued)	40 - 10
Exploded View of the M25 "U" Style Transmission	40 - 11
Minor Repair and Replacement	50 - 1
General	50 - 1
Minor Repair and Replacement - Pumps and Motors	50 - 2
Shaft Seal Replacement - PV / PT / MF	50 - 2
Trunnion Seal - PV / PT (Control Shaft Side)	50 - 3
Trunnion Cover - PV / PT (Plain)	50 - 3
Check and High Pressure Relief Valves - PV / PT	50 - 4
Charge Pressure Relief Valve - PV / PT	50 - 4
Easy-Ride Valves - PV	50 - 5
Auxiliary Pump Mounting Pad - PV / PT	50 - 5
Plug / Fitting Torques - PV / PT / MF	50 - 6
M25 Variable Pump, Tandem Pump, and Fixed Motor Conversion Information	50 - 6
Shaft Seal Replacement	50 - 7
Minor Repair and Replacement - "U" Style Transmission	50 - 7
Trunnion Seal Cover (Control Shaft Side)	50 - 8
Trunnion Cover (Plain)	50 - 8
Check and High Pressure Relief Valves	50 - 9
Charge Pressure Relief Valve	50 - 9
Filter Bypass Valve	50 - 10
Heat Exchanger Bypass Valve	50 - 10
Filter Bypass Reverse Flow Check Valve	50 - 11
Integral Charge Pump	50 - 11
Plug / Fitting Torques	50 - 13
M25 "U" Style Transmission Conversion Information	50 - 13
Major Repair - Variable Pump	61 - 1
General	61 - 1
Disassembly Procedures for Variable Displacement Pump	61 - 2
Reconditioning and Replacement of Parts	61 - 4
Assembly Procedures for Variable Displacement Pump	61 - 5
Major Repair - Tandem Pump	62 - 1
General	62 - 1
Disassembly Procedures for Tandem Pump	62 - 2
Reconditioning and Replacement of Parts	62 - 2
Assembly Procedures for Tandem Pump	62 - 3
Major Repair - Fixed Motor	63 - 1
General	63 - 1
Disassembly Procedures for Fixed Motor	63 - 2
Reconditioning and Replacement of Parts	63 - 3
Assembly Procedures for Fixed Motor	63 - 4
Major Repair - "U" Style Transmission	65 - 1
General	65 - 1
Disassembly Procedures for "U" Style Transmission	65 - 2
Reconditioning and Replacement of Parts	65 - 4
Assembly Procedures for "U" Style Transmission	65 - 5

Introduction

The purpose of this manual is to provide information necessary for the service and repair of the SAUER-SUNDSTRAND Series 40 - M25 Pumps, Motors, and "U" Style Transmissions.

This manual includes unit and component description, troubleshooting, adjustments, and minor and major repair procedures.

Minor Repairs are those repairs which can be performed without removing the housing(s) from the end cap or center section. These repairs can be performed by any customer without affecting the unit warranty.

Major Repairs are those repairs which require the removal of the housing(s) from the end cap or center section. These repairs are to be performed only by SAUER-SUNDSTRAND Authorized Service Centers and/or original equipment manufacturers who have been adequately trained by SAUER-SUNDSTRAND to perform these repairs. Performing major repairs on Series 40 products may affect the unit warranty status, thus the factory should be consulted prior to undertaking such repairs.

Many repairs or adjustments can be completed without removing the unit from the vehicle or machine, provided the unit is accessible and can be thoroughly cleaned before beginning any procedures.

Dirt or contamination is the greatest enemy of any type of hydraulic equipment. The greatest possible cleanliness is necessary when starting up the system, changing filters, or performing any other service procedure.

For Technical Information on Series 40 pumps and motors, refer to SAUER-SUNDSTRAND publications BLN-9989 and BLN-9990.

For Fluid Quality Requirements, refer to publication BLN-9987 or 697581.

SAUER-SUNDSTRAND provides a complete repair service for its products. Contact any SAUER-SUNDSTRAND Authorized Service Center for details. SAUER-SUNDSTRAND Authorized Service Center locations are listed in publication BLN-2-40527 or 698266.



40250001

Fig. 0-1 - Series 40-M25 Variable Displacement Pump and Tandem Pump



40250118

Fig. 0-2 - Series 40-M25 Fixed Displacement Motor



40250002

Fig. 0-3 - Series 40-M25 "U" Style Transmission

System Circuit Description

The Series 40 - M25 pumps, motors, and “U” style transmission can be applied in drive systems to transfer and control power. These units provide an infinitely variable speed range between zero and maximum, in both forward and reverse modes of operation.

Series 40 - M25 pumps, motors, and transmissions incorporate a compact, state-of-the-art design, using the parallel axial piston / slipper design in conjunction with a tiltable swashplate to vary the pump’s displacement. Reversing the direction of tilt of the variable pump swashplate reverses the flow of oil from the pump and thus reverses the direction of the motor output rotation.

A direct displacement control system is used on the Series 40 - M25 pumps and M25 “U” transmission pump. The swashplate control shaft is connected directly to the swashplate. Movement of the control shaft causes a proportional swashplate movement and change in pump flow. This control can be located on either side of the unit.

A charge relief valve and charge check valves are included in the variable pump end cap and tandem pump center section to control the makeup and cooling oil flow for the system. The charge check valves also incorporate the bypass valve function and high pressure relief valve function into their design.

The Series 40 - M25 variable and tandem pumps do not have an integral charge pump. They are equipped with an SAE “A” auxiliary pad, which may be used to drive a fixed displacement gear pump to provide charge flow and other services.

The Series 40 - M25 fixed displacement motor also incorporates the parallel axial piston / slipper design, utilizing a fixed swashplate angle.

The Series 40 - M25 “U” transmission incorporates a variable pump and a fixed motor in a common housing. This unit includes a 5.98 cc/rev (0.365 in³/rev) integral gerotor type charge pump. The transmission center section includes the charge pressure relief valve, an oil cooler bypass valve, a filter bypass valve and reverse flow check valve, and the charge check/high pressure relief valves.

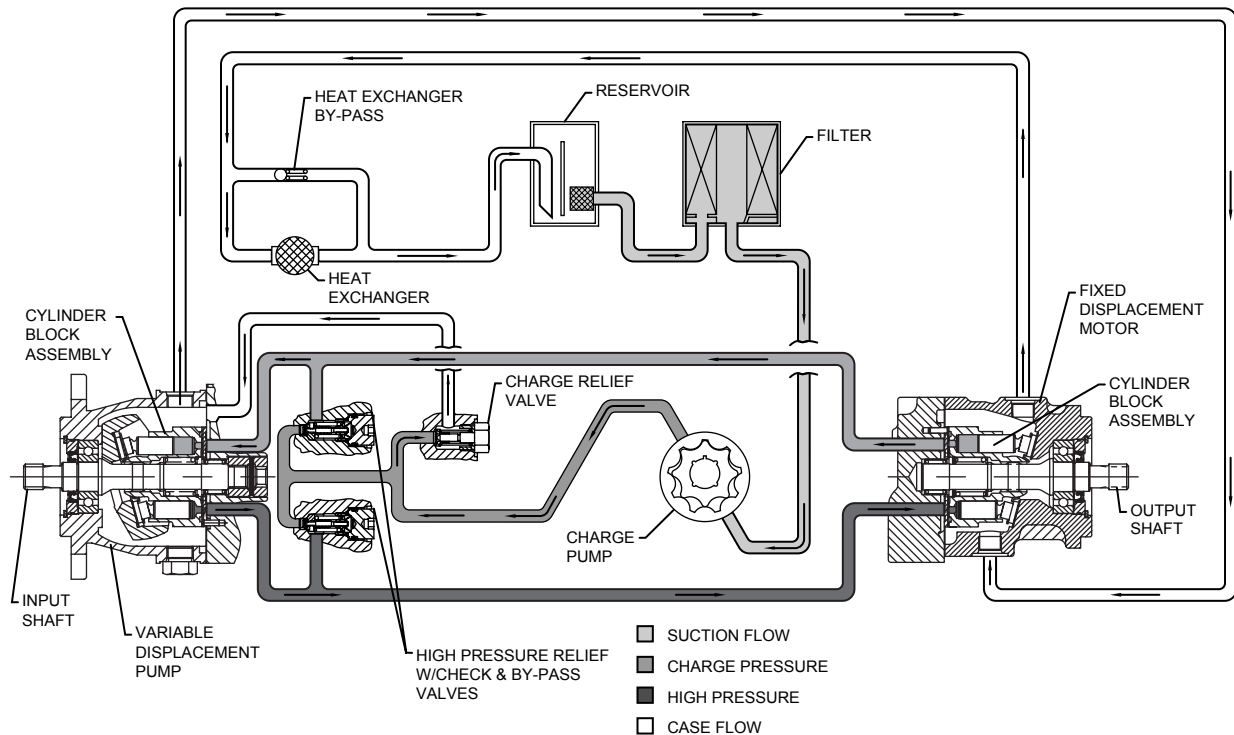

Fig. 10-1 - Typical Series 40 - M25 Variable Pump – Fixed Motor Transmission Schematic

40250112

Functional Description

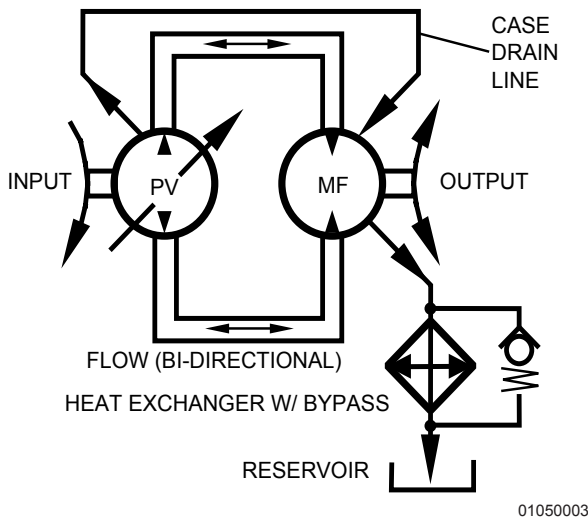

Fig. 10-2 - Basic Closed Circuit

Basic Closed Circuit

The main ports of the pump are connected by hydraulic lines (or passages in the M25U transmission center section) to the main ports of the motor. Fluid flows, in either direction, from the pump to the motor then back to the pump in this closed circuit. Either of the hydraulic lines can be under high pressure. The direction and speed of fluid flow (and the motor output shaft rotation) depends on the position of the pump swashplate. The system pressure is determined by the machine load.

Case Drain and Heat Exchanger

The variable pump, tandem pump, and transmission require case drain connections to remove hot fluid from the system.

The variable pump case should be drained from the upper drain port insure the case remains full of fluid. The tandem pump case should be drained from the upper drain port of the rear pump section. The pump case drain is connected to the lower drain port on the motor housing. The upper motor housing drain port is then connected to the reservoir. A heat exchanger, with a bypass valve, may be required to cool the case drain fluid before it returns to the reservoir.

The M25U transmission case is usually drained through the output and PTO shaft bearings. Ports for connecting a heat exchanger into the charge circuit are located in the transmission center section. A heat exchanger bypass valve is incorporated into the transmission center section.

CAUTION

Continuous case pressure should not exceed 1.7 bar (25 psi).

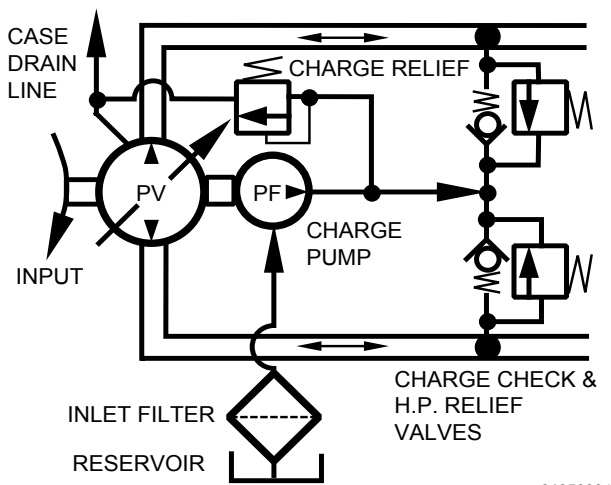

Fig. 10-3 - Charge System (Typical for Variable Pump and Tandem Pump)

Charge System and Filter

The charge pump is used to supply cool fluid to the system and keeps the closed loop charged to prevent cavitation. The charge pump draws its fluid from the system reservoir.

CAUTION

Sufficient charge flow MUST be provided to the charge inlet port of the M25 variable pump or tandem pump to ensure that charge pressure is maintained whenever the pump is operating.

A filter is required to insure that only clean fluid enters the closed loop.

Either suction or pressure filtration may be used with the M25 variable and tandem pump.

Functional Description (Continued)

The M25U transmission includes an integral pressure filter mount on the transmission center section. A filter bypass valve and a filter bypass reverse flow check valve are incorporated into the transmission center section.

CAUTION

For the M25 “U” style transmission, the charge pump inlet vacuum should not exceed .8 bar abs. (5 in. Hg), except during cold starts. For the M25 pumps, refer to the specifications for the specific charge pump being used.

Since either of the main hydraulic lines can be at high pressure, charge check valves are used to direct the charge supply into the low pressure side of the closed loop. These check valves (located in the tandem pump center section or transmission center section) may also incorporate the high pressure relief valve function. Any charge flow not being used for the closed circuit is discharged over a direct operating charge relief valve, through the tandem pump or transmission housing, and back to the system reservoir.

High Pressure Relief Valves

Optional combination check / high pressure relief valves may be provided in the variable pump end cap or tandem pump center section for overload protection. Combination check / high pressure relief valves are provided in the “U” style transmission center section. These cartridge type relief valves are factory set, and are not field adjustable. Changing the maximum system pressure can be accomplished by installing different cartridges with the desired setting.

Direct Displacement Control

The direct displacement control (DDC) may be located on either side of the unit, and provides a simple method of control. Movement of the swashplate control shaft produces a proportional swashplate movement and change in pump flow and motor shaft speed and/or direction.

The vehicle / machine control system must be designed to return the swashplate to its neutral position.

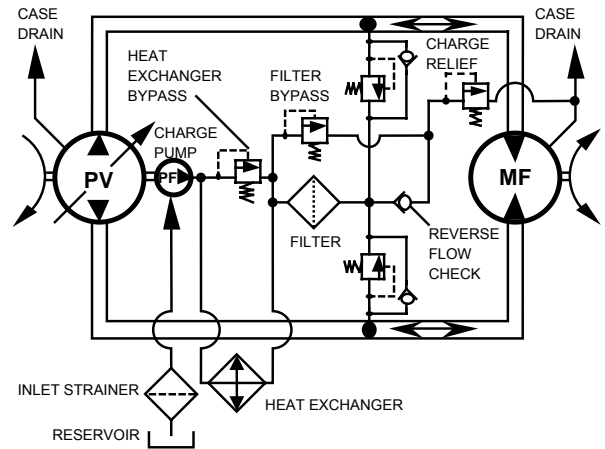

40250003

Fig. 10-4 - Charge System (“U” Style Transmission)



40250004

Fig. 10-5 - Tandem Pump with Direct Displacement Control

Functional Description (Continued)

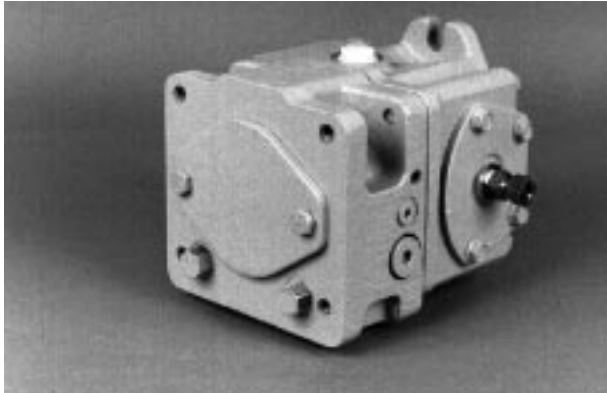

Fig. 10-6 - Variable Pump with Auxiliary Mounting Pad

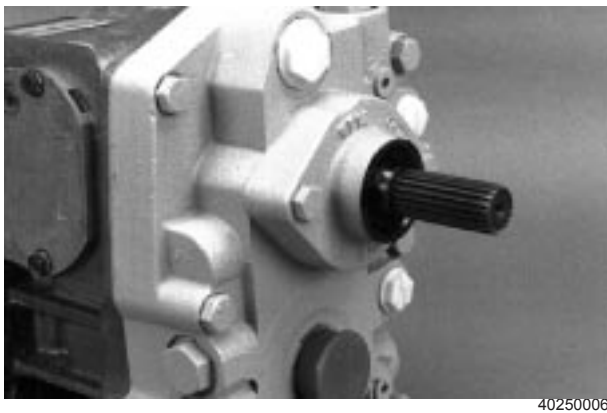

Fig. 10-7 - "U" Style Transmission with Charge Pump

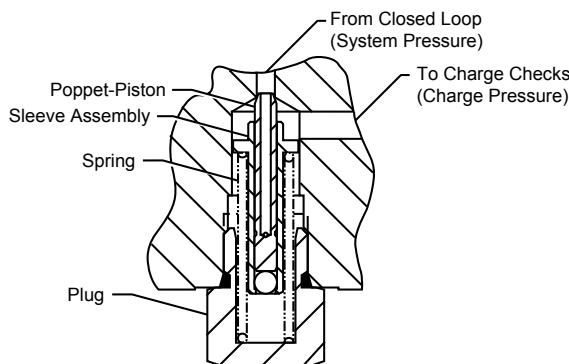

Fig. 10-8 - Cross-Section View of Easy-Ride Valve

Auxiliary Mounting Pads

An SAE "A" auxiliary mounting pad is standard on Series 40 - M25 variable and tandem pumps. This pad is used for mounting an auxiliary hydraulic pump or separate charge pump. Either a 9 tooth or 11 tooth drive spline is available

The M25U transmission includes a 22 tooth, 24/48 pitch splined PTO drive on the rear end of the pump drive shaft.

Charge Pumps

The M25 variable pump and tandem pump do not include integral charge pumps, and require that a separate, fixed displacement charge pump be provided as part of the system.

A fixed displacement, gerotor type charge pump is provided as a part of the M25U transmission.

Easy-Ride Valves (Variable Pump)

The M25 variable pump is available with optional Easy-Ride valves to reduce the rate of change in acceleration ("jerkiness") in vehicle propel applications. These valves limit the rate of pressure rise in the closed loop by permitting flow from the high to the low pressure side (through the charge circuit) when system pressure increases suddenly.

Each Easy-Ride valve consists of a poppet-piston, sleeve assembly, spring, and plug, which are installed in the pump end cap. The poppet-piston and its seat form a valve to close off the passage between one side of the closed loop and the charge pressure passage. The spring pre-loads the sleeve assembly and holds the poppet-piston closed against its seat in the end cap when loop pressure is low.

A sudden increase in loop pressure will force the poppet-piston off its seat, allowing some high pressure fluid to flow to the opposite side of the loop through the charge check. This limits the pressure rise rate in the loop and reduces the acceleration rate of the vehicle.

Loop pressure is orificed into the space between the poppet-piston and the sleeve assembly through ports in the poppet-piston and the clearance between it and the sleeve. The sleeve moves, compressing the spring until the spring force equals the hydraulic force.

Functional Description (Continued)

Once the sleeve assembly stops moving, the pressure between the poppet-piston and sleeve moves the poppet-piston toward its seat, sealing off the passage. If the loop pressure is above the functional range of the valve (approximately 103 bar [1500 psi]), the sleeve assembly will contact the plug and the poppet-piston will be rapidly forced onto its seat.

A typical Easy-Ride valve cycle requires 0.5 to 1.0 seconds, depending on system oil viscosity and loop pressure.

Bypass Valve (Variable Pump and Tandem Pump)

In some applications it is desirable to bypass fluid around the variable displacement pump allowing, for example, a vehicle to be moved short distances at low speeds without running the prime mover. This is accomplished by manually operated bypass valves incorporated into the charge check / high pressure relief valves in the variable pump or tandem pump.

When open (unscrewed 4 turns maximum), these valves connect both sides of the pump/motor closed circuit, allowing the motor to turn. Both valves must be opened for bypass operation., and must be fully closed for normal operation. The system prime mover should be shut down when opening or closing the bypass valves.

NOTE: Opening the bypass valves more than 4 turns may result in external leakage.

WARNING

Opening the bypass valves will result in a loss of hydrostatic braking capacity. Take precautions to prevent unexpected machine movement when opening the valves.

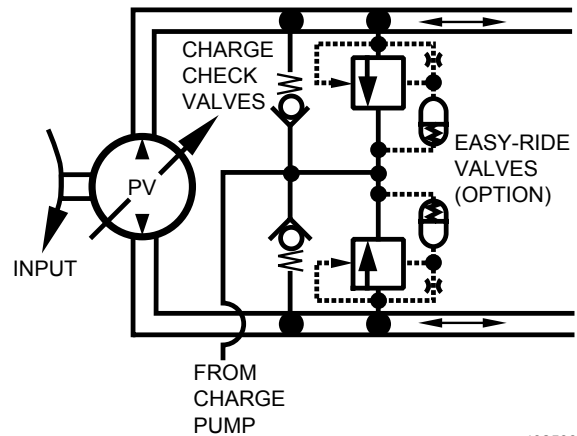

Fig. 10-9 - Variable Pump Circuit with Easy-Ride Valves

40250008

Technical Data - Pumps, Motors, and “U” Style Transmission

Product Type		M25 Variable Pump	M25 Tandem Pump	M25 Fixed Motor	M25 “U” Style Transmission
Displacement cc/rev in ³ /rev		25 1.5	25 (each section) 1.5 (each section)	25 1.5	25 (Pump & Motor) 1.5 (Pump & Motor)
Maximum Allowable Speed Full Angle (variable units) - rpm		5000	ALL UNITS →		
Mounting Flange (per SAE J744)		SAE B	SAE B	SAE B	DNA
Input Shaft (Std. Spline) Number of Teeth and Pitch		13T, 16/32	15T, 16/32	DNA	Input: 20T, 24/48 PTO: 22T, 24/48
Output Shaft (Std. Spline) Number of Teeth and Pitch		DNA	DNA	13T, 16/32	18T, 16/32
Weight	kg lbs	19 41.5	24.9 55	11 25	25.4 56
Pressure Maximum Continuous	bar psi bar psi	345 5000 210 3000	} ALL UNITS →		
Case Pressure Continuous Maximum (Cold Start)	bar psi bar psi	1.7 25 5.2 75	} ALL UNITS →		
Temperature at Hottest Point in Transmission (normally at case drain) Maximum Continuous	°C °F °C °F	104 220 82 180	} ALL UNITS →		
Fluid Viscosity Limits mm²/sec (SUS) Optimum Min. Continuous Min. Intermittent Max. Continuous Max. Cold Start		13 (70) 9.0 (55) 6.4 (47) 110 (500) 1600 (7500)	} ALL UNITS →		
Suggested Filtration Dedicated Reservoir Common Reservoir		Beta 10 = 1.5 to 2.0 Beta 10 = 10 to 20	} ALL UNITS →		
Charge Inlet Vacuum at Sea Level Normal Cold Start	bar (abs.) in. Hg bar (abs.) in. Hg	Refer to specifications for specific Charge Pump being used.	Refer to specifications for specific Charge Pump being used.	DNA	.8 5 .7 10

DNA = Does Not Apply

Safety Precautions

- When Series 40 units are used in vehicular hydrostatic drive systems, the loss of hydrostatic drive line power in any mode (acceleration, deceleration, or “neutral” mode) of operation may cause a loss of hydrostatic braking capacity. A braking system, redundant to the hydrostatic transmission must, therefore, be provided which is adequate to stop and hold the system should the condition develop.
- Certain service procedures may require the vehicle/machine to be disabled (wheels raised off the ground, work function disconnected, etc.) while performing them in order to prevent injury to the technician and bystanders.

- Use caution when dealing with hydraulic fluid under pressure. Escaping hydraulic fluid under pressure can have sufficient force to penetrate your skin causing serious injury. This fluid may also be hot enough to burn. Serious infection or reactions can develop if proper medical treatment is not administered immediately.
- Some cleaning solvents are flammable. To avoid possible fire, do not use cleaning solvents in an area where a source of ignition may be present.

Notes

Gauge Installation

Gauge Ports

Various pressure and vacuum gauge readings can be a great asset in troubleshooting problems with the Series 40 - M25 transmission or support system.

It will be necessary to connect a high pressure gauge to the system pressure gauge ports (variable pump, fixed motor, and "U" style transmission) or tee into the system high pressure lines (tandem pump) to check the setting of the system pressure relief valves.

Measuring the charge pump inlet vacuum will help locate restrictions in the inlet lines, filter, etc.

Case pressure readings can help locate restrictions in the return lines, return oil cooler, and return filter.

Gauge Information		
M1 or "A"	System Pressure Port "A"	600 bar or 10,000 psi Gauge 7/16 — 20 O-Ring Fitting (PV/U) 9/16 — 18 O-Ring Fitting (MF) Tee into high press. line (PT)
M2 or "B"	System Pressure Port "B"	600 bar or 10,000 psi Gauge 7/16 — 20 O-Ring Fitting (PV/U) 9/16 — 18 O-Ring Fitting (MF) Tee into high press. line (PT)
M3 or "E"	Charge Pressure	60 bar or 1000 psi Gauge Tee into Charge Supply (PV/PT) 7/16 — 20 O-Ring Fitting (U)
"L1"	Case Pressure	60 bar or 1000 psi Gauge 7/8 — 14 O-Ring Fitting (PV/PT) 3/4 — 16 O-Ring Fitting (MF)
"L2"	Case Pressure	60 bar or 1000 psi Gauge 7/8 — 14 O-Ring Fitting (PV/PT) 3/4 — 16 O-Ring Fitting (MF)
"S"	Charge Pump Inlet Vacuum	Vacuum Gauge Tee into Charge Pump Inlet Line

NOTE: Tandem pumps have two (2) additional system ports in the rear section.

Snubbers are recommended to protect pressure gauges. Frequent gauge calibration is necessary to insure accuracy.

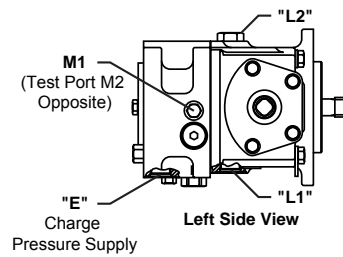

Fig. 30-1 - Gauge Connections — Variable Pump

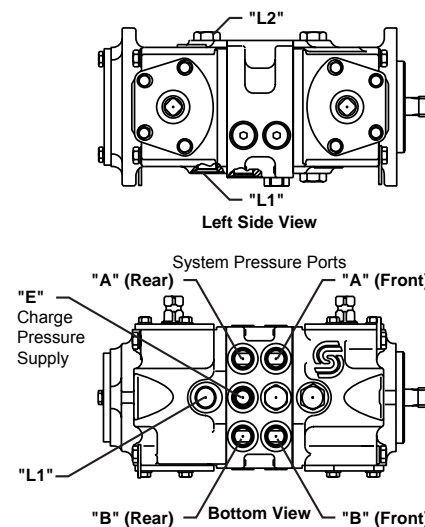

Fig. 30-2 - Gauge Connections — Tandem Pump

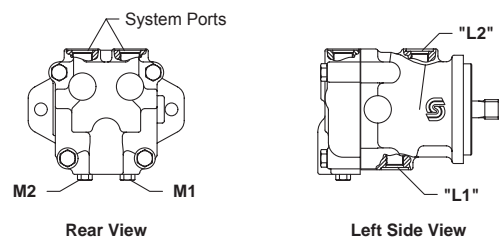

Fig. 30-3 - Gauge Connections — Fixed Motor

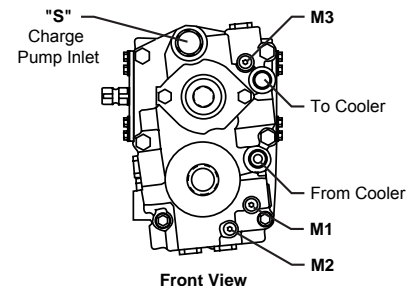

Fig. 30-4 - Gauge Connections — "U" Style Transmission

Start-Up Procedure and Maintenance

Fluids

Hydraulic fluids used with Sauer-Sundstrand products should be carefully selected with assistance from a reputable supplier, following the guidelines presented in SAUER-SUNDSTRAND Bulletin BLN-9887 or Publication SDF (Id. No. 697581).

Start-Up Procedure

The following start-up procedure should always be followed when starting-up a new installation or when restarting an installation in which either the pump or motor had been removed from the system.

WARNING

The following procedure may require the vehicle/machine to be disabled (wheels raised off the ground, work function disconnected, etc.) while performing the procedure in order to prevent injury to the technician and bystanders.

Prior to installing the pump or transmission, inspect the unit for damage incurred during shipping and handling. Make certain all system components (reservoir, hoses, valves, fittings, heat exchanger, etc.) are clean prior to filling with fluid.

Fill the reservoir with recommended hydraulic fluid which should be passed through a 10 micron (nominal, no bypass) filter prior to entering the reservoir.

The inlet line leading from the reservoir to the charge pump must be filled prior to start up. Check inlet line for properly tightened fittings and make sure it is free of restrictions and air leaks.

Be certain to fill the pump, motor, and/or transmission housing with clean hydraulic fluid prior to start up. Fill the housing by pouring filtered oil into the upper case drain port.

Install a 0 to 60 bar or 0 to 1000 psi pressure gauge in the charge pressure gauge port to monitor the charge pressure during start-up.

With the pump swashplate in its neutral (0 angle) position, "jog" or slowly rotate prime mover until charge pressure starts to rise. Start the prime mover and run at the lowest possible RPM until charge pressure has been established. Excess air may be bled from the high pressure lines through the high pressure gauge ports or by carefully loosening the high pressure lines.

WARNING

Do not start prime mover unless pump is in neutral position (0 swashplate angle). Take precautions to prevent machine movement in case pump is actuated during initial start up.

Once charge pressure has been established, increase speed to normal operating RPM. Charge pressure should be a minimum of 7 bar (100 psi) above case pressure. If charge pressure is incorrect, shut down and determine cause for improper pressure.

With motor output shaft disconnected or drive wheels raised off of the ground, run system at full input and output speeds in both directions. Operate system for at least fifteen (15) minutes.

Shut down prime mover, remove gauges, and plug ports. Check reservoir level and add fluid if necessary.

The transmission is now ready for operation.

Maintenance

To insure optimum service life on Series 40 - M25 products, regular maintenance of the fluid and filter must be performed.

Check the reservoir daily for proper fluid level, the presence of water (noted by a cloudy to milky appearance, or free water in bottom of reservoir), and rancid fluid odor (indicating excessive heat).

The fluid and filter must be changed per the vehicle/machine manufacturer's recommendations. In the absence of such recommendations, the following intervals may be used:

- System with a sealed type reservoir - 2000 hrs.
- System with a breathing type reservoir - 500 hrs.

It may be necessary to change the fluid more frequently than the above intervals if the fluid becomes contaminated with foreign matter (dirt, water, grease, etc.) or if the fluid has been subjected to temperature levels greater than the maximum recommended. Never reuse fluid.

The filter should be changed whenever the fluid is changed or whenever the filter indicator shows that it is necessary to change the filter.

Component Inspections and Adjustments

Direct Displacement Control

Inspect the connection of the control linkage to the swashplate control shaft to insure that the linkage is properly attached. Neutral position of the swashplate is determined by the vehicle/machine control linkage.

Check / High Pressure Relief Valves

When a problem occurs in one direction, interchange the charge check or check/relief valves to see if the problem changes to the other direction. If so, one valve is malfunctioning or the check/relief valve cartridge does not have the proper setting.

CAUTION

The relief valves are factory set and should not be tampered with except for replacing the entire cartridge. Disassembly may change the setting and cause erratic unit operation or premature failure.

The pressure setting of the valve (in bar) is indicated by a three (3) digit code stamped on the cartridge. For the M25 PV and PT, the cartridge must be removed from the special plug in order to read the code.

When reinstalling, torque the plugs to 41 to 68 Nm (30 to 50 lbf•ft) for the M25 PV and PT, or 41 to 95 Nm (30 to 70 lbf•ft) for the M25 “U” style transmission.

Bypass Valves (Variable Pump / Tandem Pump)

The bypass function is accomplished by manually opening the charge check / high pressure relief valves. If the system is operating hot, check that the valves are fully seated by turning the special plugs (four [4] on tandem pumps) clockwise with a 5/16" internal hex wrench. Torque the plugs to 41 to 68 Nm (30 to 50 lbf•ft).

Pump Charge Relief Valve

If charge pressure is low, the charge relief valve should be inspected. Inspect for foreign material holding the poppet open, and for scoring or wear on the poppet and seat in the end cap or center section.

Adjustment of the charge pressure is accomplished by changing the shim thickness behind the spring. The variable pump and tandem pump charge pressure relief valve is usually factory set at 13.8 bar Δ (200 psi) above case pressure under test conditions. The “U” style transmission charge pressure relief valve is usually factory set at 11.7 bar Δ (170 psi) above case pressure under test conditions. Exact charge pressure may vary in various applications.



Fig. 30-5 - Check / High Pressure Relief Valves (PV / PT)



Fig. 30-6 - Check / High Pressure Relief Valves (U)

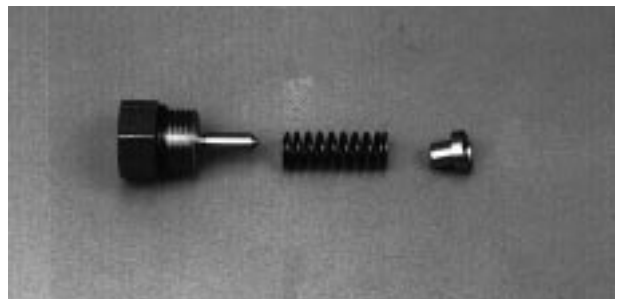

Fig. 30-7 - Charge Relief Valve (PV / PT)



Fig. 30-8 - Charge Relief Valve (U)

Component Inspections and Adjustments (Continued)

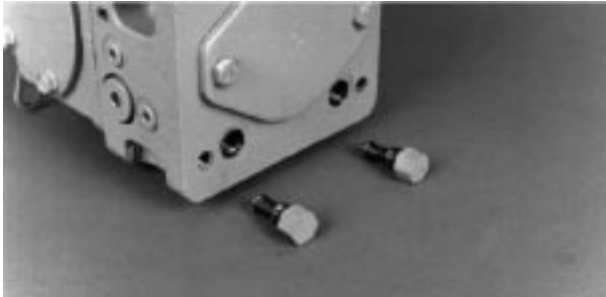

Fig. 30-9 - Easy-Ride Valves (PV)

40250013

Easy-Ride Valves (Variable Pump)

When a problem occurs in one direction, interchange the Easy-Ride valves to see if the problem changes to the other direction. If so, one valve is malfunctioning.

Inspect for foreign material holding the poppet/piston off its seat, and for roughness or wear on the poppet surface and its seat in the end cap. The poppet/piston must slide freely in the sleeve assembly.



Fig. 30-10 - Heat Exchanger Bypass Valve (U)

40250014

Heat Exchanger Bypass Valve (“U” Style Transmission)

If the M25U transmission is operating hot, the heat exchanger bypass valve (in the transmission center section) should be inspected. Inspect for foreign material holding the poppet open, and for scoring or wear on the poppet and seat in the housing.

Earlier production transmissions use a heat exchanger bypass valve with a nominal setting of 7.4 bar Δ (107 psi). The spring for this valve has a yellow dye mark and requires a force of approximately 22 N (5.5 lbf) to compress it to a length of 45.7 mm (1.28 inches).

Later production transmissions use a heat exchanger bypass valve with a nominal setting of 4.8 bar Δ (70 psi). The spring used in this valve has a red dye mark and requires a force of approximately 10 N (2.2 lbf) to compress it to a length of 45.7 mm (1.28 inches).



Fig. 30-11 - Filter Bypass Valve (U)

40250015

Filter Bypass and Reverse Flow Check Valves (“U” Style Transmission)

Inspect the filter bypass and reverse flow check valves for foreign material holding the poppet open, and for scoring or wear on the poppet and seat in the housing.

The filter bypass valve has a nominal setting of 4.8 bar Δ (70 psi). The spring used in this valve has a red dye mark and requires a force of approximately 10 N (2.2 lbf) to compress it to a length of 45.7 mm (1.28 inches).

The spring used in the reverse flow check valve has a blue dye mark and requires a force of approximately 1.3 N (0.3 lbf) to compress it to a length of 45.7 mm (1.28 inches).

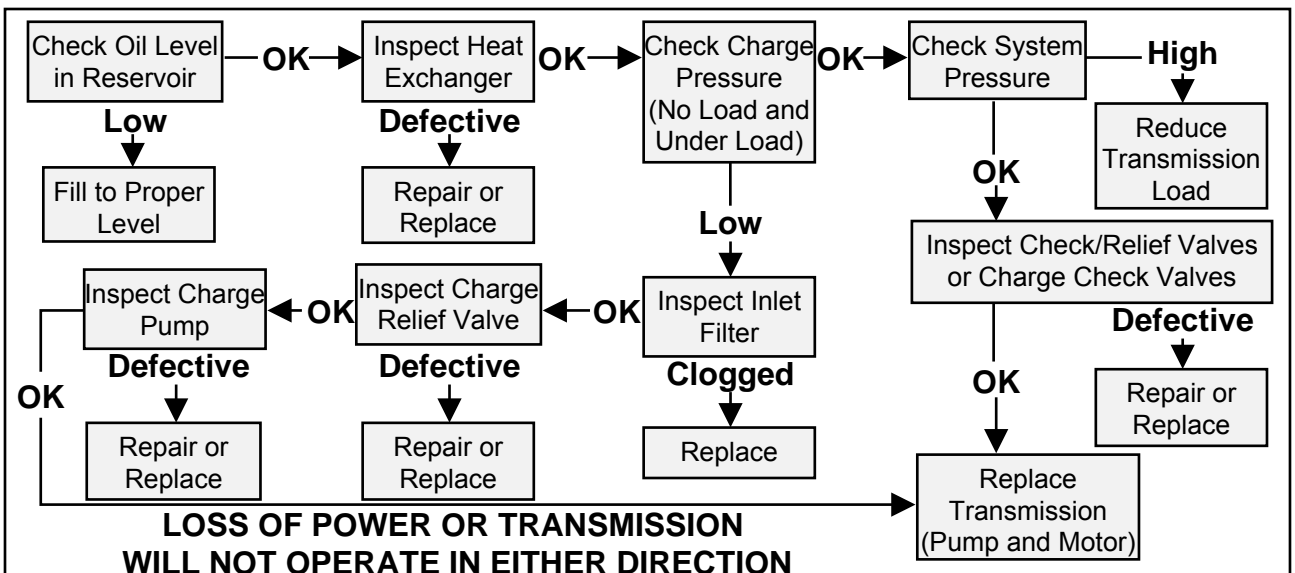
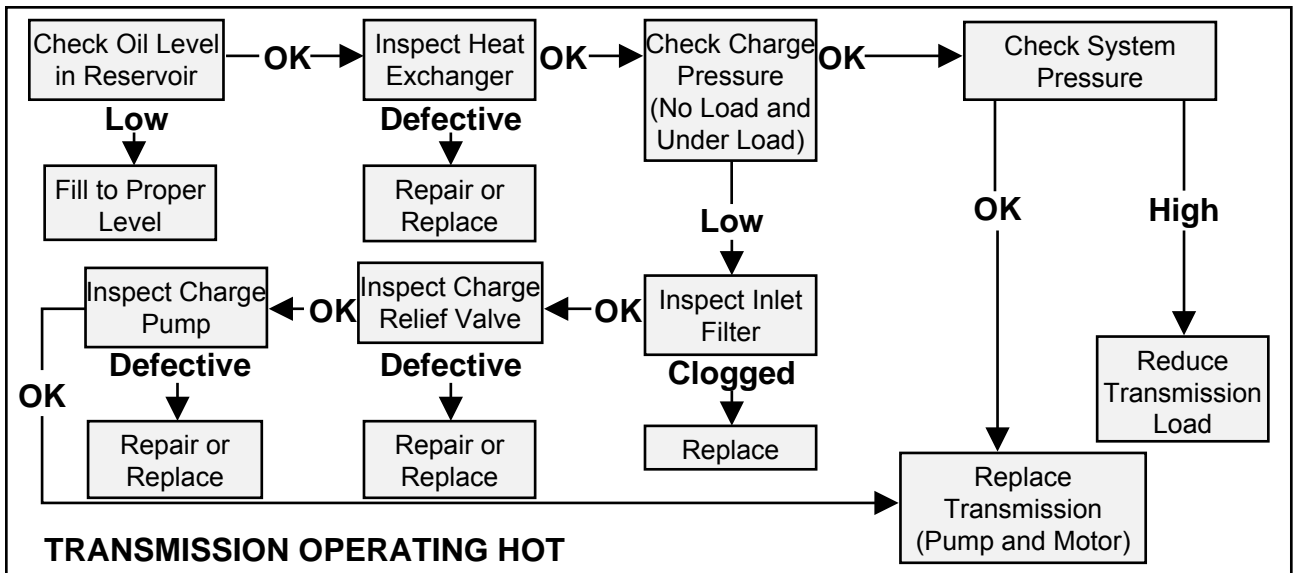
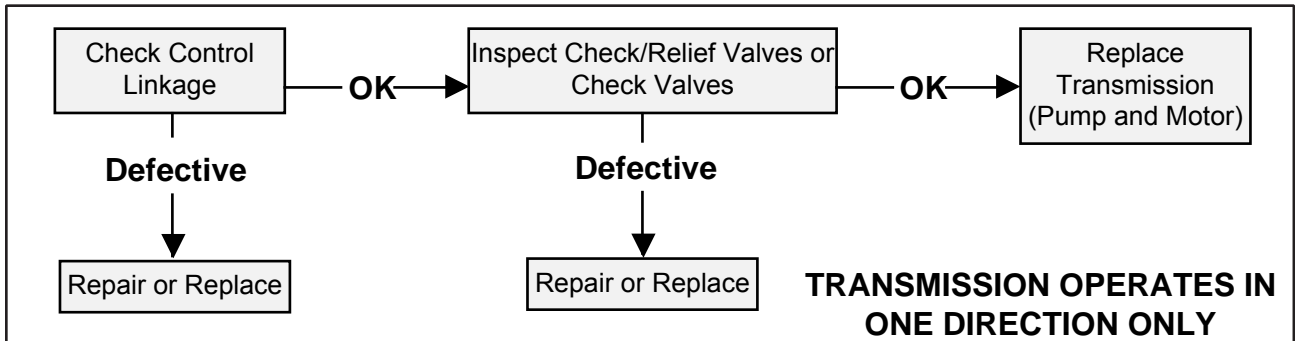

Fig. 30-12 - Filter Bypass Reverse Flow Check Valve (U)

40250016

Troubleshooting

Fault-Logic Diagrams



Notes

Exploded View of the M25 Variable Pump

The following information is for general parts identification ONLY. Refer to the applicable Service Parts List when ordering service parts.

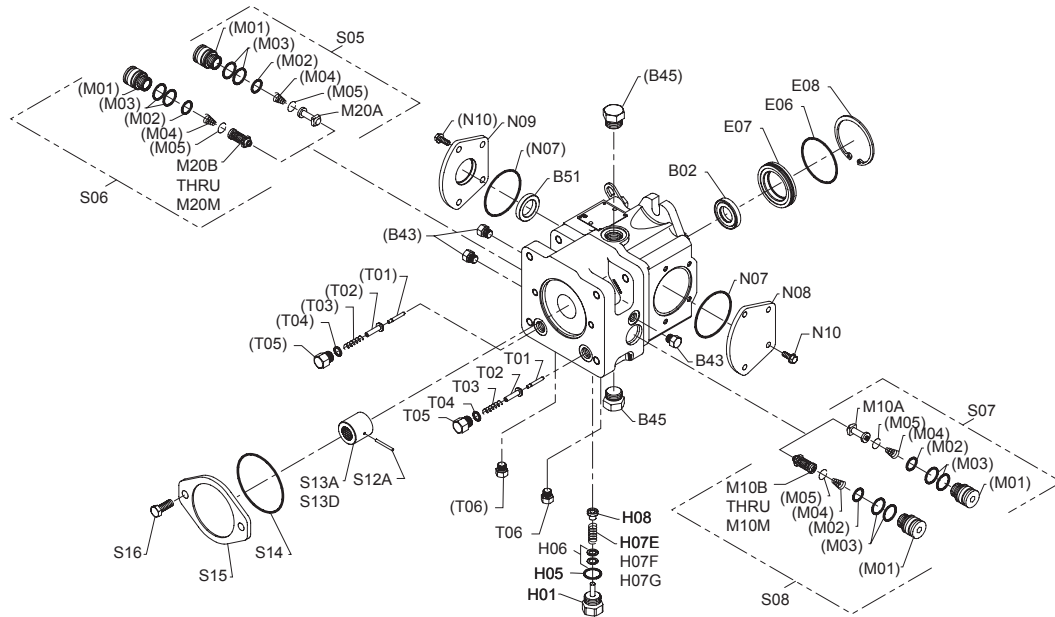

Name Plate

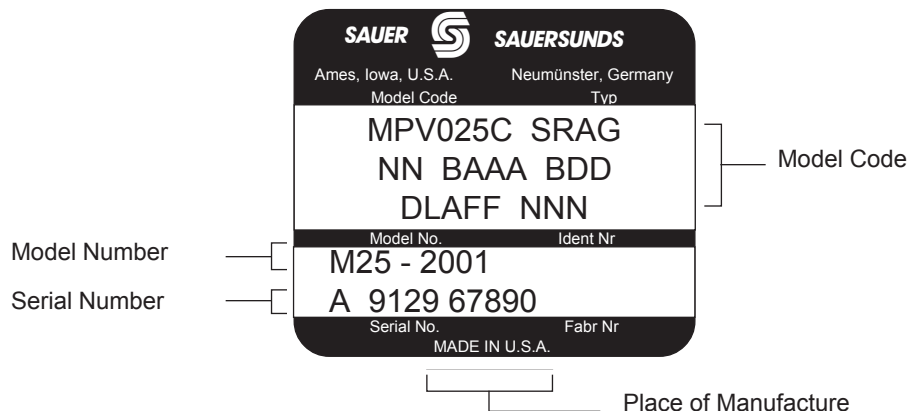

Exploded View of the M25 Variable Pump (Continued)

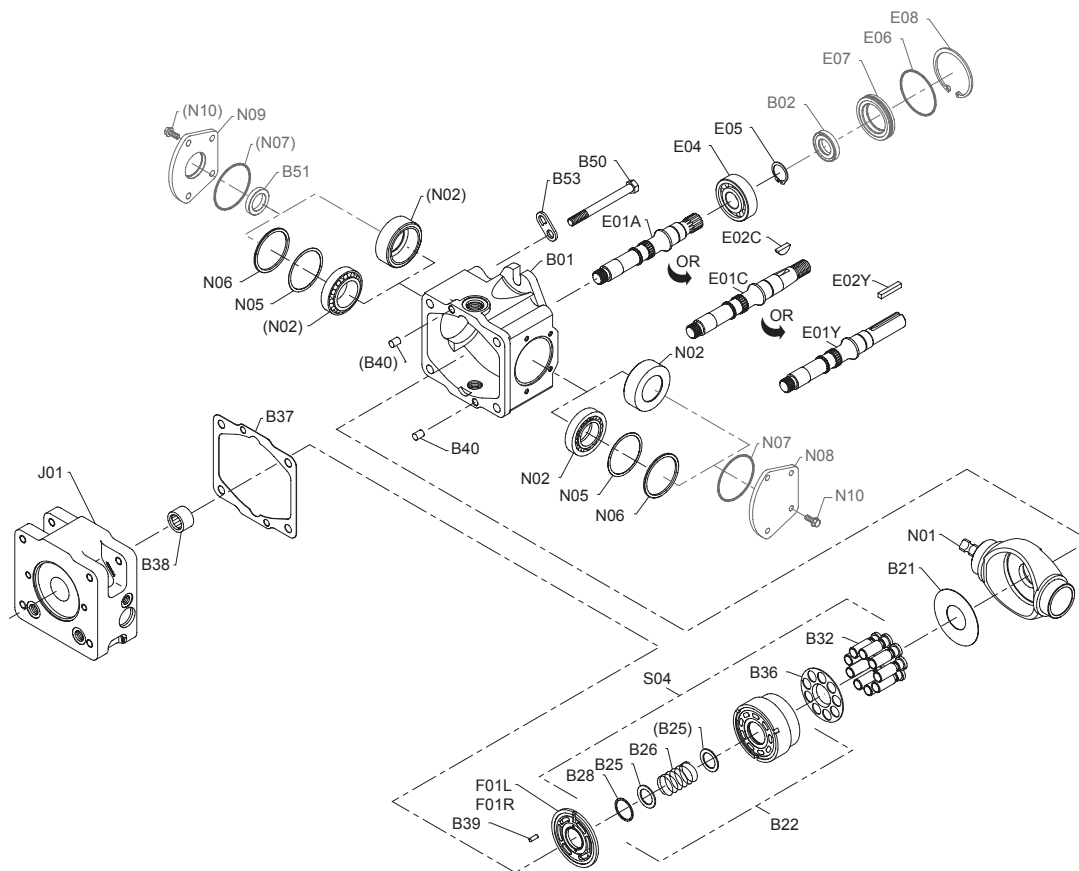

Exploded View of the M25 Variable Pump (Continued)

Item	Description	Qty	Item	Description	Qty
B01	HOUSING, VARIABLE	1	H07F	SPRING, HEL COMP (7 BAR/100PSI)	1
B02	SEAL, LIP	1	H07G	SPRING, HEL COMP (14 BAR/200PSI)	1
B21	PLATE, THRUST	1			
B22	CYLINDER BLOCK KIT	1	M10A	POPPET-CHECK VALVE	1
B32	PISTON ASSY	9	M20A	POPPET-CHECK VALVE	1
B36	RETAINER, SLIPPER	1	M10B	VALVE, RELIEF	1
B26	SPRING	1	THRU		
B25	WASHER	2	M10M		
B28	RING, RETAINING	1	M20B	VALVE, RELIEF	1
B37	GASKET, END CAP	1	THRU		
B38	BEARING, NEEDLE	1	M20M		
B39	PIN, ST HDLS	1			
B40	PIN	2	E01C	SHAFT, PUMP - TAPERED	1
B42	PLUG, PLASTIC	1	E02C	KEY	1
B44	PLUG, PLASTIC	3	E01K	SHAFT, PUMP - STR KEYED	1
B45	PLUG, ST THD	1	E02K	KEY, SQUARE	1
B49	SCREW, DRIVE	2	E01S	SHAFT, PUMP - SPLINED 13T	1
B50	SCREW, HEX HD	4			
B51	SEAL, LIP	1	F01L	PLATE, VALVE (LH)	1
B52	WASHER	3	F01R	PLATE, VALVE (RH)	1
B53	LIFTING BRACKET	1			
E04	BEARING, BALL	1	S12A	PIN	1
E05	RING, RETG	1	S13A	COUPLING - 9T AUX DRIVE	1
E06	O-RING	1	S13D	COUPLING - 11T AUX DRIVE	1
E07	CARRIER, SEAL	1			
E08	RING, INTERNAL RETAINING	1	T01	PISTON	2
H01	PLUG ASSY, CHG RELIEF	1	T02	SLEEVE ASSY	2
H05	O-RING	1	T03	SPRING, HEL COMP	2
H06	SHIM, CHG. RELIEF	AR	T04	O-RING	2
H08	POPPET, CHG.RELIEF	1	T05	PLUG, SPECIAL	2
J01	END CAP	1			
M01	PLUG, SPECIAL	2	N01	SWASHPLATE, VARIABLE	1
M02	O-RING	2	N02	BEARING CARRIER ASSY	2
M03	O-RING	2			
M04	SPRING, CONICAL COMP	2	N01	SWASHPLATE-VARIABLE	1
M05	RING, INTERNAL RETAINING	2	N02	BEARING-TAPER ROLLER	2
N07	O-RING	2	N05	SHIM-TRUNNION	AR
N08	COVER, TRUNNION (PLAIN)	1	N06	SPACER-TRUNNION	2
N09	COVER, TRUNNION	1			
N10	SCREW	8			
S14	O-RING	1			
S15	PLATE, PAD COVER	1			
S16	SCREW, HEX HD	2			

Notes

Exploded View of the M25 Variable Tandem Pump

The following information is for general parts identification ONLY. Refer to the applicable Service Parts List when ordering service parts.

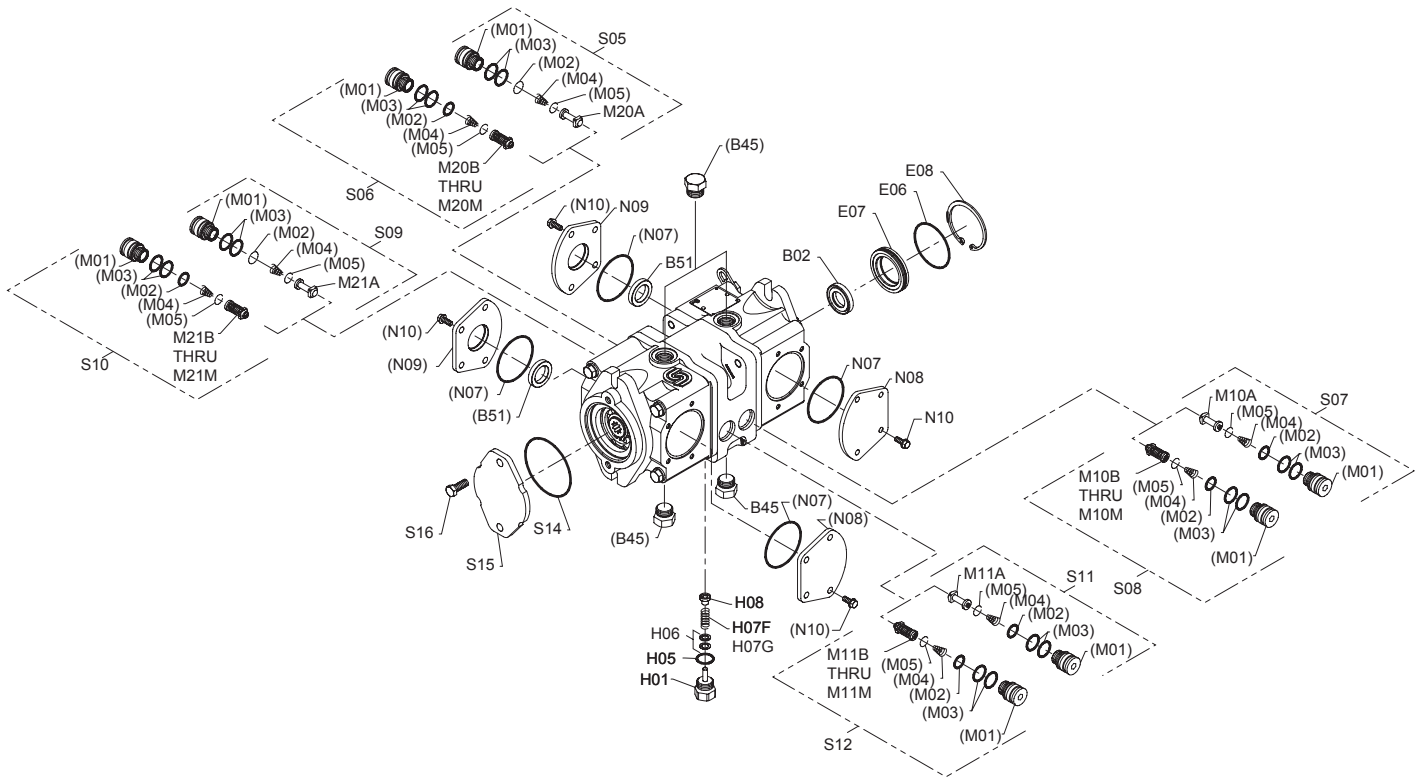

Name Plate

SAUER SAUERSUNDS	
Ames, Iowa, U.S.A.	Neumünster, Germany
Model Code	Typ
MPT025C SRAG NN BAAA BDD DLAFF + BCAA BDD DRAFF A NN	
Model No.	Ident Nr
M91 - 25103	
Serial No.	Fabr Nr
A 8926 67890	
MADE IN U.S.A.	

Model Number —

Serial Number —

Model Code —

Place of Manufacture —

Exploded View of the M25 Variable Tandem Pump (Continued)

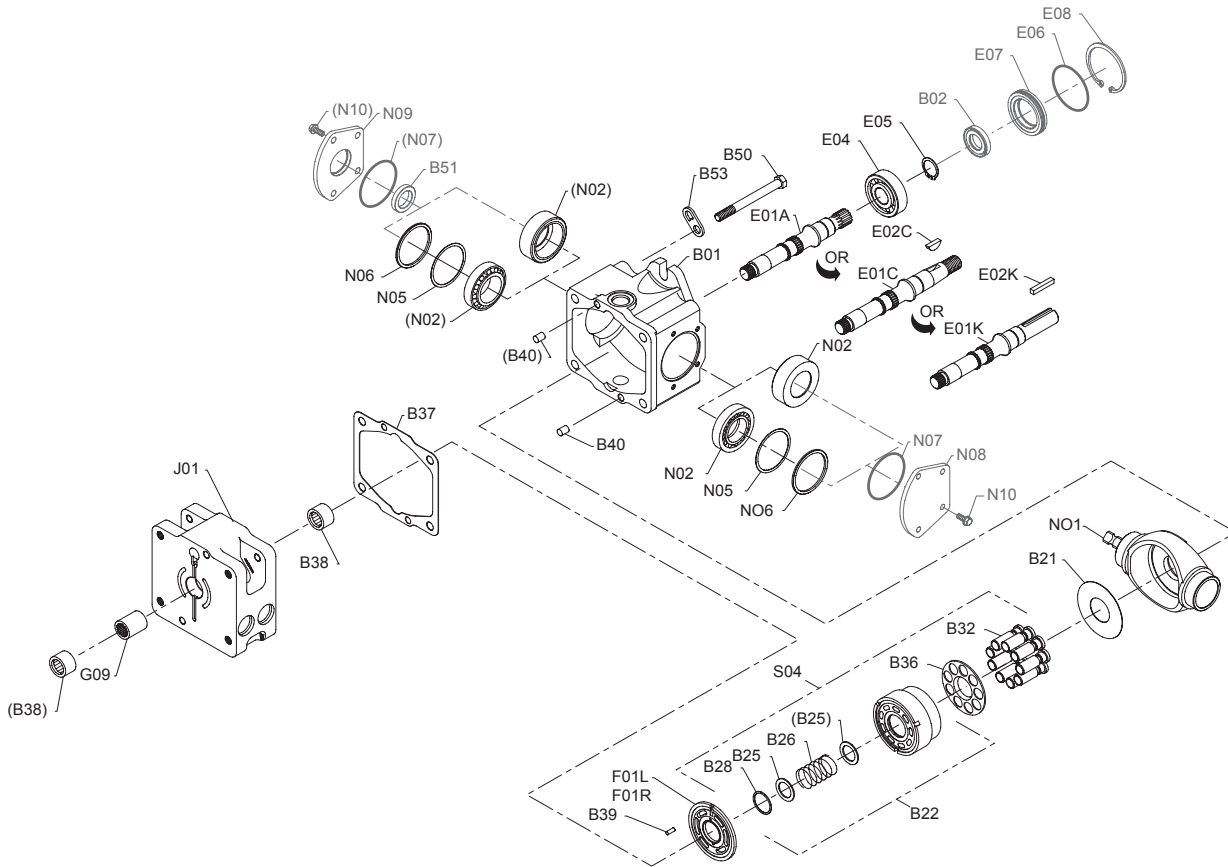

Exploded View of the M25 Variable Tandem Pump (Continued)

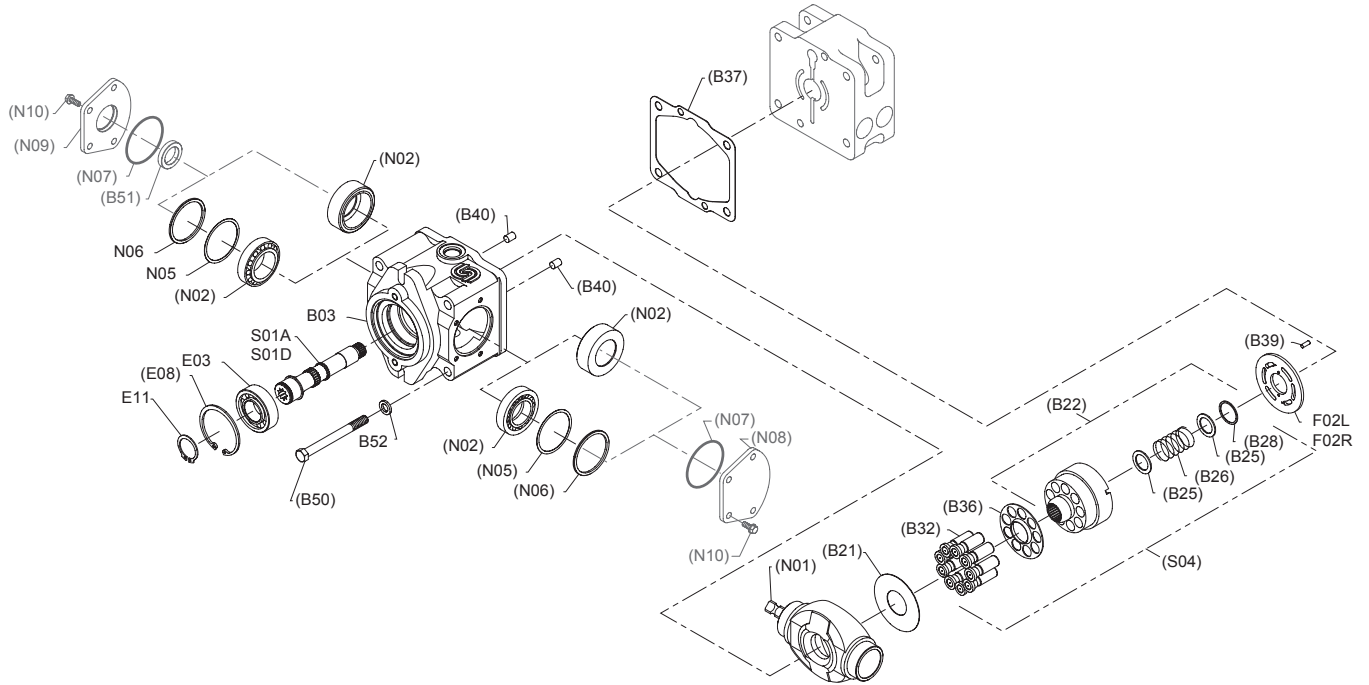

Exploded View of the M25 Variable Tandem Pump (Continued)

Item	Description	Qty	Item	Description	Qty
B01	HOUSING, VARIABLE (FRONT)	1	H07F	SPRING, HEL COMP (7 BAR/100PSI)	1
B02	SEAL, LIP	1	H07G	SPRING, HEL COMP (14 BAR/200PSI)	1
B03	HOUSING, VARIABLE (REAR)	1			
B21	PLATE, THRUST	2	M10A	POPPET-CHECK VALVE	1
B22	CYLINDER BLOCK KIT	2	M20A	POPPET-CHECK VALVE	1
B32	PISTON ASSY	18	M10B	VALVE, RELIEF	1
B36	RETAINER, SLIPPER	2	THRU		
B26	SPRING	2	M10M		
B25	WASHER	4	M20B	VALVE, RELIEF	1
B28	RING, RETAINING	2	THRU		
B37	GASKET, END CAP	2	M20M		
B38	BEARING, NEEDLE	2			
B39	PIN, ST HDLS	2	E01C	SHAFT, PUMP - TAPERED	1
B40	PIN	4	E02C	KEY	1
B42	PLUG, PLASTIC	1	E01K	SHAFT, PUMP - STR KEYED	1
B44	PLUG, PLASTIC	5	E02K	KEY, SQUARE	1
B45	PLUG, ST THD	3	E01S	SHAFT, PUMP - SPLINED 13T	1
B49	SCREW, DRIVE	2			
B50	SCREW, HEX HD	8	F01L	PLATE, VALVE (LH)	1
B51	SEAL, LIP	2	F02L	PLATE, VALVE (RH)	1
B52	WASHER	7	F01R	PLATE, VALVE (RH)	1
B53	LIFTING BRACKET	1	F02R	PLATE, VALVE (LH)	1
E03	BEARING, BALL	1			
E04	BEARING, BALL	1	S01A	SHAFT, VARIABLE - 9T AUX DRIVE	1
E05	RING, RETG	1	S01D	SHAFT, VARIABLE - 11T AUX DRIVE	1
E06	O-RING	1			
E07	CARRIER, SEAL	1	N01	SWASHPLATE, VARIABLE	2
E08	RING, INTERNAL RETAINING	2	N02	BEARING CARRIER ASSY	4
E11	RING, EXTERNAL RETAINING	1			
G09	COUPLING	1	N01	SWASHPLATE-VARIABLE	2
H01	PLUG ASSY, CHG RELIEF	1	N02	BEARING-TAPER ROLLER	4
H05	O-RING	1	N05	SHIM-TRUNNION	AR
H06	SHIM, CHG. RELIEF	1	N06	SPACER-TRUNNION	4
H08	POPPET, CHG.RELIEF	1			
J01	END CAP	1			
M01	PLUG, SPECIAL	4			
M02	O-RING	4			
M03	O-RING	4			
M04	SPRING, CONICAL COMP	4			
M05	RING, INTERNAL RETAINING	4			
N07	O-RING	4			
N08	COVER, TRUNNION (PLAIN)	2			
N09	COVER, TRUNNION	2			
N10	SCREW	16			
S14	O-RING	1			
S15	PLATE, COVER	1			
S16	SCREW, HEX HD	2			

Exploded View of the M25 Fixed Motor

The following information is for general parts identification ONLY. Refer to the applicable Service Parts List when ordering service parts.

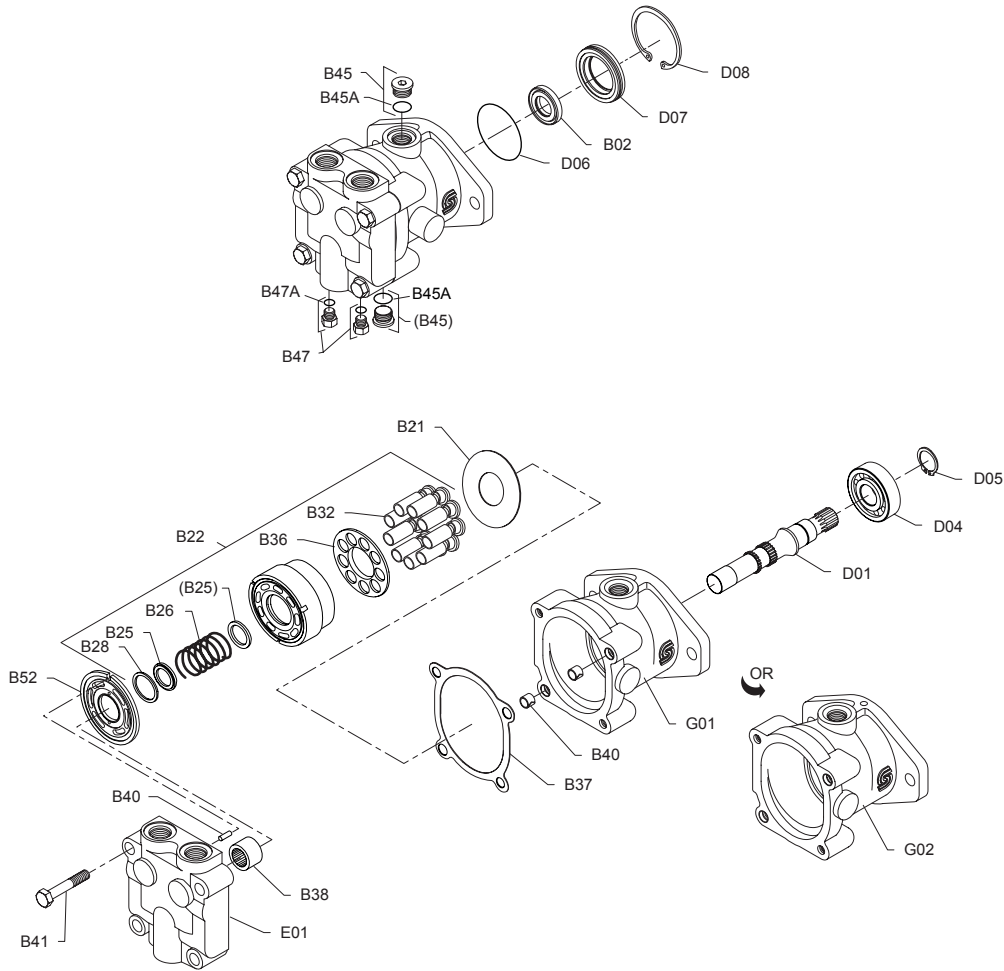

Name Plate

SAUER SAUERSUNDS	
Ames, Iowa, U.S.A.	Neumünster, Germany
Model Code	Typ
MMF025C	
A-A-G-A-B-	
NNN	
Model No.	Ident Nr
4253000	A 9329 67890
Serial No.	Fabr Nr
MADE IN U.S.A.	

Model Number — []
 Serial Number — []

Model Code — []
 Place of Manufacture — []

Exploded View of the M25 Fixed Motor (Continued)

Item	Description	Qty	Item	Description	Qty
B02	SEAL, LIP	1	D04	BEARING, BALL	1
B21	PLATE, THRUST	1	D05	RING, RETAINING	1
B22	CYLINDER BLOCK KIT-M25	1	D06	O-RING	1
B37	GASKET, END CAP-MF	1	D07	CARRIER, SEAL	1
B38	BEARING, NEEDLE	1	D08	RING, RETAINING	1
B39	PIN	1	D01	SHAFT-MF	1
B40	SLEEVE	2	E01	END CAP-MF	1
B41	SCREW, HEX HEAD	4	G01	HOUSING-MF	1
B45	PLUG	2	G02	HOUSING-MF (20CC)	1
B47	PLUG	2			
B52	PLATE, VALVE, MOTOR	1			
B53	BRACKET, LIFTING	1			

Exploded View of the M25 "U" Style Transmission

The following information is for general parts identification ONLY. Refer to the applicable Service Parts List when ordering service parts.

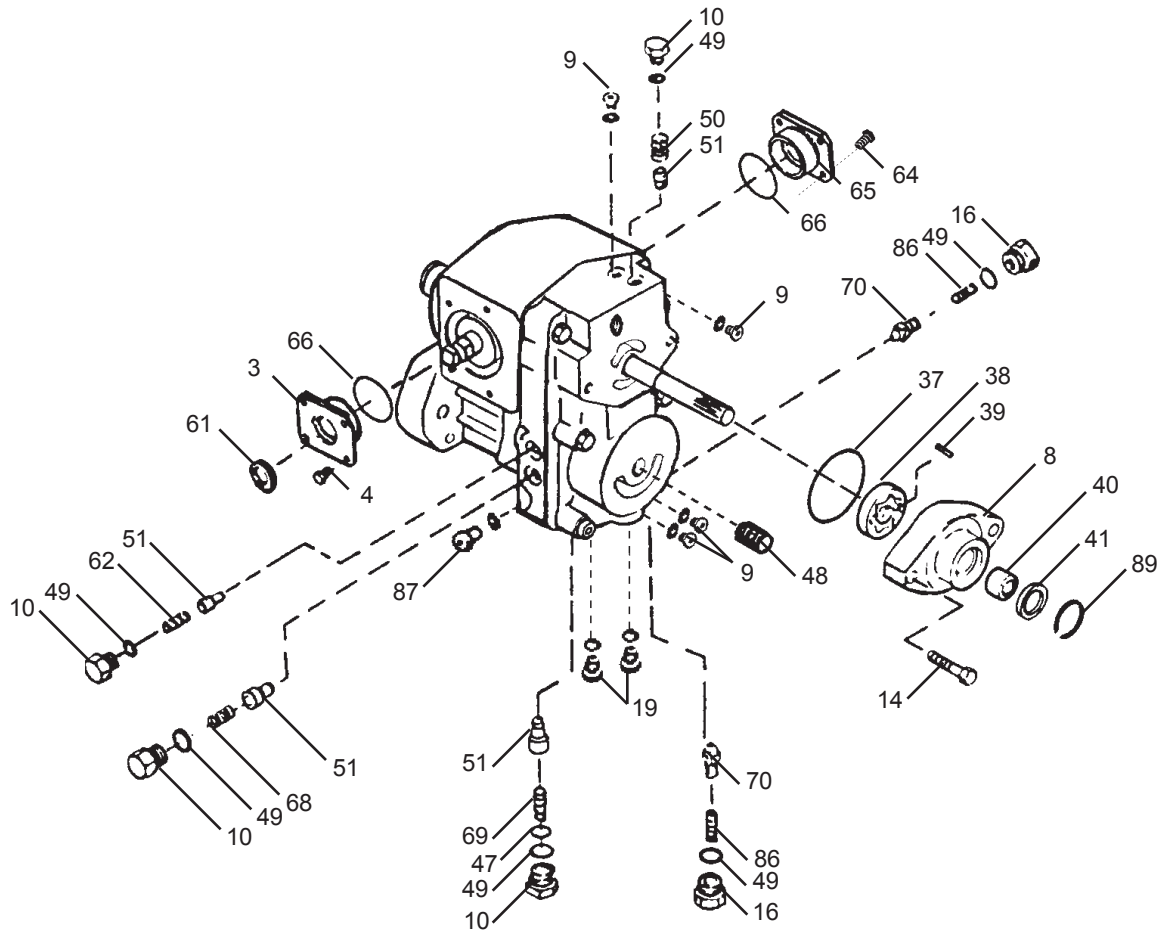

Name Plate

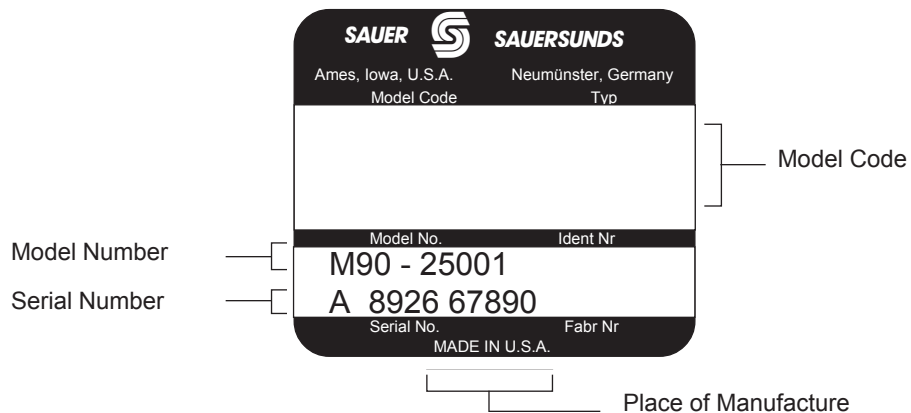

Exploded View of the M25 "U" Style Transmission (Continued)

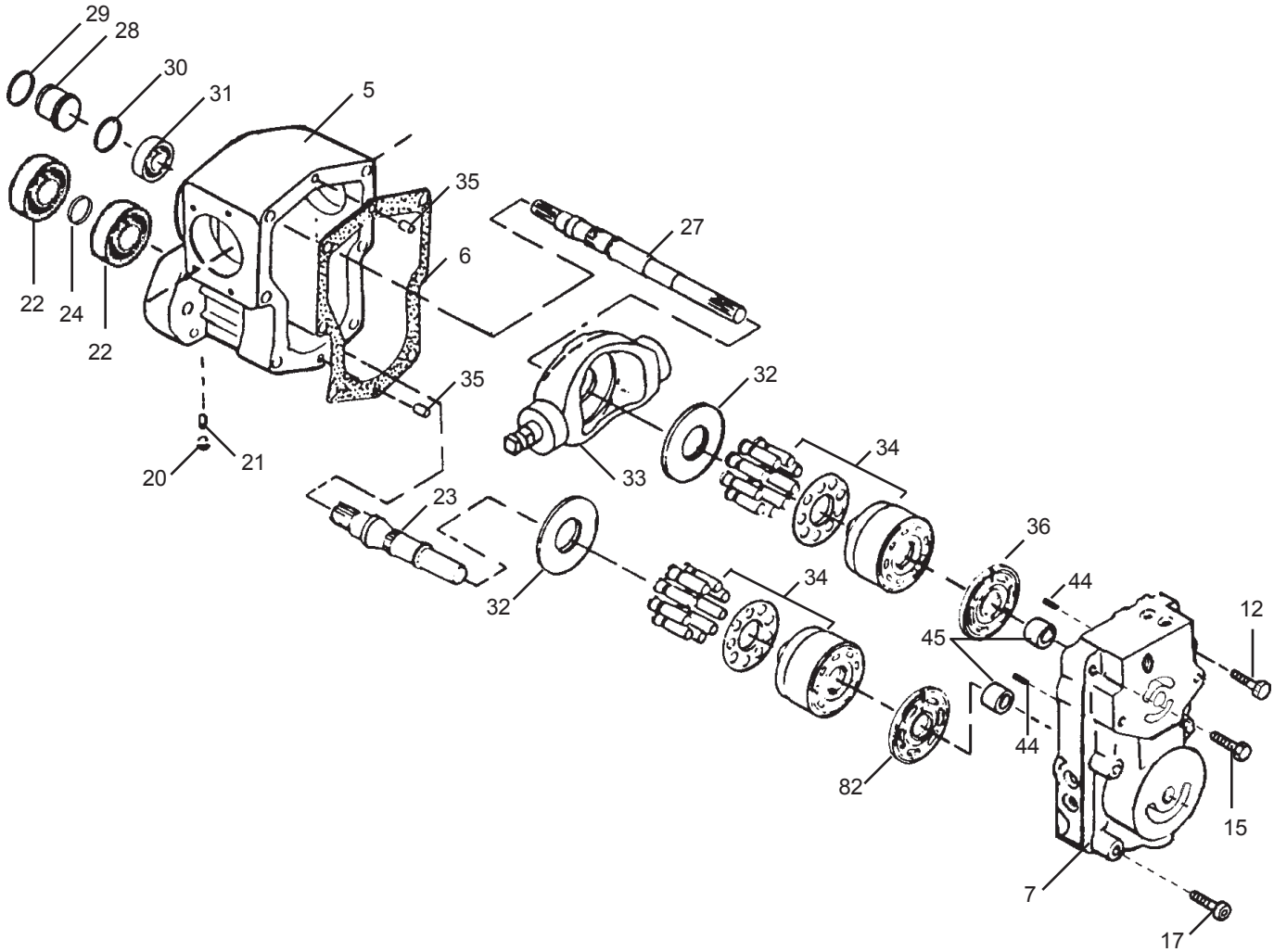

Exploded View of the M25 "U" Style Transmission (Continued)

Item	Description	Qty	Item	Description	Qty
0008	HOUSING, CHARGE PUMP	1	0061	SEAL, LIP	1
0004	SCREW	4	0062	SPRING	1
0005	HOUSING, TRANSMISSION	1	0064	SCREW	4
0006	GASKET, HOUSING	1	0066	O-RING	2
0007	CENTER SECTION	1	0068	SPRING	1
0008	HOUSING, CHARGE PUMP	1	0069	SPRING	1
0009	PLUG, ST THD	4	0082	PLATE, VALVE (MOTOR)	1
0010	PLUG	4	0084	PLUG	1
0012	SCREW, HEX HD	3	0085	SEAL	1
0013	PLUG, PLASTIC	2	0086	SPRING, CONICAL COMP	2
0014	SCREW, HEX HD	2	0087	PLUG, ST THD	1
0015	SCREW, HEX HD	1	0089	RING, RETAINING	1
0016	PLUG, SPECIAL	2			
0017	SCREW	2	0003L	TRUNNION KIT (SEAL SIDE)	1
0019	PLUG, ST THD	2	0065L	TRUNNION KIT (PLAIN)	1
0020	PLUG, PIPE	1	0003R	TRUNNION KIT (PLAIN)	1
0021	PIN	1	0065R	TRUNNION KIT (SEAL SIDE)	1
0022	BEARING, BALL	2			
0024	COLLAR	1	0036L	PLATE, VALVE - PUMP (LH)	1
0027	SHAFT, PUMP (U)	1	0036R	PLATE, VALVE - PUMP (RH)	1
0028	SEAL GUIDE	1			
0029	RING, RETG	1	0023	SHAFT, MOTOR - SPLINED 18T (U)	1
0030	O-RING	1	0023	SHAFT, MOTOR - SPLINED 17T (U)	1
0031	BEARING, BALL	1			
0032	PLATE, THRUST	2	0070	VALVE, CHECK/RELIEF	2
0033	SWASHPLATE, VARIABLE	1			
0034	CYLINDER BLOCK KIT	2			
	PISTON ASSEMBLY	18			
	RETAINER, SLIPPER	2			
	SPRING	2			
	WASHER	4			
	RING, RETAINING	2			
0035	PIN	2			
0037	O-RING	1			
0038	GEROTOR	1			
0039	PIN, ST HDLS	1			
0040	BEARING, NEEDLE	1			
0041	SEAL, LIP	1			
0042	SEAL, PACKAGING	1			
0043	NIPPLE	1			
0044	PIN, ST HDLS	2			
0045	BEARING, NEEDLE	2			
0046	PLUG, PLASTIC	1			
0047	SHIM	1			
0048	CAP, PLASTIC	1			
0049	O-RING	6			
0050	SPRING	1			
0051	VALVE, RELIEF	4			



Notes

Minor Repair and Replacement

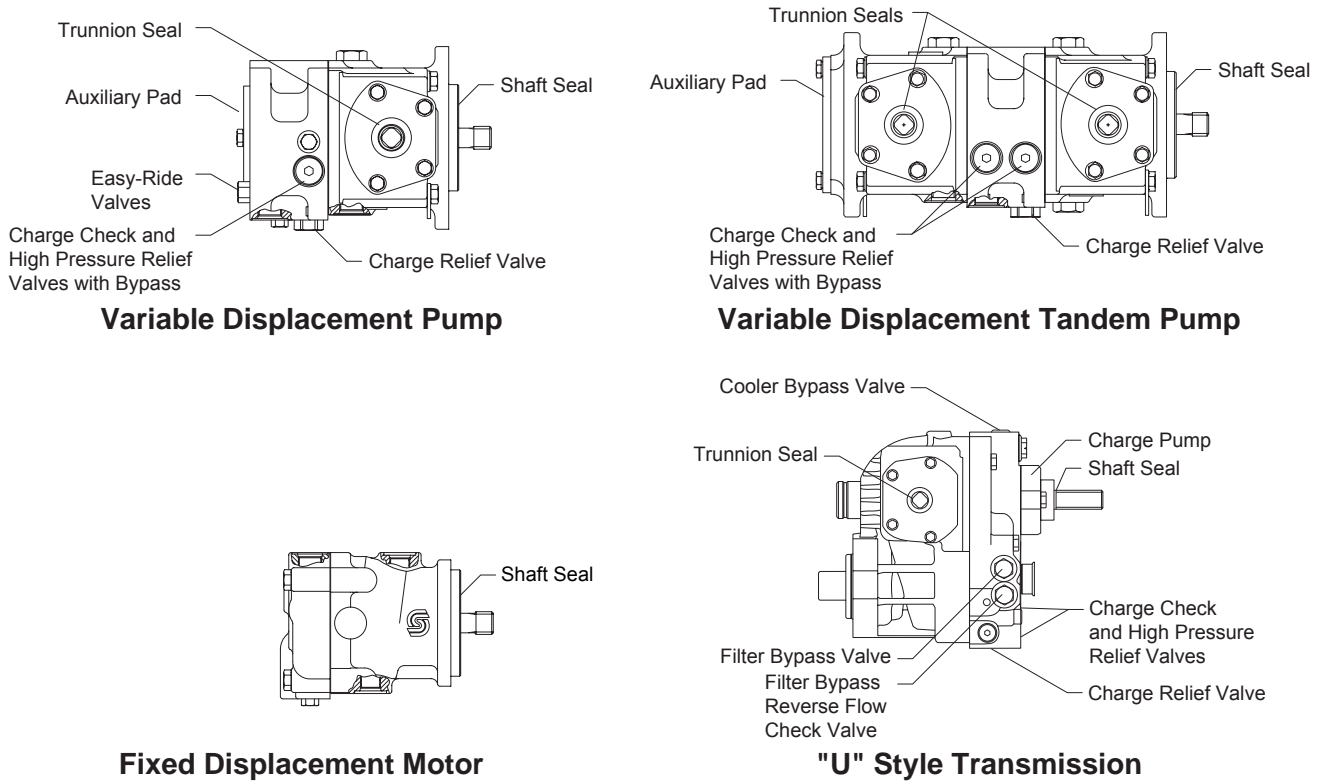

Fig. 50-1 - Minor Repairs

General

Minor Repairs may be performed, following the procedures in this section, without voiding the unit warranty.

Cleanliness is a primary means of assuring satisfactory transmission life, on either new or repaired units. Cleaning parts by using a clean solvent wash and air drying is usually adequate. As with any precision equipment, all parts must be kept free of foreign materials and chemicals.

Protect all exposed sealing surfaces and open cavities from damage and foreign material.

It is recommended that all gaskets and O-rings be replaced. Lightly lubricate all O-rings with clean petroleum jelly prior to assembly. All gasket sealing surfaces must be cleaned prior to installing new gaskets.

Minor Repair and Replacement - Pumps and Motors



40250017

Fig. 50-2 - Remove Seal Carrier Retaining Ring (PV / PT / MF)



40250018

Fig. 50-3 - Tapping Shaft with Soft Hammer to Remove Seal Carrier from Housing (PV / PT / MF)



40250019

Fig. 50-4 - Shaft Seal Removed (PV / PT / MF)



40250020

Fig. 50-5 - Install Seal Carrier with O-Ring (PV / PT / MF)

Shaft Seal Replacement - PV / PT / MF

Lip type shaft seals are used on the Series 40 - M25 variable pump, tandem pump, and fixed motor. These seals can be replaced without major disassembly of the unit.

Replacement of the shaft seal generally requires removal of the pump from the machine.

Remove the retaining ring from the housing.

NOTE: It may be necessary to hold inward pressure against the shaft to compress the cylinder block spring while removing the retaining ring.

After removing the retaining ring, the seal carrier will move out approximately 6 mm (1/4 in.) due to the cylinder block spring force on the shaft. Lightly tap the end of the shaft with a soft mallet until the seal carrier can be removed from the housing.

NOTE: After the seal carrier is removed, the shaft and bearing assembly are free in the housing. Do not remove shaft unless unit is positioned with the mounting flange UP. If the unit is positioned horizontally when the shaft is removed, the cylinder block could move out of place, making shaft installation difficult.

Remove the O-ring from the seal carrier.

Place the seal carrier in an arbor press and press out the old seal. An appropriately sized pipe spacer or socket wrench can be used as a press tool. Once removed, the seal is not reusable.

Inspect the seal carrier, the new seal, and the O-ring for damage. Inspect the sealing area on the shaft for rust, wear, or contamination. Polish the sealing area on the shaft if necessary.

Using the arbor press, press the new seal into the seal carrier. Be careful not to damage seal.

NOTE: The outside diameter of the new seal may be coated with a sealant (such as Loctite High Performance Sealant #59231) prior to installation.

Wrap the spline or key end of shaft with thin plastic to prevent damage to the seal lip during installation. Lubricate the inside diameter of the new seal with petroleum jelly.

Install the O-ring onto the seal carrier and lubricate with petroleum jelly.

Slide the seal carrier assembly over the shaft and into the housing bore. Hold inward pressure against the shaft to compress the cylinder block spring while pressing the seal carrier into position. Install the retaining ring.

Minor Repair and Replacement - Pumps and Motors (Cont.)

Trunnion Seal - PV / PT (Control Shaft Side)

Remove the control linkage from the swashplate control shaft. With a 7/16" or 1/2" wrench, remove the hex screws retaining the trunnion seal cover to the unit housing.

Remove the trunnion seal cover (with lip seal) and the O-ring. On units with tapered roller bearing trunnions, the bearing spacer and shims may be removed from the housing after removing the trunnion seal cover.

Place the seal cover in an arbor press and press out the old seal. Once removed, the seal is not reusable.

Inspect the seal cover for damage. Inspect the sealing area on the shaft for rust, wear, or contamination. Polish the sealing area on the shaft if necessary.

Using the arbor press, press the new seal into the seal cover from the inside until it bottoms in its bore. Be careful not to damage the seal or the cover.

NOTE: The outside diameter of the new seal may be coated with a sealant (such as Loctite High Performance Sealant #59231) prior to installation.

When reassembling units with tapered roller bearing trunnions, install the bearing shims and spacer into the housing in their original order. Install the O-ring onto the housing, and retain with petroleum jelly. Lubricate the inside diameter of the new seal with petroleum jelly.

Wrap the end of the swashplate control shaft with thin plastic to prevent damage to the seal lip during installation.

Slide the seal cover assembly over the swashplate control shaft and onto the housing. Install new hex head screws and torque to 15 to 20 Nm (11 to 15 lbf•ft). Reinstall the control linkage onto the swashplate control shaft.

Trunnion Cover - PV / PT (Plain)

The O-ring under the plain trunnion cover may be replaced after removing the hex screws (with a 7/16" or 1/2" hex wrench) and the cover. On units with tapered roller bearing trunnions, the bearing spacer and shims may be removed from the housing after removing the trunnion cover.

When reassembling units with tapered roller bearing trunnions, install the bearing shims and spacer into the housing in their original order. Install the O-ring onto the housing, and retain with petroleum jelly. Install the trunnion cover with the stamped identification mark ("O") out. Install new hex screws and torque to 15 to 20 Nm (11 to 15 lbf•ft).



40250021

Fig. 50-6 - Remove Trunnion Seal Cover (PV / PT)

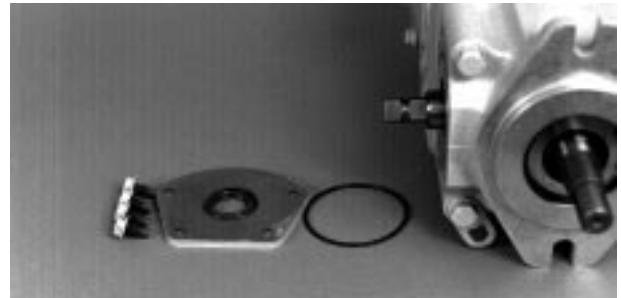

40250022

Fig. 50-7 - Trunnion Cover Components - Journal Bearings (PV / PT)

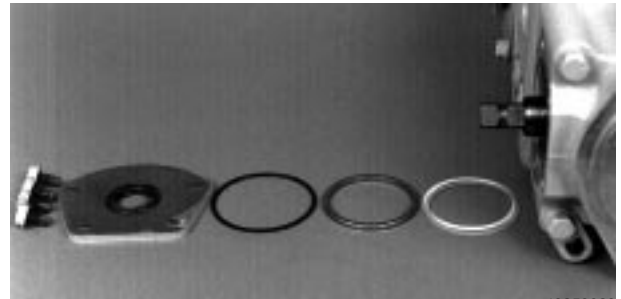

40250023

Fig. 50-8 - Trunnion Cover Components - Tapered Roller Bearings (PV / PT)



40250024

Fig. 50-9 - Torque Trunnion Seal Cover Screws (PV / PT)

Minor Repair and Replacement - Pumps and Motors (Cont.)



40250025

Fig. 50-10 - Remove Check and Relief Valve Plug (PV)



40250026

Fig. 50-11 - Remove Check and Relief Valve Plug (PT)



40250009

Fig. 50-12 - Check and Relief Valve Components (PV / PT)



40250027

Fig. 50-13 - Remove Charge Relief Valve Plug (PV)



40250028

Fig. 50-14 - Remove Charge Relief Valve Plug (PT)

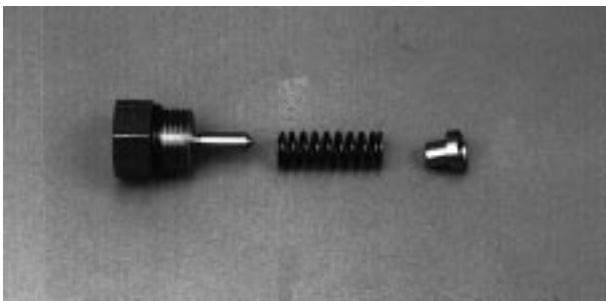

40250011

Fig. 50-15 - Charge Relief Valve Components (PV / PT)

Check and High Pressure Relief Valves - PV / PT

Remove the check and high pressure relief valves with a 5/16" internal hex wrench.

Remove the valve cartridge assembly from the pump end cap or center section. Inspect the valve and mating seat in the end cap or center section for damage or foreign material. It will be necessary to replace the end cap or center section if the seats are damaged.

The check poppet or relief valve is retained in the special plug by a circlip. The poppet or valve and check valve spring may be removed from the special plug by pulling out at a slight angle. When reassembling, install the check valve spring into the special plug with its larger diameter toward the plug, and snap the poppet or valve into position in the plug.

Reinstall the valve cartridges (with O-rings) into the center section. Torque the plugs to 41 to 68 Nm (30 to 50 lbf•ft).

CAUTION

The relief valves are factory set and should not be tampered with except for replacing the entire valve.

Charge Pressure Relief Valve - PV / PT

Remove the charge relief valve hex plug with a 1" wrench.

Remove the spring and poppet from the end cap or center section.

Do not alter the shims (which may be installed between the spring and valve plug) or interchange parts with another valve. Inspect the poppet and mating seat in the end cap for damage or foreign material.

Reinstall the poppet, spring, and plug (with shims and O-ring) into the center section. Torque the plug to 54 to 135 Nm (40 to 100 lbf•ft).

Minor Repair and Replacement - Pumps and Motors (Cont.)

Easy-Ride Valves - PV

Remove the Easy-Ride valve by removing the hex plug using a 11/16" hex wrench. Remove the spring and sleeve assembly with the poppet/piston. Remove the poppet/piston from the sleeve assembly.

Inspect the seat area in the end cap and the seat end of the poppet/piston for damage or foreign material. The poppet/piston must slide freely in the sleeve assembly. Inspect the spring for damage.

Reinstall the poppet/piston into the sleeve assembly. Install the sleeve assembly, spring, and plug with O-ring. Torque the plug to 20 to 47 Nm (15 to 35 lbf•ft).



Fig. 50-16 - Remove Easy Ride Valves (PV)

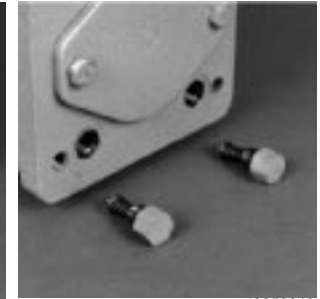

Fig. 50-17 - Easy-Ride Valves Removed (PV)



Fig. 50-18 - Easy-Ride Valve Components (PV)

Auxiliary Pump Mounting Pad - PV / PT

Remove the two (2) hex screws retaining the flange cover or auxiliary pump using a 9/16" wrench, and remove the cover or pump and the sealing ring.

On variable pumps, the drive coupling may be removed at this time. If a locating pin is present, it may be removed from the coupling at this time.

Pumps with steel pad covers use a single square cut sealing ring. If an auxiliary pump is installed, an O-ring seal must be installed on the pump pilot.

On variable pumps, reinstall the drive coupling with its locating pin, if used.

Reinstall the sealing ring and flange cover (with the identifying mark OUT) or auxiliary pump. Torque the screws to 27 to 34 Nm (20 to 25 lbf•ft).

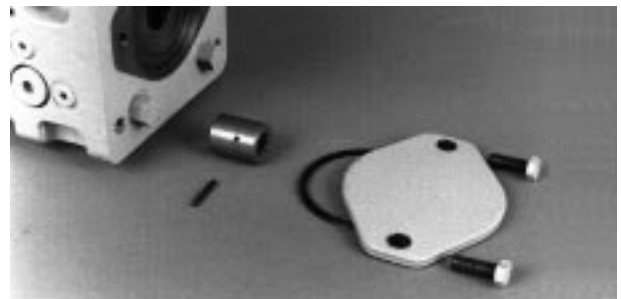

Fig. 50-19 - Auxiliary Pad Cover and Drive Coupling Removed (PV)



Fig. 50-20 - Pad Cover Removed (PT)

Minor Repair and Replacement - Pumps and Motors (Cont.)

Plug / Fitting Torques - PV / PT / MF

If any plugs or fittings are removed from the unit during servicing, they should be torqued as indicated in the following table.

Item	Torque
Pressure Gauge Ports (PV & PT) (7/16 —20 O-Ring)	12 Nm (9 lbf•ft)
Pressure Gauge Ports (MF) (9/16 —18 O-Ring)	20 Nm (15 lbf•ft)
Case Outlet Fittings / Housing Plugs (PV & PT) (7/8 — 14 O-Ring)	57 Nm (42 lbf•ft)
Case Outlet Fittings / Housing Plugs (MF) (3/4 — 16 O-Ring)	68 Nm (50 lbf•ft)
Charge Pressure Inlet / System Ports (7/8 — 14 O-Ring)	95 Nm (70 lbf•ft)

M25 Variable Pump, Tandem Pump, and Fixed Motor Conversion Information

Changing high pressure relief valves and charge pressure relief settings are considered to be Minor Repairs.

The auxiliary mounting flange drive spline on variable pumps may be changed by changing the coupling.

It is possible to change the variable pump, tandem pump, or fixed motor shaft without major disassembly of the unit. Remove the shaft seal. Then, with the unit positioned with the mounting flange UP, remove the shaft and bearing assembly. Install the replacement shaft and bearing assembly into the housing. Replace the shaft seal carrier.

The rear tandem pump section shaft (with auxiliary mounting flange drive spline) may be changed in a similar manner.

CAUTION

Do not remove both the front and rear pump section shafts from tandem pumps at the same time. The coupling between the pump sections will move out of position, requiring disassembly of the unit.

Changing the direction of pump rotation or changing the location of the control trunnions in the housing(s) requires major disassembly of the unit.

Minor Repair and Replacement - “U” Style Transmission

Shaft Seal Replacement

If the shaft seal is accessible with the charge pump installed on the transmission, proceed as follows:

Remove the seal retaining ring (used on later production units) from the charge pump cover.

Carefully remove the seal from the bore in the charge pump cover. The face of the seal may be punctured with a sharp instrument (such as a screwdriver) to aid in prying the seal out, or a slide hammer type puller may be used to remove the seal. Care must be taken so as not to damage the charge pump cover or shaft. Once removed, the seal is not reusable.

Inspect the charge pump cover, the new seal, and the shaft for damage. Inspect the sealing area on the shaft for rust, wear, or contamination. Polish the sealing area on the shaft if necessary.

Lubricate the inside diameter of the new seal with petroleum jelly. Wrap the spline end of the shaft with thin plastic to prevent damage to the seal lip during installation.

NOTE: The outside diameter of the new seal may be coated with a sealant (such as Loctite High Performance Sealant #59231) prior to installation.

Press the new seal into the charge pump cover, being certain the seal is perpendicular to the shaft. Be careful not to damage seal. On earlier production units, the outer face of the seal should be located from 1.42 to 2.44 mm (0.056 to 0.096 in.) below the outer surface of the charge pump cover. On later production units, the seal must be pressed in far enough to allow the retaining ring to be installed.

Install the seal retaining ring (used on later production units) into the charge pump cover.

If the shaft seal is not accessible with the charge pump cover installed on the transmission, proceed as follows:

Remove the charge pump cover from the transmission as outlined in the “Charge Pump” section.

Carefully remove the seal from the bore in the charge pump cover. Once removed, the seal is not reusable.

Inspect the charge pump cover, the new seal, and the shaft for damage. Inspect the sealing area on the shaft for rust, wear, or contamination. Polish the sealing area on the shaft if necessary.

Install the new seal into the charge pump cover, as previously described.

Lubricate the inside diameter of the new seal with petroleum jelly, Reinstall the charge pump cover as outlined in the “Charge Pump” section, being careful not to damage the seal on the shaft splines.

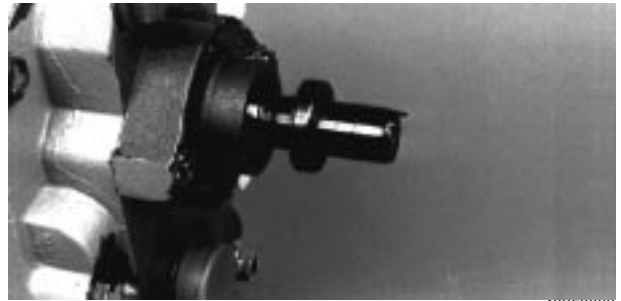

40250033

Fig. 50-21 - Installing Shaft Seal with Charge Pump Installed (U)



40250006

Fig. 50-22 - Shaft Seal Installed (U)



40250034

Fig. 50-23 - Installing Charge Pump Cover with Shaft Seal (U)

Minor Repair and Replacement - "U" Style Transmission (Continued)



Fig. 50-24 - Remove Trunnion Seal Cover (U)

40250035

Trunnion Seal Cover (Control Shaft Side)

Remove the control linkage from the swashplate control shaft. With a 3/8" wrench, remove the hex tapping screws retaining the trunnion seal cover and bearing carrier to the unit housing.

Remove the trunnion seal cover and bearing carrier (with lip seal) and the O-ring.

Place the seal cover and bearing carrier in an arbor press and press out the old seal. Once removed, the seal is not reusable.

Inspect the seal cover and bearing carrier for damage. Inspect the sealing area on the shaft for rust, wear, or contamination. Polish the sealing area on the shaft if necessary.

Using the arbor press, press the new seal into the seal cover and bearing carrier until the outside face of the seal is flush with the outer surface of the cover. Be careful not to damage the seal.

NOTE: The outside diameter of the new seal may be coated with a sealant (such as Loctite High Performance Sealant #59231) prior to installation.

Install the O-ring onto the bearing carrier, and retain with petroleum jelly. Lubricate the inside diameter of the new seal with petroleum jelly.

Wrap the end of the swashplate control shaft with thin plastic to prevent damage to the seal lip during installation.

Slide the seal cover and bearing carrier assembly over the swashplate control shaft and onto the housing. Install the hex head tapping screws and torque to 8 to 12 Nm (6 to 9 lbf•ft). Reinstall the control linkage onto the swashplate control shaft.



Fig. 50-25 - Trunnion Cover Components - Journal Bearings (U)

40250036

Trunnion Cover (Plain)

The O-ring under the plain trunnion cover may be replaced after removing the hex tapping screws (with a 3/8" hex wrench) and the cover and bearing carrier.

Install the O-ring onto the bearing carrier, and retain with petroleum jelly. Install the trunnion cover and bearing carrier. Install the hex head tapping screws and torque to 8 to 12 Nm (6 to 9 lbf•ft).



Fig. 50-26 - Install Trunnion Seal Cover (U)

40250037



Fig. 50-27 - Torque Trunnion Seal Cover Screws (U)

40250038

Minor Repair and Replacement - "U" Style Transmission (Continued)

Check and High Pressure Relief Valves

Remove the check and high pressure relief valve plugs with a 7/8" hex wrench.

Remove the springs and valve cartridges from the center section. Inspect the valves and mating seats in the center section for damage or foreign material. It will be necessary to replace the center section if the seats are damaged.

Several designs of the charge check and high pressure relief valve have been used in the M25U transmission. Do not attempt to mix different vintage parts.

The valve cartridge, spring, plug, and transmission center section were changed at date code 87-39, and are not individually interchangeable with earlier design parts.

NOTE: If the center section must be replaced on a unit with a date code prior to 87-39, the latest design charge check and high pressure relief valves must also be installed. Refer to the appropriate Service Parts Manual for more information.

Reinstall the valve cartridges into the center section. Install the check valve springs with their larger diameter toward the plugs.

Reinstall the plugs (with O-rings) into the center section. Torque the plugs to 41 to 95 Nm (30 to 70 lbf•ft).

CAUTION

The relief valves are factory set and should not be tampered with except for replacing the entire valve.

Charge Pressure Relief Valve

Remove the charge relief valve hex plug with a 7/8" wrench.

Remove the spring and poppet from the center section.

Do not alter the shims (which may be installed between the spring and plug) or interchange parts with another valve. Inspect the poppet and mating seat in the end cap for damage or foreign material.

Reinstall the poppet, spring, and plug (with shims and O-ring) into the center section. Torque the plug to 41 to 95 Nm (30 to 70 lbf•ft).



Fig. 50-28 - Remove Check and Relief Valve Plug "A" (U)

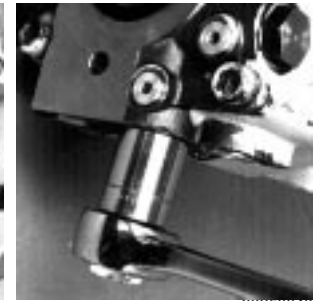

Fig. 50-29 - Remove Check and Relief Valve Plug "B" (U)



Fig. 50-30 - Check / High Pressure Relief Valves (U)



Fig. 50-31 - Remove Charge Relief Valve Plug (U)



Fig. 50-32 - Charge Relief Valve Components (U)

Minor Repair and Replacement - "U" Style Transmission (Continued)



90250042

Fig. 50-33 - Remove Heat Exchanger Bypass Valve Plug (U)

Heat Exchanger Bypass Valve

Remove the heat exchanger bypass valve plug with a 7/8" hex wrench.

Remove the spring and poppet from the center section.

Do not interchange parts with another valve.

Earlier production transmissions use a spring in the heat exchanger bypass valve which is identified by a yellow dye mark and requires a force of approximately 22 N (5.5 lbf) to compress it to a length of 45.7 mm (1.28 inches).

Later production transmissions use a spring in the heat exchanger bypass valve which is identified by a red dye mark and requires a force of approximately 10 N (2.2 lbf) to compress it to a length of 1.28 inches (45.7 mm).

Inspect the poppet and mating seat in the end cap for damage or foreign material.

Reinstall the poppet, spring, and plug (with O-ring) into the center section. Torque the plug to 41 to 95 Nm (30 to 70 lbf•ft).



90250014

Fig. 50-34 - Heat Exchanger Bypass Valve (U)

Filter Bypass Valve

Remove the filter bypass valve hex plug with a 7/8" wrench.

Remove the spring and poppet from the center section.

Do not interchange parts with another valve. The spring used in the filter bypass valve is identified by a red dye mark, and requires a force of approximately 10 N (2.2 lbf) to compress it to a length of 45.7 mm (1.28 inches). Inspect the poppet and mating seat in the end cap for damage or foreign material.

Reinstall the poppet, spring, and plug (with O-ring) into the center section. Torque the plug to 41 to 95 Nm (30 to 70 lbf•ft).



90250043

Fig. 50-35 - Remove Filter Bypass Valve Plug (U)



90250015

Fig. 50-36 - Filter Bypass Valve (U)

Minor Repair and Replacement - "U" Style Transmission (Continued)

Filter Bypass Reverse Flow Check Valve

Remove the reverse flow check valve plug with a 7/8" hex wrench.

Remove the spring and poppet from the center section.

Do not interchange parts with another valve. The spring used in the reverse flow check valve is identified with a blue dye mark and requires a force of approximately 1.3 N (0.3 lbf) to compress it to a length of 45.7 mm (1.28 inches). Inspect the poppet and mating seat in the end cap for damage or foreign material.

Reinstall the poppet, spring, and plug (with O-ring) into the center section. Torque the plug to 41 to 95 Nm (30 to 70 lbf•ft).



40250044

Fig. 50-37 - Remove Filter Bypass Reverse Flow Check Valve Plug (U)



40250016

Fig. 50-38- Filter Bypass Reverse Flow Check Valve (U)

Integral Charge Pump

Remove the two (2) screws retaining the charge pump cover, using a 9/16" hex wrench. Remove the charge pump assembly.

Remove the gerotor drive pin from the groove in the shaft.

Remove the gerotor assembly from the charge pump cover. Remove the retaining ring (if used) and the shaft seal from the cover.

Inspect all parts that are to be reused. If either of the gerotor assembly parts needs to be replaced, they must both be replaced. Always replace the O-rings.



40250045

Fig. 50-39 - Remove Charge Pump Cover Screws (U)



40250034

Fig. 50-40 - Remove Charge Pump Assembly (U)

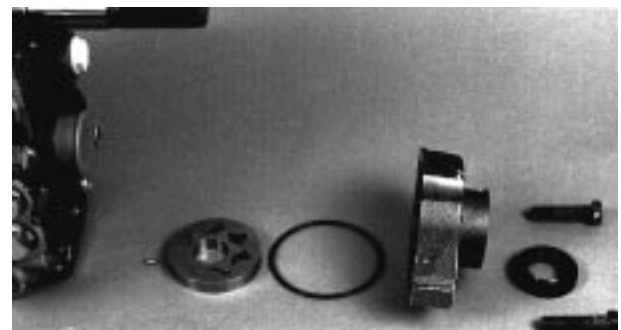

40250046

Fig. 50-41 - Charge Pump Components (U)

Minor Repair and Replacement - "U" Style Transmission (Continued)



Fig. 50-42 - Bearing Installed in Charge Pump Cover (U)



Fig. 50-43 - Install Gerotor Drive Pin (U)

Inspect the shaft bearing in the charge pump cover for wear or damage. If replacement is necessary, remove the needle bearing from the cover using a suitable puller. Press a new needle bearing into the cover using a suitable press pin. When installed correctly, the bearing cage will be flush to 0.51 mm (0.02 in.) below the surface of the seal counterbore in the front of the cover.

CAUTION

When installing the needle bearing, the printed (numbered) end of the bearing cage must face the press pin.



Fig. 50-44 - Install Gerotor Assembly in Pump Cover (U)



Fig. 50-45 - Install Charge Pump Assembly (U)

Install the gerotor drive pin in the groove in the drive shaft, and retain with petroleum jelly.

Prior to assembly, lubricate the gerotor assembly with clean hydraulic oil. Install the gerotor assembly into the charge pump cover. Install the O-ring and retain with petroleum jelly.

NOTE: The charge pump rotation is determined by the position of the charge pump cover on the transmission center section.

Install the charge pump assembly over the drive shaft and onto the transmission center section, orienting it for the proper input shaft rotation direction. Be certain the gerotor engages the drive pin in the shaft.

The flat on the charge pump cover should be located away from the heat exchanger ports for clockwise (CW) input rotation, and next to the heat exchanger ports for counterclockwise (CCW) input rotation.

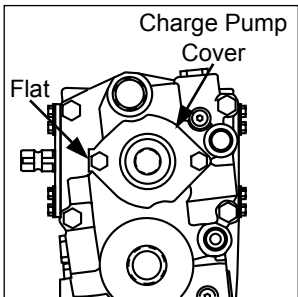

Fig. 50-46 - Orienting Charge Pump Cover (CW) (U)

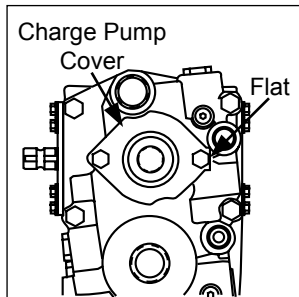

Fig. 50-47 - Orienting Charge Pump Cover (CCW) (U)

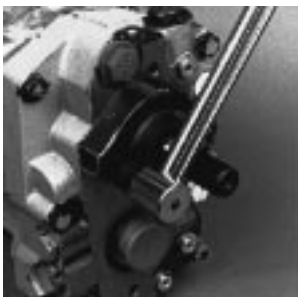

Fig. 50-48 - Torquing Charge Pump Cover Screws (U)



Fig. 50-49 - Installing Shaft Seal (U)

Torque the charge pump cover screws to 37 to 50 Nm (27 to 37 lbf•ft).

Install a new shaft seal as outlined in the "Shaft Seal Replacement" section.

Minor Repair and Replacement - "U" Style Transmission (Continued)

Plug / Fitting Torques

If any plugs or fittings are removed from the unit during servicing, they should be torqued as indicated in the following tables.

Item	Torque
Charge Pump Inlet (1-1/16 — 12 O-Ring)	95 to 230 Nm (70 to 170 lbs•ft)
Oil Cooler Ports (3/4 — 16 O-Ring)	41 to 95 Nm (30 to 70 lbsf•ft)
Pressure Gauge Ports (7/16 — 20 O-Ring)	11 to 14 Nm (8 to 10 lbsf•ft)
Loop Passage Plugs (3/4 — 16 O-Ring)	41 to 95 Nm (30 to 70 lbsf•ft)
Loop Passage Plug (9/16 — 16 O-Ring)	20 to 27 Nm (15 to 20 lbsf•ft)

M25 "U" Style Transmission Conversion Information

Changing high pressure relief valves and charge pressure relief settings are considered to be Minor Repairs.

Changing the direction of rotation or changing the location of the control trunnion in the housing requires major disassembly of the unit.

Notes

Major Repair - Variable Pump

General

The following procedures are for the complete disassembly and reassembly (Major Repair) of the Series 40 - M25 Variable Pump.

Cleanliness is a primary means of assuring satisfactory hydraulic pump life, on either new or repaired units. Cleaning parts by using a clean solvent wash and air drying is usually adequate. As with any precision equipment, all parts must be kept free of foreign materials and chemicals. Protect all exposed sealing surfaces and open cavities from damage and foreign material.

During the assembly of the Series 40 - M25 variable pump, all surfaces which have relative motion between two parts should be coated with a film of clean hydraulic oil. This will assure that these surfaces will be lubricated during start-up.

It is recommended that all O-rings and gaskets be replaced. Lightly lubricate all O-rings with clean petroleum jelly prior to assembly. All gasket sealing surfaces must be cleaned prior to installing new gaskets.

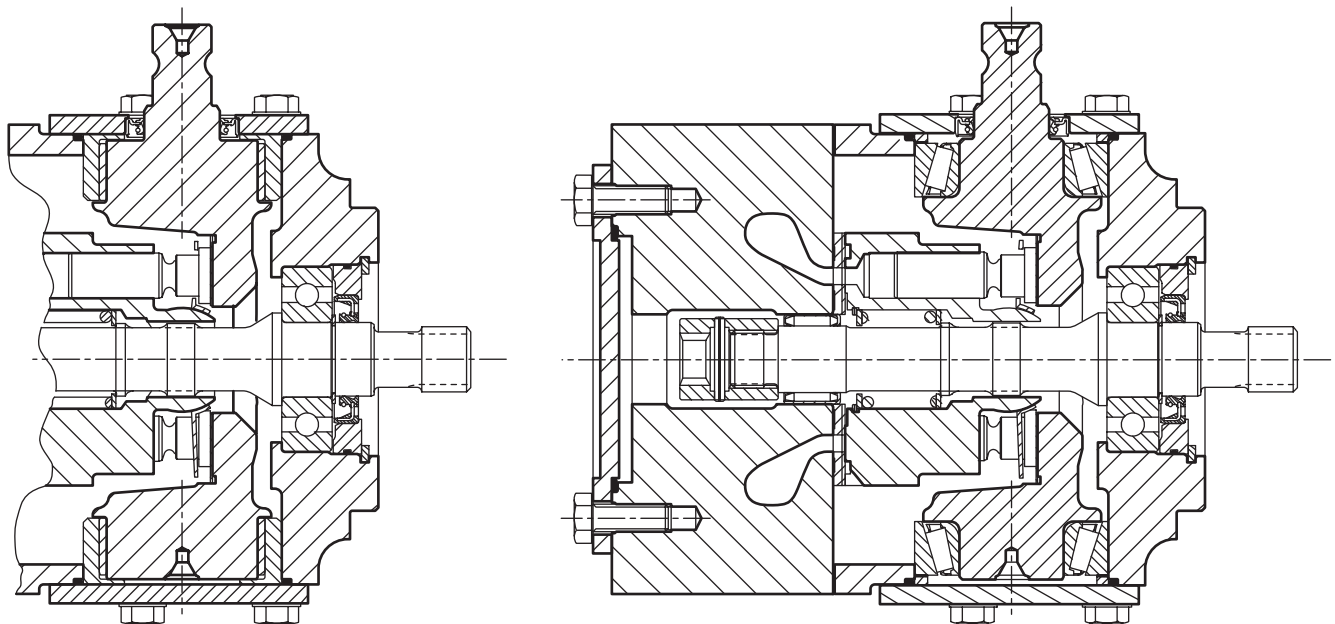

With Journal Trunnion Bearings

With Tapered Roller Trunnion Bearings

Fig. 61-1 - Cross Section View of Series 40 - M25 Variable Displacement Pump

40250053

Major Repair - Variable Pump (Continued)



Fig. 61-2 - Remove Housing Screws



Fig. 61-3 - Remove End Cap

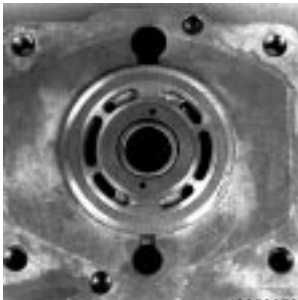

Fig. 61-4 - Remove Valve Plate



Fig. 61-5 - Remove Cylinder Block



Fig. 61-6 - Cylinder Block Kit Disassembled



Fig. 61-7 - Remove Thrust Plate



Fig. 61-8 - Remove Shaft Seal Cover



Fig. 61-9 - Remove Shaft and Bearing

Disassembly Procedures for Variable Displacement Pump

Prior to performing Major Repairs on the Series 40 - M25 Variable Pump, remove the external components as described in the "Minor Repair" section. These include the following:

- Auxiliary Mounting Pad Cover and Coupling
- Easy-Ride Valves (Where Applicable)
- Charge Relief Valve
- Charge Check / High Pressure Relief Valves

After removal of these components, mark the orientation of the pump housing and end cap, and remove the four (4) screws (using a 5/8" hex wrench) and washers which retain the housing to the end cap.

Remove the housing from the end cap and valve plate. Do not allow the valve plate to fall from the end cap. Remove the gasket and alignment pins from the end cap.

Carefully remove the valve plate from the end cap. It may be necessary to pry the valve plate off with a small screwdriver.

CAUTION

Caution must be exercised to prevent damage to the valve plate and end cap surfaces.

Remove the valve plate pin from the end cap.

Lay the pump housing on its side and remove the cylinder block from the housing.

Remove the slipper guide and the piston assemblies from the cylinder block.

Using an O-ring pick or wire, remove the thrust plate from the swashplate.

Remove the retaining ring and remove the shaft seal cover per the instructions in the "Minor Repair" section.

Remove the drive shaft and bearing assembly from the housing.

Major Repair - Variable Pump (Continued)

Remove the retaining ring and press the shaft out of the bearing.

Mark the positions of the trunnion seal cover and trunnion cover on the housing. With a 7/16" or 1/2" hex wrench, remove the hex screws retaining the trunnion seal cover and trunnion cover to the housing.

Remove the trunnion seal cover assembly and trunnion cover from the housing. Remove the O-rings.

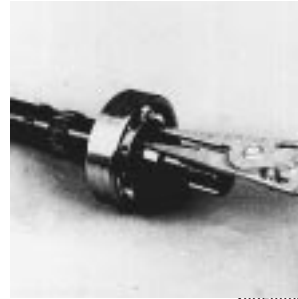

40250062

Fig. 61-10 - Remove Bearing from Shaft



40250063

Fig. 61-11 - Remove Trunnion Covers

On units with journal bearings, remove the swashplate bearing assemblies from the housing and swashplate. The assemblies are a slip fit in the housing.

On units with tapered roller bearings, remove the bearing spacers and shims from the housing. Do not alter the shim thickness. Remove the bearing cups from the housing and the bearing cones from the swashplate. The cups and cones are a slip fit in the housing and on the swashplate.

Tilt and lift the swashplate from the housing.



40250064

Fig. 61-12 - Swashplate Bearing Components



40250065

Fig. 61-13 - Remove Swashplate

Major Repair - Variable Pump (Continued)

Reconditioning and Replacement of Parts

After disassembly all parts should be thoroughly cleaned in a suitable solvent. Replace all O-rings, gaskets, and seals.

Inspect all parts for damage, nicks, or unusual wear patterns. Replace all parts having unusual or excessive wear or discoloration.

Cracks are not allowed in any surface of the valve plate or cylinder block. The running and sealing surfaces of the valve plate and cylinder block must be flat and free of nicks and burrs. Replace valve plates or cylinder blocks that show evidence of metal transfer, wear, or erosion on the running surface.

If scratches, which can be felt with a fingernail or pencil lead, are found on the bronze surface of the valve plate or the running surface of the cylinder block, polish or replace the parts.

Inspect the needle bearing in the end cap. If replacement is necessary, remove the shaft needle bearing using a suitable puller. Do not damage the valve plate surface of the end cap.

Press a new needle bearing into the end cap using a suitable press pin. When installed correctly, the bearing cage will protrude from 2.0 to 2.5 mm (0.08 to 0.10 in.) from the surface of the end cap to serve as a pilot for the valve plate.



Fig. 61-14 - Needle Bearing Installed in End Cap

CAUTION

When installing the needle bearing, the printed (numbered) end of the bearing cage must face the press pin.

Replace any bearing cups or cones that show spalling or wear. Tapered roller bearing cups and cones should be kept together and not mixed. If replacement is necessary, always replace both the cup and the cone.

Replace all piston assemblies if brass slippers are scored or excessively rounded at the edges.

Compress the cylinder block spring and remove the spiral retaining ring, outer washer, spring, and inner washer. Reassemble in the reverse order.

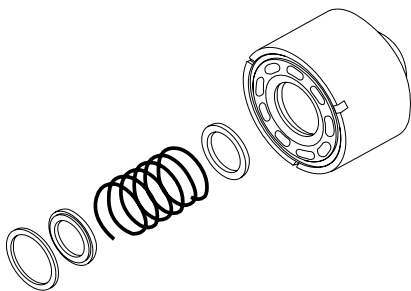

Fig. 61-15 - Cylinder Block Spring Components

Major Repair - Variable Pump (Continued)

Assembly Procedures for Variable Displacement Pump

Clean and lightly oil parts prior to assembling the pump. Be sure to torque all threaded parts to recommended torque levels.

CAUTION

Most parts have critical, high tolerance surfaces. Caution must be exercised to prevent damage to these surfaces during assembly. Protect exposed surfaces, openings, and ports from damage and foreign material.

Begin the assembly of the pump by installing the swashplate in the housing. Make sure the swashplate control shaft is located on the correct side of the housing (note the marks made during disassembly).

For units with journal type swashplate bearings, install the bearings into the housing and onto the swashplate trunnions.

For units with tapered roller type swashplate bearings, install the bearing cones onto the swashplate trunnions and install the bearing cups into the housing.

If the housing, swashplate, or swashplate bearings were not replaced on units with tapered roller type swashplate bearings, the original shims will be reinstalled between the bearing cups and the bearing spacers. If any of these parts were replaced, the following procedure must be performed to determine the proper shim thickness.

1. Install the bearing spacers into the housing with no shims.
2. Install the trunnion covers onto the housing. Install the hex head screws and tighten.
3. Install a magnetic base dial indicator onto the seal cover and read the swashplate end play while moving the swashplate back and forth by hand. Add shims to provide 0.05 to 0.1 mm (0.002 to 0.004 in.) preload on the swashplate bearings.
For example, if the indicator reads 1.02 mm (0.040 in.) end play when moving the swashplate back and forth, shims of 1.07 to 1.12 mm (0.042 to 0.044 in.) total thickness should be installed between the bearing cups and the spacers. Refer to the appropriate Service Parts Manual for available shim thicknesses and part numbers.
4. Remove the trunnion covers from the housing. Remove the bearing spacers.



Fig. 61-16 - Install Swashplate

40250065



Fig. 61-17 - Install Trunnion Bearings (Journal)

40250067



Fig. 61-18 - Install Trunnion Bearings (Tapered Roller)

40250068

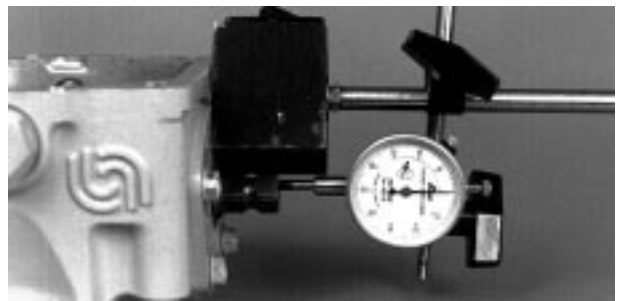

Fig. 61-19 - Check Swashplate End Play (Tapered Roller)

40250069

Major Repair - Variable Pump (Continued)



40250023

Fig. 61-20 - Trunnion Cover Components (Tapered Roller)

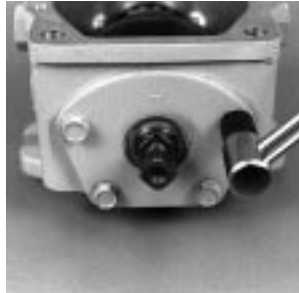

40250070

Fig. 61-21 - Torque Trunnion Cover Screws

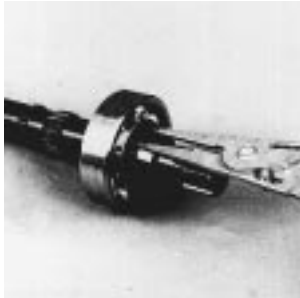

40250062

Fig. 61-22 - Install Shaft Bearing Retaining Ring

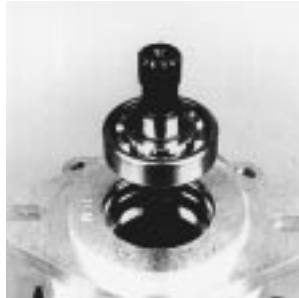

40250061

Fig. 61-23 - Install Shaft and Bearing into Housing



40250071

Fig. 61-24 - Install Shaft Seal Cover



40250059

Fig. 61-25 - Install Thrust Plate



40250072

Fig. 61-26 - Install Piston Assemblies into Cylinder Block



40250057

Fig. 61-27 - Install Cylinder Block Kit

Using an arbor press, press a new seal into the trunnion seal cover. Be careful not to damage the seal.

For units with tapered roller type swashplate bearings, install the the trunnion shims into the housing next to the swashplate bearing cups, and retain with petroleum jelly. Locate the shims so that there is no more than 0.20 mm (0.008 in.) difference in shim thickness from one side of the swashplate to the other. Install the trunnion bearing spacers.

Install the O-rings and trunnion covers, as described in the "Minor Repair" section of the Service Manual. Install new hex head screws and torque to 15 to 20 Nm (11 to 15 ft.lbsf.).

NOTE: When units with tapered roller type swashplate bearings are properly assembled, a torque of 0.56 to 2.26 Nm (5 to 20 lbsf•in) will be required to rotate the swashplate.

Using caution to not damage the sealing surface, press the ball bearing onto the drive shaft. Install the bearing retaining ring onto the shaft.

Install the drive shaft and bearing into the housing.

Install the input shaft seal, seal cover, and O-ring, as described in the "Minor Repair" section of the Service Manual. Install the retaining ring.

Coat the thrust plate with petroleum jelly and install onto the swashplate. The thrust plate is reversible.

Assemble the piston assemblies into the slipper guide. Lubricate the pistons and cylinder block bores. Install the assembled guide and pistons into the cylinder block by inserting the piston assemblies into the cylinder block bores. The pistons and bores are not selectively fitted, therefore no specific piston and bore orientation is required.

Lay the pump housing on its side and install the cylinder block kit into the housing.

Major Repair - Variable Pump (Continued)

Install the valve plate locating pin into the end cap.

Coat the back (steel side) of the valve plate with petroleum jelly to hold it in position, and install the valve plate onto the end cap, with the bronze face visible. The notch on the valve plate must engage the locating pin. Be certain the correct valve plate is installed on the end cap for the pump rotation and configuration. Refer to the appropriate Service Parts Manual for more information.



Fig. 61-28 - Install Valve Plate Pin

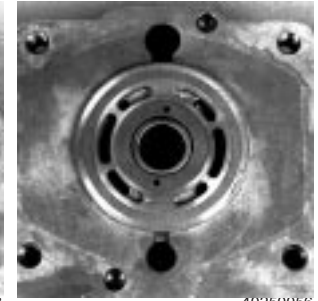

Fig. 61-29 - Install Valve Plate

Install the two (2) alignment pins, and install a new gasket onto the housing .

Install the end cap (with valve plate installed) onto the housing, aligning the marks made at disassembly.

When the end cap is properly installed, the cylinder block spring will hold the end cap away from the housing approximately 3 mm (1/8 in.).

Install the four (4) screws and washers that retain the housing to the end cap and torque evenly to 81 to 95 Nm (60 to 70 lbf•ft).



Fig. 61-30 - Pump Valve Plates

CAUTION

Be certain all parts are properly aligned. Do not force the end cap into position on the housing.

Rotate the shaft to assure correct assembly. When properly assembled, a maximum torque of 9.5 Nm (7 lbf•ft) should be required to turn the shaft.

Assemble the following components as described in the “Minor Repair” section:

- Auxiliary Mounting Pad Coupling and Cover
- Easy-Ride Valves
- Charge Relief Valve
- Charge Check / High Pressure Relief Valves



Fig. 61-31 - Install End Cap Gasket and End Cap



Fig. 61-32 - End Cap Installed



Notes

Major Repair - Tandem Pump

General

The following procedures are for the complete disassembly and reassembly (Major Repair) of the Series 40 - M25 Tandem Pump.

Cleanliness is a primary means of assuring satisfactory hydraulic pump life, on either new or repaired units. Cleaning parts by using a clean solvent wash and air drying is usually adequate. As with any precision equipment, all parts must be kept free of foreign materials and chemicals. Protect all exposed sealing surfaces and open cavities from damage and foreign material.

During the assembly of the Series 40 - M25 tandem pump, all surfaces which have relative motion between two parts should be coated with a film of clean hydraulic oil. This will assure that these surfaces will be lubricated during start-up.

It is recommended that all O-rings and gaskets be replaced. Lightly lubricate all O-rings with clean petroleum jelly prior to assembly. All gasket sealing surfaces must be cleaned prior to installing new gaskets.

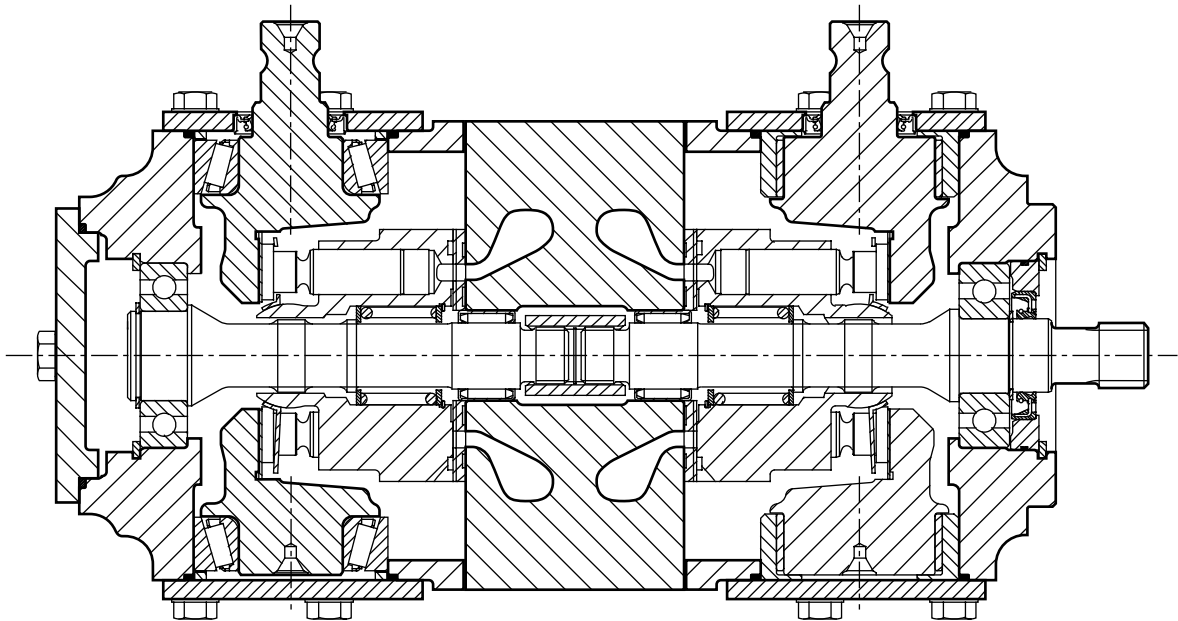

With Tapered Roller Trunnion Bearings

With Journal Trunnion Bearings

Fig. 62-1 - Cross Section View of Series 40 - M25 Variable Displacement Tandem Pump

40250076

Major Repair - Tandem Pump (Continued)

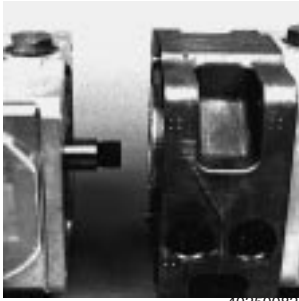

Fig. 62-2 - Separate Front Housing from Center Section

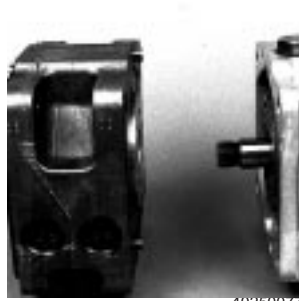

Fig. 62-3 - Separate Rear Housing from Center Section

Disassembly Procedures for Tandem Pump

Prior to performing Major Repairs on the Series 40 - M25 Tandem Pump, remove the external components as described in the "Minor Repair" section. These include the following:

- Auxiliary Mounting Pad Cover
- Charge Relief Valve
- Charge Check / High Pressure Relief Valves

After removal of these components, mark the location of the pump housings and center section, and remove the four (4) screws (using a 5/8" hex wrench) and washers which retain each pump housing to the center section.

Remove the housings from the center section and valve plates. Do not allow the valve plates to fall from the center section. Remove the gaskets and alignment pins from the center section.

Once the pump sections are removed from the center section, they may be disassembled using the procedures outlined in the "Major Repair - Variable Pump" section of this manual. The center section serves as the end cap for both pump sections.

NOTE: A drive shaft seal cover assembly is used only on the front pump section. The rear pump section shaft bearing is held in the housing with a retaining ring only.

Reconditioning and Replacement of Parts

The following procedures apply to the tandem pump center section:

Inspect the needle bearings and drive coupling in the center section. If replacement is necessary, remove the shaft needle bearings using a suitable puller. Do not damage the valve plate surface of the end cap. Remove the drive coupling located between the bearings.

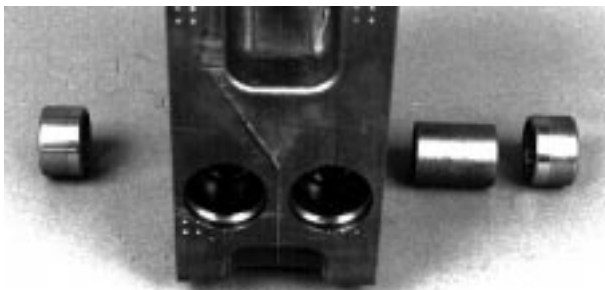

Fig. 62-4 - Shaft Needle Bearings and Drive Coupling Removed (Tandem Pump)

Major Repair - Tandem Pump (Continued)

Press a new needle bearing into the center section using a suitable press pin. When installed correctly, the bearing cage will protrude from 2.0 to 2.5 mm (0.08 to 0.10 in.) from the surface of the center section to serve as a pilot for the valve plate.

CAUTION

When installing the needle bearing, the printed (numbered) end of the bearing cage must face the press pin.



Fig. 62-5 - Needle Bearing Installed in Center Section (Tandem Pump)

Install the drive coupling into the center section. Install the second needle bearing into the center section, following the procedure outlined above.



Fig. 62-6 - Drive Coupling in place in Center Section for Installation of Second Needle Bearing (Tandem Pump)

Assembly Procedures for Tandem Pump

Clean and lightly oil parts prior to assembly of the pump. Be sure to torque all threaded parts to recommended torque levels.

CAUTION

Most parts have critical, high tolerance surfaces. Caution must be exercised to prevent damage to these surfaces during assembly. Protect exposed surfaces, openings, and ports from damage and foreign material.

Assemble the swashplate, swashplate bearings, drive shaft, and cylinder block of each pump section using the procedures outlined in the "Major Repair - Variable Displacement Pump" section of this manual.

Major Repair - Tandem Pump (Continued)

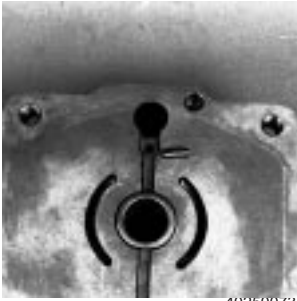

Fig. 62-7 - Install Valve Plate Pins

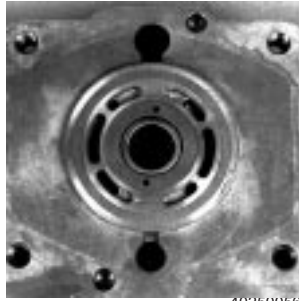

Fig. 62-8 - Install Valve Plate

Install the valve plate locating pins into the center section.

Coat the back (steel side) of the valve plates with petroleum jelly to hold them in position, and install the valve plates onto the center section, with the bronze face visible. The notch on the valve plate must engage the locating pin. Be certain the correct valve plate is installed on the center section for each pump section. Refer to the appropriate Service Parts Manual for more information.



C C W

C W

Fig. 62-9 - Pump Valve Plates

Since the tandem pump sections are mounted “back-to-back,” each section will have a different valve plate installed. A “clockwise” (CW) rotation unit will have a “clockwise” (CW) valve plate installed in the front section, and a “counterclockwise” (CCW) valve plate installed in the rear section. A “counterclockwise” (CCW) rotation unit will have a “counterclockwise” (CCW) valve plate installed in the front section, and a “clockwise” (CW) valve plate installed in the rear section.



Fig. 62-10 - Install Center Section Gasket



Fig. 62-11 - Assemble Rear Pump Section to Center Section

Install the four (4) alignment pins in the center section. Install a new rear pump housing gasket.

Assemble the rear pump section onto the center section (with valve plate installed). Align the drive coupling splines while assembling.

NOTE: The charge pressure supply port and system ports “C” and “D” on the center section are located next to the rear pump section.

When the sections are properly assembled, the cylinder block spring will hold the center section away from the housing approximately 3 mm (1/8 in.).

Install the four (4) screws and washers that retain the rear housing to the center section and torque evenly to 81 to 95 Nm (60 to 70 lbf•ft).

CAUTION

Be certain all parts are properly aligned Do not force the center section or housing into position.

Major Repair - Tandem Pump (Continued)

Install a new front pump housing gasket, and assemble the front pump section onto the assembled center and rear section. Align the drive coupling splines while assembling.

When the sections are properly assembled, the cylinder block spring will hold the center section away from the housing approximately 3 mm (1/8 in.).

Install the four (4) screws and washers that retain the front housing to the center section and torque evenly to 81 to 95 Nm (60 to 70 lbf•ft).

Rotate the shaft to assure correct assembly. When properly assembled, a maximum torque of 9.5 Nm (7 lbf•ft) should be required to turn the shaft.

Assemble the following components as described in the “Minor Repair” section:

- Auxiliary Mounting Pad Cover
- Charge Relief Valve
- Charge Check / High Pressure Relief Valves

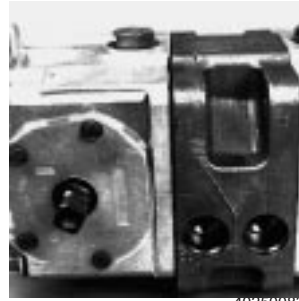

Fig. 62-12 - Front Pump Section Assembled to Center Section



Fig. 62-13 - Torque Housing Screws

Notes

Major Repair - Fixed Motor

General

The following procedures are for the complete disassembly and reassembly (Major Repair) of the Series 40 - M25 Fixed Motor.

Cleanliness is a primary means of assuring satisfactory hydraulic pump life, on either new or repaired units. Cleaning parts by using a clean solvent wash and air drying is usually adequate. As with any precision equipment, all parts must be kept free of foreign materials and chemicals. Protect all exposed sealing surfaces and open cavities from damage and foreign material.

During the assembly of the Series 40 - M25 fixed motor, all surfaces which have relative motion between two parts should be coated with a film of clean hydraulic oil. This will assure that these surfaces will be lubricated during start-up.

It is recommended that all O-rings and gaskets be replaced. Lightly lubricate all O-rings with clean petroleum jelly prior to assembly. All gasket sealing surfaces must be cleaned prior to installing new gaskets.

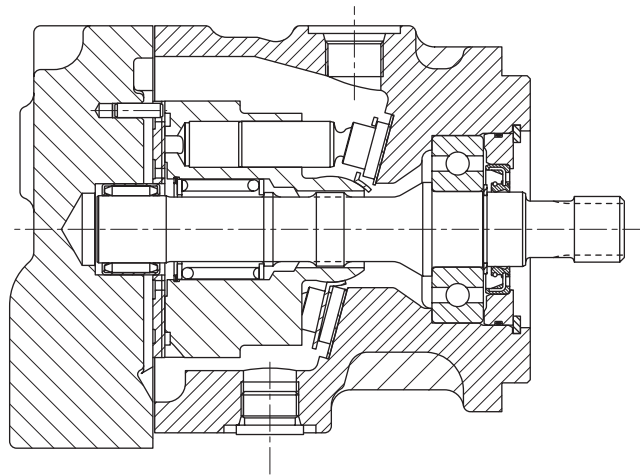

Cross Section View of Series 40 - M25 Fixed Displacement Motor

40250113

Major Repair - Fixed Motor (Continued)

Disassembly Procedures for Fixed Motor

Prior to performing Major Repairs, remove the external components as described in the Minor Repair section.

Place the motor on a work surface with the end cap up. Remove the four (4) screws (item B41) that retain the end cap (item E01) to the housing (item G01 or item G02).

Remove the end cap with the valve plate (item B52). Do not allow the valve plate to fall from the end cap. Remove the gasket (item B37) from the housing.

Carefully remove the valve plate from the end cap. It may be necessary to pry the valve plate off with a small screwdriver. Remove the alignment sleeves (item B40) from the end cap or housing.

CAUTION

Caution must be exercised to prevent damage to the valve plate and end cap surfaces.

Lay the motor on its side and remove the cylinder block assembly (item B22) from the housing.

Remove the slipper guide (item B36) and the piston assemblies (item B32) from the cylinder block.

Using an O-ring pick or wire, remove the thrust plate (item B21) from the housing.

Remove the retaining ring (item D08) and remove the output shaft seal carrier (item D07) with the seal (item B02). Remove the O-ring (item D06) from the carrier. Press the old seal out of the carrier. Refer to the Minor Repair section for further information.

Slide the output shaft and bearing assembly out of the housing.

Remove the retaining ring (item D05) and press the output shaft (item D01) out of the bearing (item D04).

Refer to Minor Repair section for seal removal information.

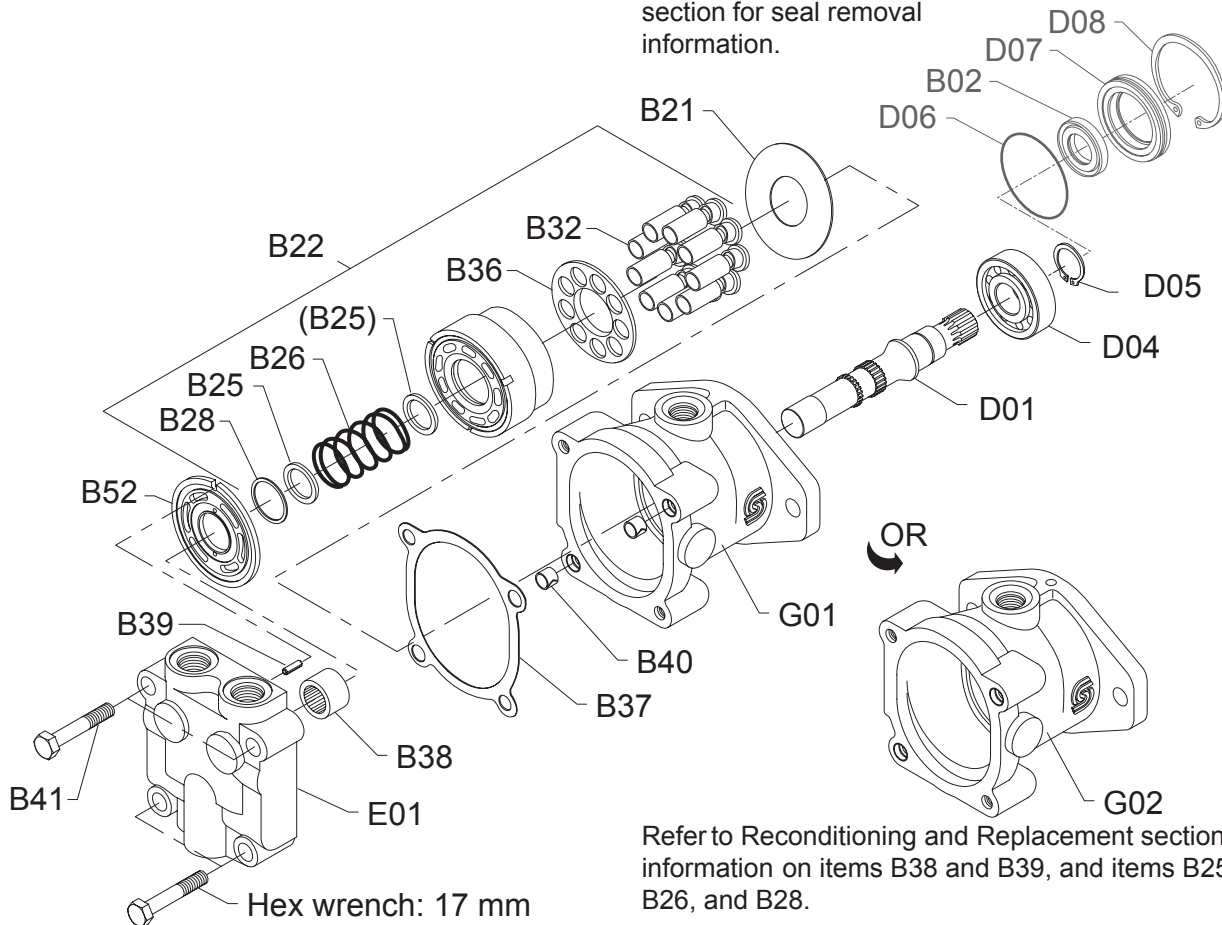

Refer to Reconditioning and Replacement section for information on items B38 and B39, and items B25, B26, and B28.

Major Repair - Fixed Motor (Continued)

Reconditioning and Replacement of Parts

Inspect all parts for damage, nicks, or unusual wear patterns. Replace all parts having unusual or excessive wear or discoloration.

Cracks are not allowed in any surface of the valve plate (item B52) or cylinder block. The running and sealing surfaces of the valve plate and cylinder block must be flat and free of nicks and burrs. Replace valve plates or cylinder blocks that show evidence of metal transfer, wear, or erosion on the running surface.

If scratches, which can be felt with a fingernail or pencil lead, are found on the bronze surface of the valve plate or the running surface of the cylinder block, polish or replace the parts.

Remove the valve plate locating spring pin (item B39) if necessary. Press a new valve plate pin into the end cap until it protrudes from the machined surface of the end cap as indicated.

Inspect the needle bearing (item B38) in the end cap (item E01). If replacement is necessary, remove the shaft needle bearing using a suitable puller. Do not damage the valve plate surface of the end cap.

Press a new needle bearing into the end cap using a suitable press pin. When installed correctly, the bearing cage will protrude from the machined surface of the end cap as indicated to serve as a pilot for the valve plate.

NOTE: When installing the needle bearing, the printed (numbered) end of the bearing cage should face the press pin.

Replace all piston assemblies if brass slippers are scored or excessively rounded at the edges.

Compress the cylinder block spring (item B26) and remove the spiral retaining ring (item B28), outer washer (item B25), spring, and inner washer. Reassemble in the reverse order.

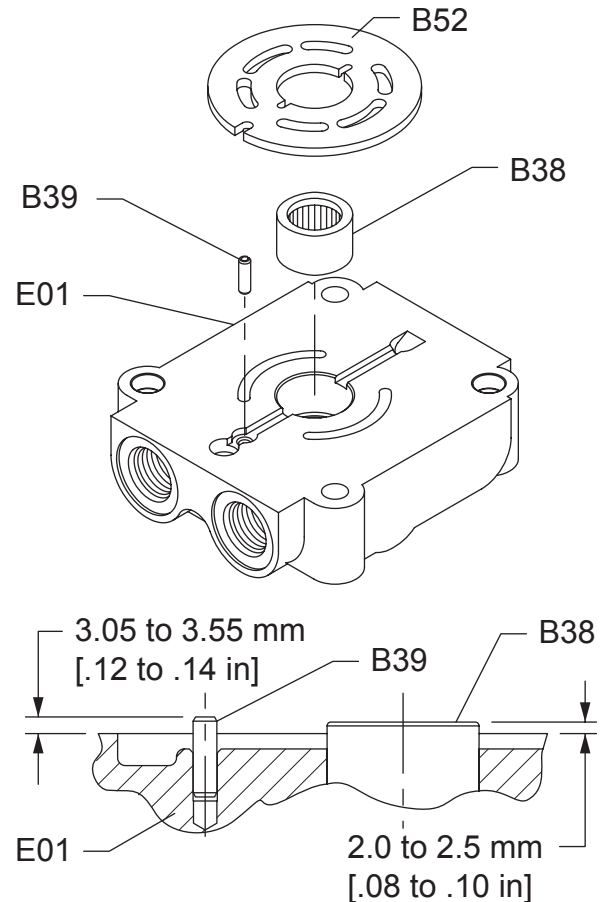

**INSTALLED HEIGHT
OF ITEMS B38 & B39**

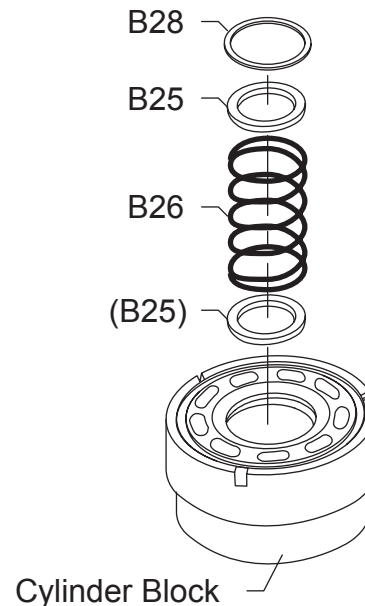

Major Repair - Fixed Motor (Continued)

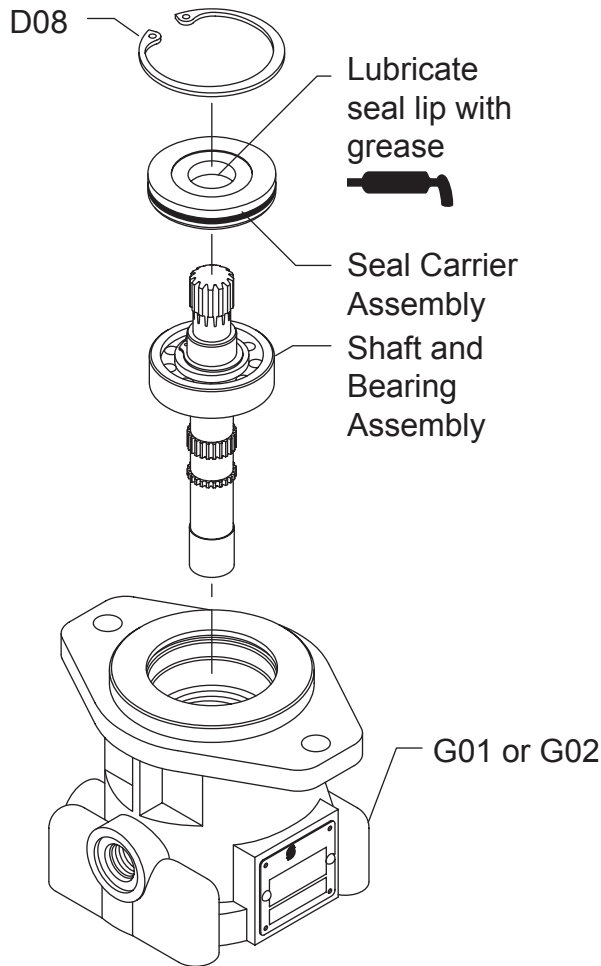

Assembly Procedures for Fixed Motor

Using caution to not damage the sealing surface, press the ball bearing (item D04) onto the output shaft (item D01). Install the bearing retaining ring (item D05) onto the shaft.

Install the output shaft and bearing into the housing (item G01 or item G02).

Install a new output shaft seal (item B02) into the seal carrier (item D07). Install a new O-ring (item D06) onto the seal carrier.

Install the seal carrier (with seal and O-ring) into the housing. **PROTECT SEAL LIP FROM DAMAGE!** Install the retaining ring (item D08). Refer to the Minor Repair section for further information.

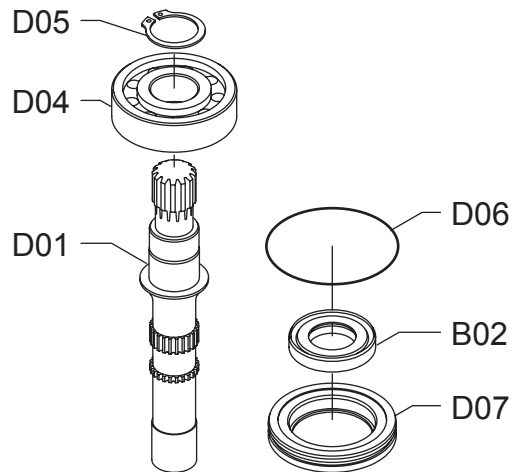

Assemble the piston assemblies (item B32) into the slipper retainer (item B36). Lubricate the pistons and cylinder block bores. Install the assembled retainer and pistons onto the cylinder block by inserting the piston assemblies into the cylinder block bores. The pistons and bores are not selectively fitted, therefore no specific piston and bore orientation is required.

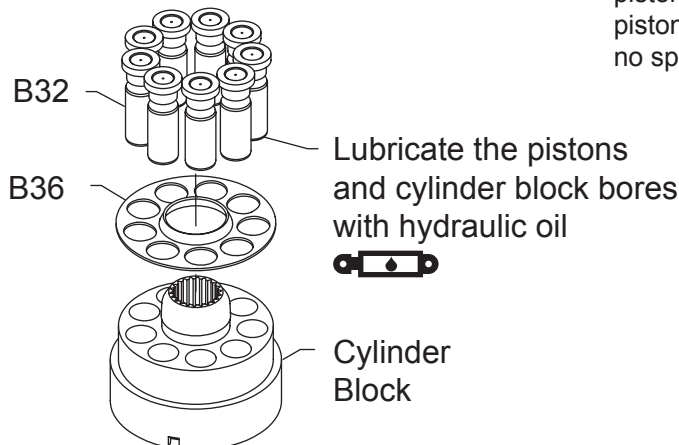

Major Repair - Fixed Motor (Continued)

The thrust plate (item B21) is reversible. Coat one (1) side of the thrust plate with grease or petroleum jelly to retain it in the motor housing, and install into the housing.

Lay the motor housing on its side and install the assembled cylinder block kit into the housing.

Coat the back (steel side) of the valve plate (item B52) with petroleum jelly or grease to hold it in position, and install the valve plate onto the end cap (item E01), with the bronze face visible. The notch on the valve plate must engage the locating pin (item B39). The motor valve plate is a bi-directional valve plate.

Install the two (2) alignment sleeves (item B40), and install a new gasket (item B37) onto the housing .

Install the end cap (with valve plate installed) onto the housing.

When the end cap is properly installed, the cylinder block spring will hold the end cap away from the housing approximately 3 mm (1/8 in.).

Install the four (4) screws (item B41) that retain the end cap to the housing and torque evenly.

CAUTION

Be certain all parts are properly aligned. Do not force the end cap into position on the housing.

Rotate the shaft to assure correct assembly. When properly assembled, a maximum torque of 9.5 Nm (7 lbf•ft) should be required to turn the shaft.

Assemble the external components as described in the Minor Repair section.

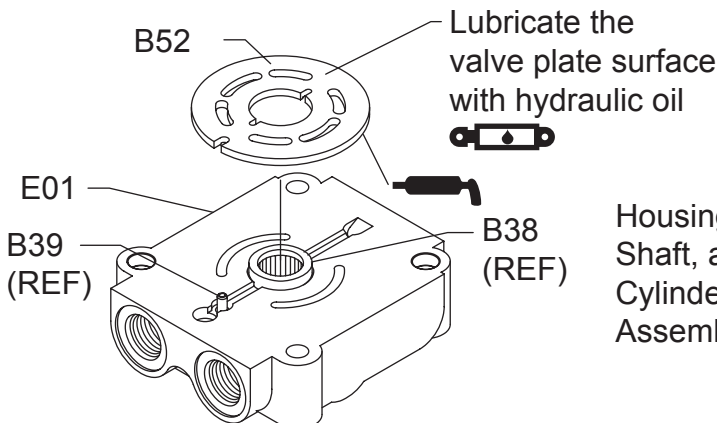
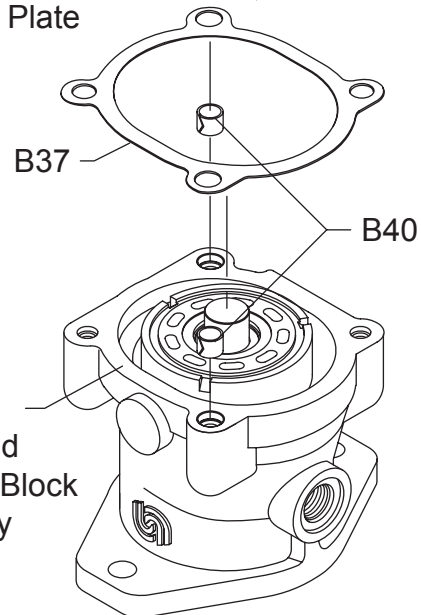
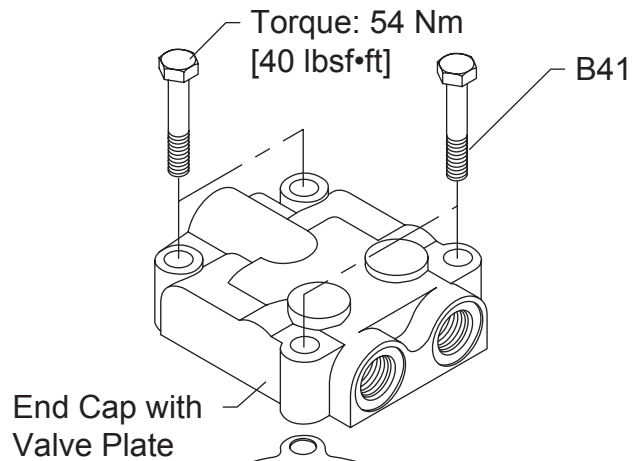
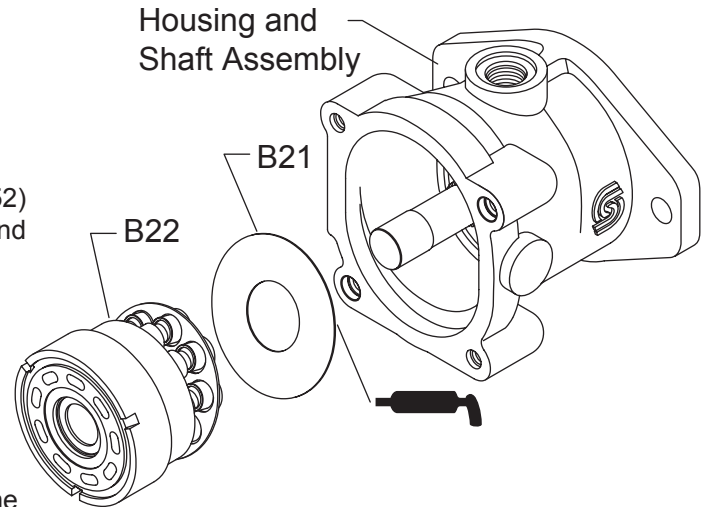



Notes

Major Repair - "U" Style Transmission

General

The procedures on the following pages are for the complete disassembly and reassembly (Major Repair) of the Series 40 - M25 "U" Style Transmission.

Cleanliness is a primary means of assuring satisfactory transmission life, on either new or repaired units. Cleaning parts by using a clean solvent wash and air drying is usually adequate. As with any precision equipment, all parts must be kept free of foreign materials and chemicals. Protect all exposed sealing surfaces and open cavities from damage and foreign material.

During the assembly of the Series 40 - M25U transmission, all surfaces which have relative motion between two parts should be coated with a film of clean hydraulic oil. This will assure that these surfaces will be lubricated during start-up.

It is recommended that all gaskets and O-rings be replaced. Lightly lubricate all O-rings with clean petroleum jelly prior to assembly. All gasket sealing surfaces must be cleaned prior to installing new gaskets.

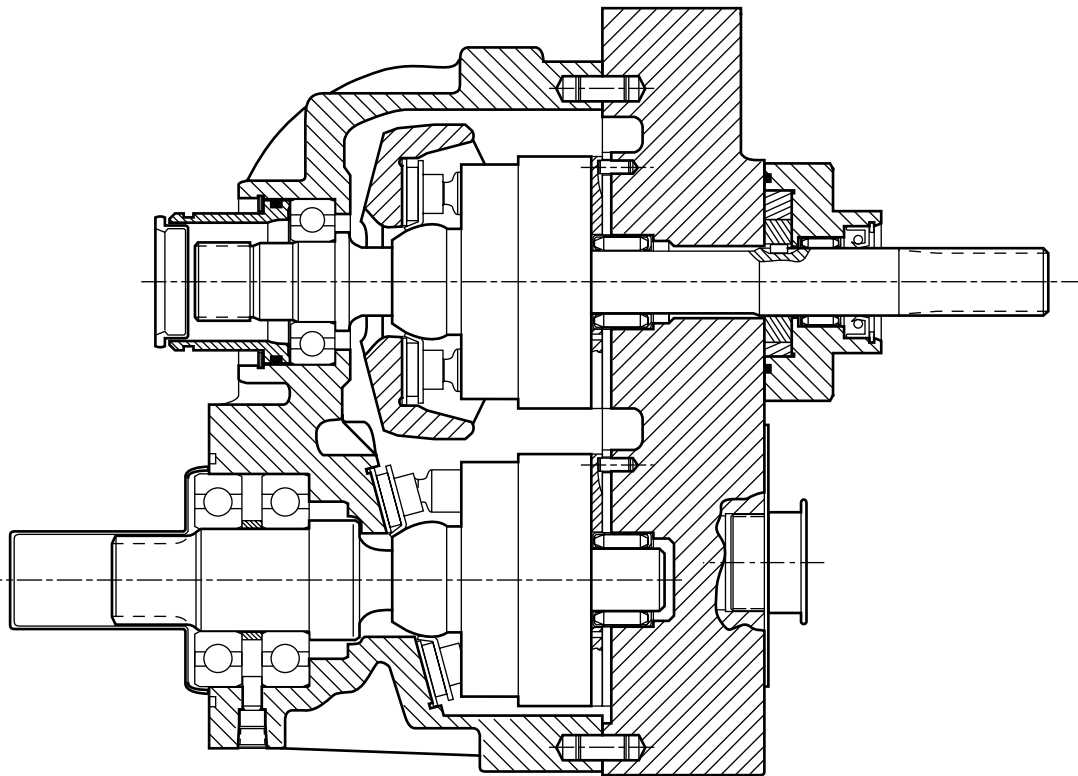

Fig. 65-1 - Cross Section View of Series 40 - M25 "U" Style Transmission

40250085

Major Repair - "U" Style Transmission (Continued)

Disassembly Procedures for "U" Style Transmission

Prior to performing Major Repairs on the Series 40 - M25U transmission, remove the external components as described in the "Minor Repair" section of this manual. These include the following:

- Charge Check / High Pressure Relief Valves
- Charge Relief Valve
- Heat Exchanger Bypass Valve
- Filter Bypass Valve
- Filter Bypass Reverse Flow Check Valve
- Charge Pump

Remove the six (6) screws (using a 5/8" hex wrench and a 3/8" internal hex wrench) which retain the center section to the housing. Note the positions of the longer and shorter screws.

The cylinder block springs will separate the center section from the housing. Remove the center section from the housing.

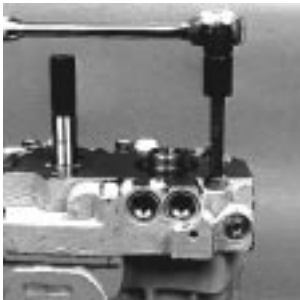

Fig. 65-2 - Remove Center Section Screws



Fig. 65-2 - Remove Center Section and Valve Plates

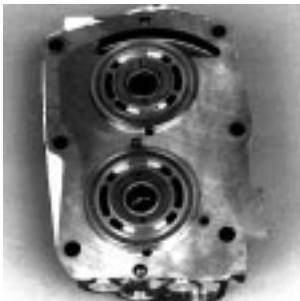

Fig. 65-4 - Remove Valve Plates from Center Section



Fig. 65-5 - Remove Valve Plate Pins

CAUTION

The pump and motor cylinder blocks may stick to the valve plates and center section. Exercise caution to prevent damage to the sealing surfaces.

Remove the gasket and two (2) alignment pins from the housing.

Carefully remove the valve plates from the center section. It may be necessary to pry the valve plates off with a small screwdriver. Remove the valve plate pins from the center section.

CAUTION

Caution must be exercised to prevent damage to the valve plate and center section surfaces.

Lay the transmission on its side and remove the motor cylinder block kit from the housing. Remove the pump cylinder block kit from the pump shaft.

Remove the slipper guide and the piston assemblies from the cylinder block kits.

NOTE: The pump and motor cylinder block kits are identical. In order to avoid mixing wear patterns, do not mix parts between the pump and motor kits.



Fig. 65-6 - Remove Cylinder Blocks from Housing



Fig. 65-7 - Cylinder Block Kit Components

Major Repair - "U" Style Transmission (Continued)

Using an O-ring pick or wire, remove the thrust plates from the swashplate and housing.

Using a 3/16" internal hex wrench, remove the pipe plug over the motor shaft bearing retaining pin.



Fig. 65-8 - Remove Thrust Plates



Fig. 65-9 - Remove Pipe Plug

Using a 4-40 (#4, 40 threads per inch) or 8-32 (#8, 32 threads per inch) machine screw, remove the motor shaft bearing retaining pin from the housing.

Remove the motor shaft assembly.



Fig. 65-10 - Remove Bearing Retaining Pin



Fig. 65-11 - Remove Motor Shaft Assembly

Press the motor shaft out of the bearings and spacer.



Fig. 65-12 - Components of Motor Shaft Assembly

Remove the spiral retaining ring and remove the PTO seal guide (with O-ring) from the housing.

Slide the pump shaft and bearing assembly from the housing. Press the shaft out of the bearing.

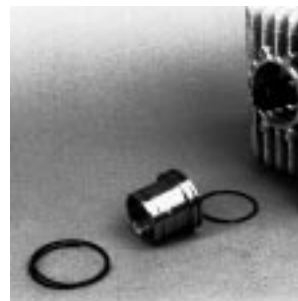

Fig. 65-13 - Remove PTO Seal Guide



Fig. 65-14 - Remove Pump Shaft and Bearing

Major Repair - "U" Style Transmission (Continued)



Fig. 65-15 - Remove Trunnion Covers

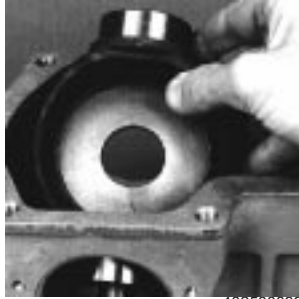

Fig. 65-16 - Remove Swashplate

With a 3/8" hex wrench, remove the tapping screws retaining the trunnion seal cover and trunnion cover to the housing. Mark the position of the covers for reassembly.

The trunnion seal cover assembly includes an O-ring, lip seal, and trunnion bearing on the control side. The trunnion cover assembly includes an O-ring and trunnion bearing on the side opposite the control. Remove these parts from the housing.

Tilt and remove the swashplate from the housing.

Reconditioning and Replacement of Parts

After disassembly all parts should be thoroughly cleaned in a suitable solvent. Replace all O-rings, gaskets, and seals.

Inspect all parts for damage, nicks, or unusual wear patterns. Replace all parts having unusual or excessive wear or discoloration.

Cracks are not allowed in any surface of the valve plates or cylinder blocks. The running and sealing surfaces of the valve plates and cylinder blocks must be flat and free of nicks and burrs. Replace valve plates or cylinder blocks that show evidence of metal transfer, wear, or erosion on the running surface.

If scratches, which can be felt with a fingernail or pencil lead, are found on the bronze surface of the valve plates or the running surface of the cylinder blocks, polish or replace the parts.

Inspect the needle bearings in the center section. If replacement is necessary, remove the shaft needle bearings using a suitable puller. Do not damage the Press new needle bearings into the center section using a suitable press pin. When installed correctly, the bearing cage will protrude from 2.3 to 2.8 mm (0.09 to 0.11 in.) from the surface of the center section to serve as pilots for the valve plates.

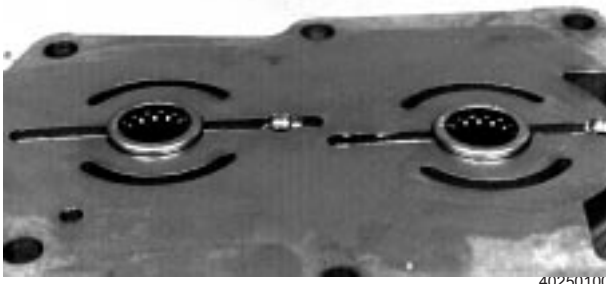

Fig. 65-17 - Bearings Installed in Center Section

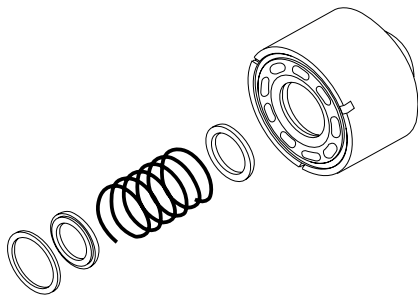

Fig. 65-18 - Cylinder Block Spring Components

CAUTION

When installing the needle bearing, the printed (numbered) end of the bearing cage must face the press pin.

Replace all piston assemblies if brass slippers are scored or excessively rounded at the edges

Compress the cylinder block spring and remove the spiral retaining ring, outer washer, spring, and inner washer. Reassemble in the reverse order.

Major Repair - "U" Style Transmission (Continued)

Assembly Procedures for "U" Style Transmission

Clean and lightly oil parts prior to assembly of the motor. Be sure to torque all threaded parts to recommended torque levels.

CAUTION

Most parts have critical, high tolerance surfaces. Caution must be exercised to prevent damage to these surfaces during assembly. Protect exposed surfaces, openings, and ports from damage and foreign material.

Install the washplate into the housing. Make sure the washplate control shaft is located on the desired side of the housing (note the marks made during disassembly).



40250099

Fig. 65-19 - Install Washplate

Install the trunnion cover (with O-ring and trunnion bearing) into the housing and over the washplate trunnion.

NOTE: The trunnion bearings are pressed into the cover assemblies so the split in each bearing will be located closest to the center section.

Using an arbor press, press a new seal into the trunnion seal cover. The outer face of the seal should be pressed flush with the outer surface of the seal cover. Be careful not to damage the seal.

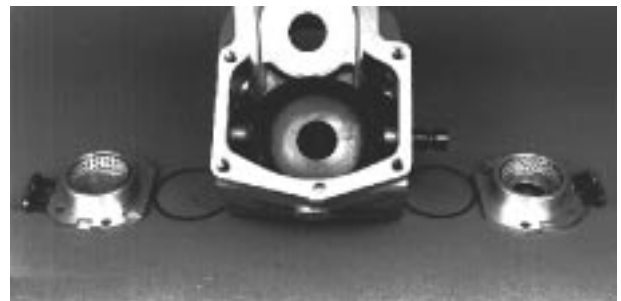

40250101

Fig. 65-20 - Trunnion Cover Components

Install the trunnion seal cover (with O-ring, seal, and trunnion bearing) into the housing and over the washplate trunnion, as described in the "Minor Repair" section of the Service Manual. Wrap the end of the washplate control shaft with thin plastic to prevent damage to the seal lip during installation.

Install the hex head tapping screws and torque to 8 to 12 Nm (6 to 9 lbs•ft).



40250102

Fig. 65-21 - Install Trunnion Seal Cover

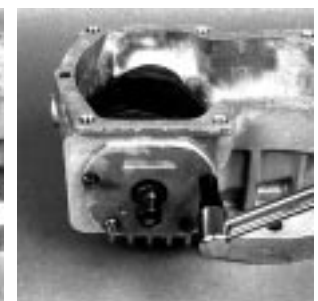

40250103

Fig. 65-22 - Torque Trunnion Cover Screws

Major Repair - "U" Style Transmission (Continued)

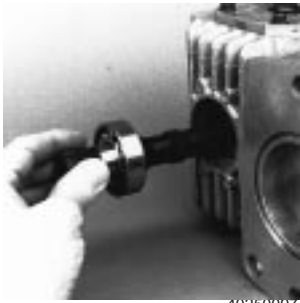

Fig. 65-23 - Install Pump Shaft and Bearing

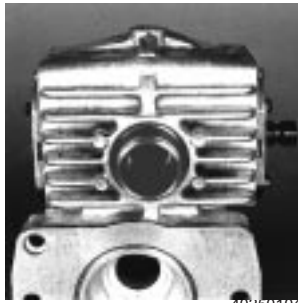

Fig. 65-24 - PTO Seal Guide Installed

Press the ball bearing onto the pump shaft. Install the pump shaft and bearing assembly into the housing.

Install the PTO seal guide and O-ring into the housing. Install the spiral retaining ring.



Fig. 65-25 - Motor Shaft Assembly

Press the inner bearing, spacer, and outer bearing onto the motor shaft



Fig. 65-26 - Install Motor Shaft Assembly



Fig. 65-27 - Install Bearing Retaining Pin

Install the motor shaft assembly into the housing.

Install the motor shaft bearing retaining pin into the housing.



Fig. 65-28 - Install Pipe Plug



Fig. 65-29 - Install Thrust Plates

Install the pipe plug over the motor shaft bearing retaining pin, and torque to 11 to 13 Nm (6 to 10 lbf•ft).

Coat the thrust plates with petroleum jelly and install into the housing and swashplate. The thrust plates are reversible.

Major Repair - “U” Style Transmission (Continued)

Assemble each cylinder block kit by installing the piston assemblies into the slipper guide. Lubricate the pistons and cylinder block bores. Install the assembled guide and pistons into the cylinder block by inserting the piston assemblies into the cylinder block bores. The pistons and bores are not selectively fitted, therefore no specific piston and bore orientation is required.

Lay the transmission housing on its side and install the cylinder block kits into the housing.

Place the transmission housing on a work surface with the center section opening up.

Install the valve plate locating pins into the center section.

Coat the back (steel side) of the valve plates with petroleum jelly to hold them in position and install the valve plates onto the center section, with their bronze faces visible. The notch on each valve plate must engage its locating pin.

A transmission set up for “clockwise” (CW) pump rotation will have a “clockwise” (CW) pump valve plate installed. A “counterclockwise” (CCW) rotation unit will have a “counterclockwise” (CCW) pump valve plate installed. Be certain the proper valve plate is used for the transmission input rotation. Refer to the appropriate Service Parts Manual for more information.

NOTE: Since the pump cylinder block kit is located to the rear of the center section, the appearance of the valve plate will be similar to that of the valve plate for the rear section of a tandem pump of the same rotation.

The motor valve plate is a bi-directional valve plate.



Fig. 65-30 - Install Piston Assemblies into Cylinder Block



Fig. 65-31 - Install Cylinder Block Kits



Fig. 65-32 - Install Valve Plate Pins

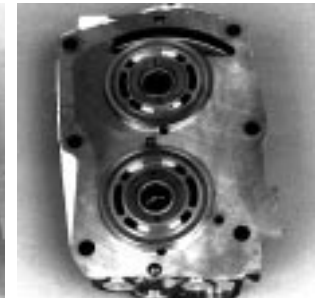

Fig. 65-33 - Install Pump and Motor Valve Plates

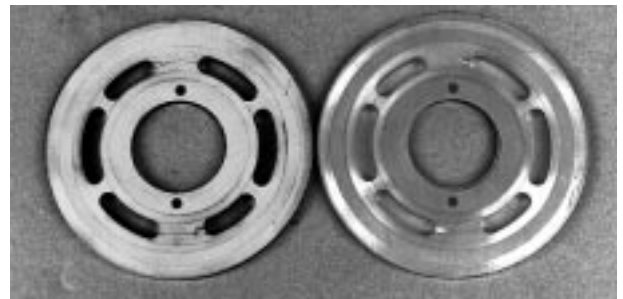

Fig. 65-34 - Pump Valve Plates



Fig. 65-35 - Motor Valve Plate

Major Repair - “U” Style Transmission (Continued)

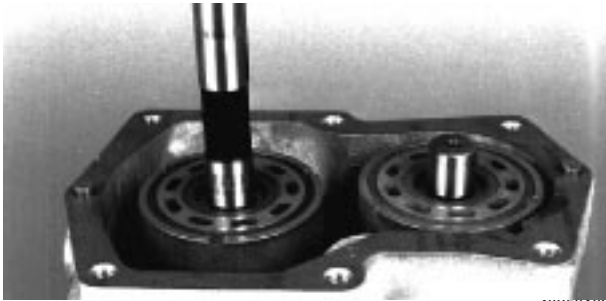

Fig. 65-36 - Install Alignment Pins and Center Section Gasket

Install the two (2) alignment pins, and install a new center section gasket onto the housing.

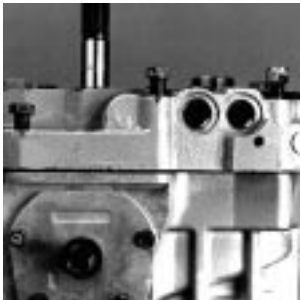

Fig. 65-37 - Center Section Installed



Fig. 65-38 - Torque Center Section Screws

Install the center section with valve plates onto the transmission housing.

CAUTION

Be certain all parts are properly aligned Do not force the center section into position on the housing.

When the center section is properly installed, the cylinder block springs will hold the end center section away from the housing approximately 3 mm (1/8 in.).

Install the six (6) screws that retain the center section to the housing and torque evenly to 45 to 55 Nm (33 to 41 lbsf•ft).

Rotate the pump and motor shafts to assure correct assembly. When properly assembled, a maximum torque of 4.7 Nm (3.5 lbsf•ft) should be required to turn either shaft.

Assemble the following components as described in the “Minor Repair” section of this manual:

- Charge Check / High Pressure Relief Valves
- Charge Relief Valve
- Heat Exchanger Bypass Valve
- Filter Bypass Valve
- Filter Bypass Reverse Flow Check Valve
- Charge Pump







Hydraulic Power Systems

SAUER-SUNDSTRAND Hydraulic Power Systems - Market Leaders Worldwide

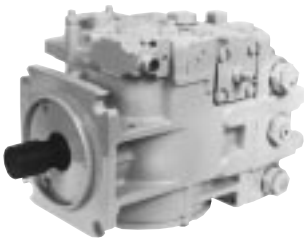
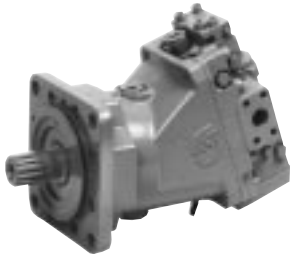
SAUER-SUNDSTRAND is a world leader in the design and manufacture of Hydraulic Power Systems. Research and development resources in both North America and Europe enable SAUER-SUNDSTRAND to offer a wide range of design solutions utilizing hydraulic power system technology.

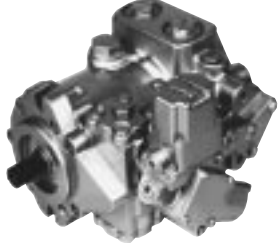
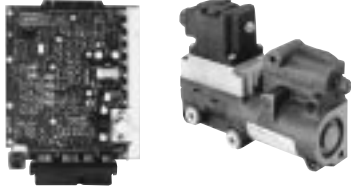
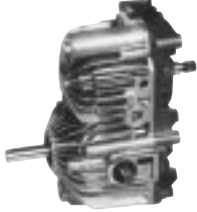
SAUER-SUNDSTRAND specializes in integrating a full range of system components to provide vehicle designers with the most advanced total-design system.

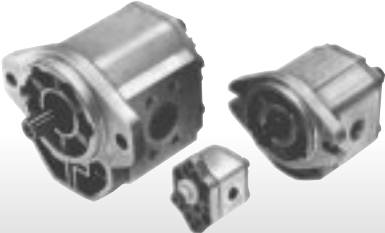
SAUER-SUNDSTRAND is Your World Source for Controlled Hydraulic Power Systems.

 <p>Heavy Duty Axial Piston Pumps and Motors</p>	 <p>Heavy Duty Bent Axis Variable Motors</p>	 <p>Cartridge Motors/ Compact Wheel Drives</p>
 <p>Medium Duty Axial Piston Pumps and Motors</p>	 <p>Microcontrollers and Electrohydraulic Controls</p>	 <p>Hydrostatic Transmission Packages</p>
 <p>Open Circuit Axial Piston Pumps</p>	 <p>Gear Pumps and Motors</p>	 <p>Genuine Service Parts</p>

Worldwide Service Support

SAUER-SUNDSTRAND provides comprehensive worldwide service for its products through an extensive network of Authorized Service Centers strategically located in all parts of the world.

Look to SAUER-SUNDSTRAND for the best in WORLDWIDE SERVICE.

