

Introduction

The purpose of this manual is to provide information useful in the normal servicing of the Series 40 - M35 Hydrostatic Pumps and Motors. This manual includes unit and component description, troubleshooting, adjustment, and minor repair procedures. Following the procedures in this manual, the minor repairs may be performed without affecting the unit warranty.

A Series 40 Transmission does occasionally require servicing, and these units have been designed with this in mind. Some repairs and adjustments can be accomplished without removing the unit from its installed location, provided that the unit is accessible and can be thoroughly cleaned before beginning any procedures. Since dirt or contamination is the greatest enemy of any hydraulic equipment, the greatest possible cleanliness is necessary.

Sundstrand-Sauer provides a complete repair service for its products. Contact any Sundstrand-Sauer Authorized Service Center for details. (See pages 35 and 36.

The torque values, pressures, and dimensions used throughout this manual are given in English and metric measurements.



Variable Displacement Pump



Variable Displacement Tandem Pump



Fixed Displacement Motor



Variable Displacement Motor

General Description

The Series 40 - M35 pumps and motors can be applied separately or combined in a system to transfer and control power. When combined in such a system, these units provide an infinitely variable speed range between zero and maximum, in both forward and reverse modes of operation.

Series 40 - M35 variable displacement pumps are a compact, state-of-the-art design, using the parallel axial piston / slipper design in conjunction with a tiltable swashplate to vary the pump's displacement. Reversing the direction of tilt of the swashplate reverses the flow of oil from the pump and thus reverses the direction of the motor output rotation.

A direct displacement control system is used on the Series 40 - M35 variable displacement pump and tandem pump. The swashplate control shaft is connected directly to the swashplate. Movement of the control shaft causes a proportional swashplate movement and change in pump flow. This control can be located on either side of the unit.

A charge relief valve and charge check valves are included in the pump end cap to control the makeup and cooling oil flow for the system. The charge check valves also incorporate the bypass valve function and high pressure relief valve function into their design.

The Series 40 - M35 variable displacement pump is available with a 0.72 in³/rev (11.8 cc/rev) integral gerotor type charge pump. The Series 40 - M35 tandem pump is available with a 1.00 in³/rev (16.4 cc/rev) integral gerotor type charge pump.

The fixed and variable displacement motors also incorporate the parallel axial piston / slipper design. Fixed displacement motors utilize a fixed swashplate angle. The variable displacement motors use a variable angle swashplate with a direct displacement control system, similar to the variable displacement pumps.

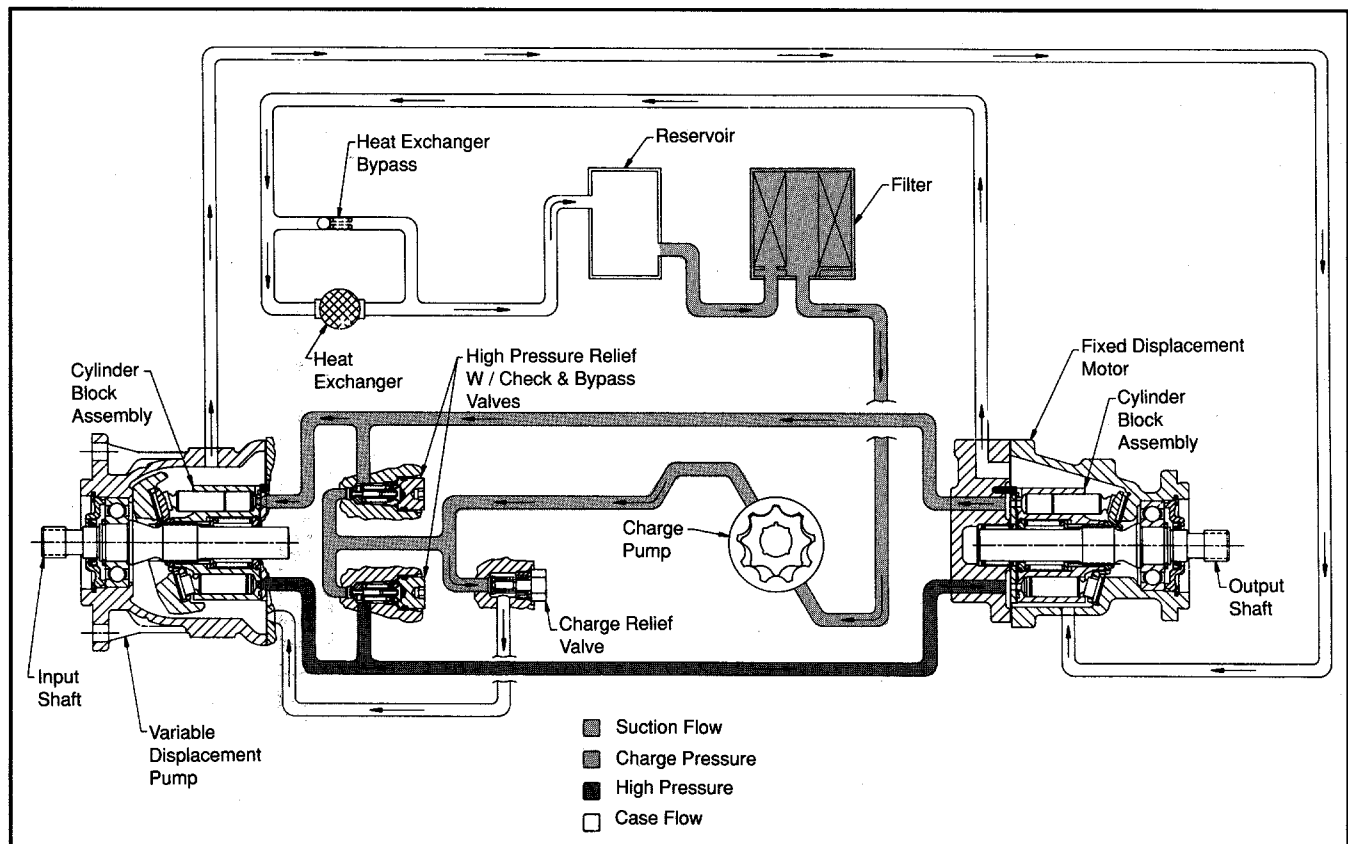

Fig. 1 - Typical Series 40 - M35 Variable Pump -- Fixed Motor Transmission Schematic

Transmission Hydraulic Support System

The Series 40 - M35 Pumps and Motors are easy to install, requiring no adjustments and few auxiliary components. They have their own hydraulic support system which is discussed in this section.

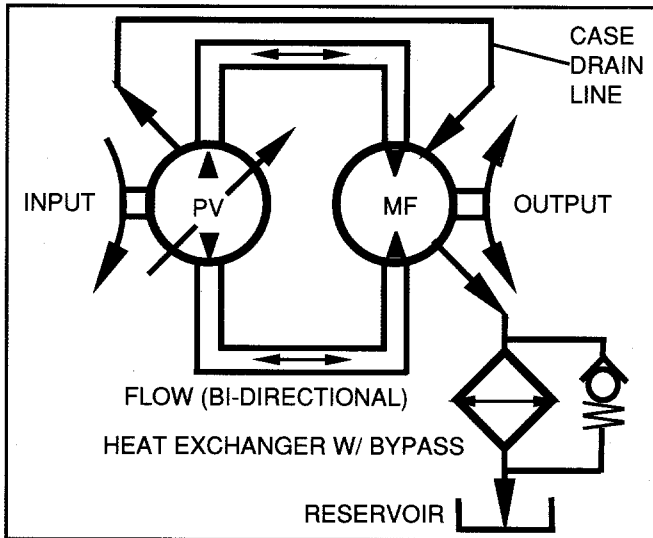

Fig. 2 - Basic Closed Circuit

Basic Closed Circuit

The main ports of the pump are connected by hydraulic lines to the main ports of the motor. Fluid flows, in either direction, from the pump to the motor then back to the pump in this closed circuit. Either of the hydraulic lines can be under high pressure. The direction and speed of fluid flow (and the motor output shaft rotation) depends on the position of the pump swash-plate. The system pressure is determined by the machine load.

Case Drain and Heat Exchanger

The pump and motor require case drain lines to remove hot fluid from the system. The pump case should be drained from its upper drain port to insure the case remains full of fluid. The pump case drain is then connected to the lower drain port on the motor housing. The upper motor housing drain port is then connected to the reservoir.

A heat exchanger, with a bypass valve, may be required to cool the case drain fluid before it returns to the reservoir.

CAUTION

Continuous case pressure should not exceed 25 PSI (1.7 BAR).

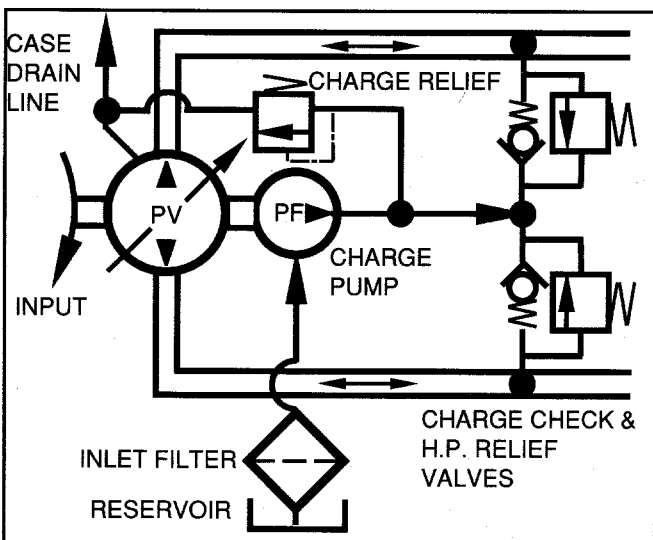

Fig. 3 - Charge System

Charge System and Inlet Filter

The charge pump supplies cool fluid to the system and keeps the closed loop charged to prevent cavitation. The charge pump draws its fluid from the system reservoir. An inlet filter is required to insure that only clean fluid enters the system.

CAUTION

The inlet vacuum, measured at the charge pump inlet should not exceed 5 in. Hg (.8 BAR abs.), except during cold starts.

Since either of the main hydraulic lines can be high pressure, two (2) charge check valves are used to direct the charge supply into the low pressure line. These check valves (located in the pump end cap) also incorporate the optional high pressure relief valve function. Any charge flow not being used for the closed circuit is discharged over a direct operating charge relief valve, through the pump and motor housings, and back to the system reservoir. The charge pressure relief valve is factory set for 100 Δ PSI (7 BAR) above case pressure under test conditions. Exact charge pressure may vary in various applications.

NOTE: Certain M35 pumps have a charge pressure relief valve setting of 200 Δ PSI (14 BAR)

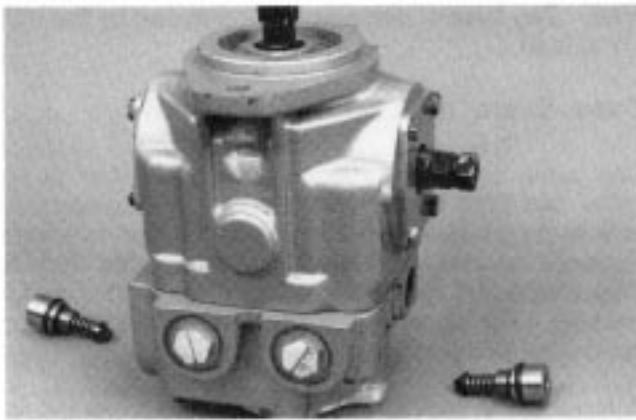

Fig. 4 - Charge Check and High Pressure Relief Valves

High Pressure Relief Valves

Two (2) optional combination check / high pressure relief valves may be provided in the pump end cap for overload protection. These cartridge type relief valves are factory set, and are not field adjustable. Changing the maximum system pressure can be accomplished by installing different cartridges with the desired setting.

Safety Precautions

- The loss of hydrostatic drive line power in an acceleration, deceleration, or neutral mode may cause a loss of hydrostatic braking capacity. A braking system, redundant to the hydrostatic transmission must, therefore, be provided which is adequate to stop and/or hold the system should the condition develop.

- Certain service procedures may require the vehicle/machine to be disabled (wheels raised off the ground, work function disconnected, etc.) while performing them in order to prevent injury to the technician and bystanders.

- Use caution when dealing with hydraulic fluid under pressure. Escaping hydraulic fluid under pressure can have sufficient force to penetrate your skin causing serious injury. This fluid may also be hot enough to burn. Serious infection or reactions can develop if proper medical treatment is not administered immediately.

- Some cleaning solvents are flammable. To avoid possible fire, do not use cleaning solvents in an area where a source of ignition may be present.

Technical Data - Variable Displacement Pump / Tandem Pump

Product Type		M35 Variable Pump	M35 Tandem Pump
Displacement			
In ³ /Rev		2.1	2.1 (each section)
cc/Rev		35	35 (each section)
Input Speed			
Max - RPM (Full Angle)		4500	ALL UNITS →
Continuous - RPM (Full Angle)		3600	
Input Mounting Flange (per SAE J744)			
		SAE B	SAE B
Input Shaft (Std. Spline)			
Number of Teeth		15	ALL UNITS →
Pitch		16/32	
Weight			
LBS		55	99
KG		25	45
Pressure			
Maximum	PSI	5000	ALL UNITS →
	BAR	345	
Continuous	PSI	3000	ALL UNITS →
	BAR	210	
Case Pressure			
Continuous	PSI	25	ALL UNITS →
	BAR	1.7	
Maximum (Cold Start)	PSI	75	ALL UNITS →
	BAR	5.2	
Temperature at Hottest Point in Transmission (normally at case drain)			
Maximum	°F	220	ALL UNITS →
	°C	104	
Continuous	°F	180	ALL UNITS →
	°C	82	
Fluid Viscosity Limits -- SUS (CST)			
Optimum		70 (13)	
Min. Continuous		55 (9.0)	
Min. Intermittent		47 (6.4)	ALL UNITS →
Max. Continuous		500 (110)	
Max. Cold Start		7500 (1600)	
Suggested Filtration			
Dedicated Reservoir		Beta 10 = 1.5 to 2.0	ALL UNITS →
Common Reservoir		Beta 10 = 10 to 20	
Charge Inlet Vacuum at Sea Level			
Normal	in. Hg	5	
	BAR (abs.)	.8	ALL UNITS →
Cold Start	in. Hg	10	
	BAR (abs.)	.7	

Technical Data - Fixed Displacement Motor / Variable Displacement Motor

Product Type		M35 Fixed Motor	M35 Variable Motor
Displacement			
In ³ /Rev		2.1	2.1 (Maximum)
cc/Rev		35	35 (Maximum)
Output Speed			
Full Angle (17°)	Max - RPM	4500	4500
	Continuous - RPM	3600	3600
Low Angle (< 11°)	Max - RPM	---	5300
	Continuous - RPM	---	4100
Output Mounting Flange (per SAE J744)			
		SAE B	SAE B
Output Shaft (Std. Spline)			
Number of Teeth		15	ALL UNITS →
Pitch		16/32	
Weight			
LBS		26	47
KG		11.5	21
Pressure			
Maximum	PSI	5000	ALL UNITS →
	BAR	345	
Continuous	PSI	3000	ALL UNITS →
	BAR	210	
Case Pressure			
Continuous	PSI	25	ALL UNITS →
	BAR	1.7	
Maximum (Cold Start)	PSI	75	ALL UNITS →
	BAR	5.2	
Temperature at Hottest Point in Transmission (normally at case drain)			
Maximum	°F	220	ALL UNITS →
	°C	104	
Continuous	°F	180	ALL UNITS →
	°C	82	
Fluid Viscosity Limits -- SUS (CST)			
Optimum		70 (13)	
Min. Continuous		55 (9.0)	
Min. Intermittent		47 (6.4)	ALL UNITS →
Max. Continuous		500 (110)	
Max. Cold Start		7500 (1600)	
Suggested Filtration			
Dedicated Reservoir		Beta 10 = 1.5 to 2.0	ALL UNITS →
Common Reservoir		Beta 10 = 10 to 20	

Controls and Options

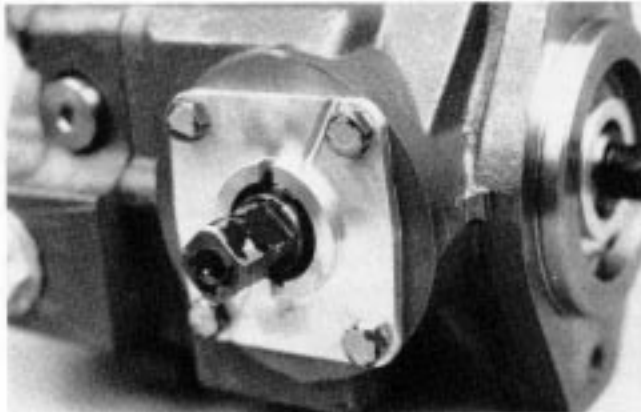

Fig. 5 - Variable Displacement Pump with Direct Displacement Control

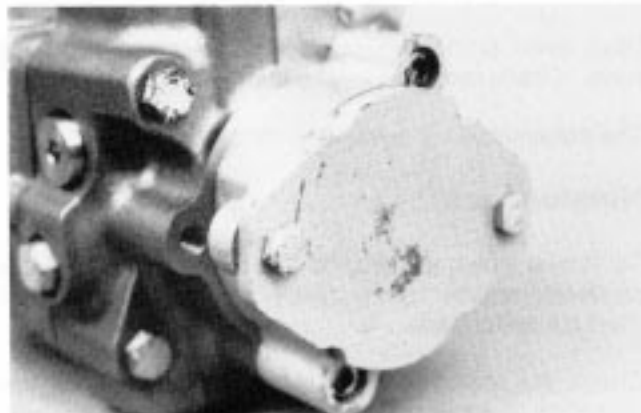

Fig. 6 - Variable Displacement Pump with Auxiliary Mounting Pad

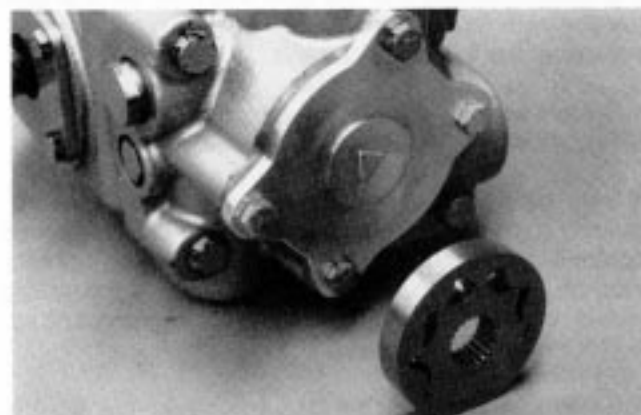

Fig. 7 - Variable Displacement Pump with Charge Pump

Direct Displacement Control

The direct displacement control (DDC) may be located on either side of the unit, and provides a simple method of control. Movement of the swashplate control shaft produces a proportional swashplate movement and change in pump flow and/or motor shaft speed / direction.

The vehicle/machine control system should be designed to return the swashplate to its neutral position. The DDC is available on variable pumps, tandem pumps, and variable motors.

Auxiliary Mounting Pads

SAE "A" and "B" auxiliary mounting pads are available on Series 40 - M35 variable pumps and tandem pumps. This pad is used for mounting an auxiliary hydraulic pump or separate charge pump.

Charge Pumps

A fixed displacement, gerotor type charge pump may be provided as a part of the variable pump and tandem pump. Pumps without an integral charge pump require that a separate, fixed displacement pump be provided as part of the system.

Bypass Valve

In some applications it is desirable to bypass fluid around the variable displacement pump allowing, for example, a vehicle to be moved short distances at low speeds without running the prime mover. This is accomplished by manually operated bypass valves incorporated into the charge check / high pressure relief valves in the pump. When open (unscrewed 4 turns maximum), these valves connect both sides of the pump/motor closed circuit, allowing the motor to turn. Both valves must be opened for bypass operation, and must be fully closed for normal operation. The system prime mover should be shut down when opening or closing the bypass valves.

NOTE: Opening the bypass valves more than 4 turns may result in external leakage.

WARNING

Opening the bypass valves will result in a loss of hydrostatic braking capacity. Take precautions to prevent machine movement when opening the valves.

Start-Up & Maintenance

Fluids

Hydraulic fluids used with Sundstrand-Sauer products should be carefully selected with assistance from a reputable supplier, following the guidelines presented in the "Fluid Quality Requirements" bulletin, BLN-9887.

Start-Up Procedure

The following start-up procedure should always be followed when starting-up a new installation or when restarting an installation in which either the pump or motor had been removed from the system.

WARNING

The following procedure may require the vehicle/machine to be disabled (wheels raised off the ground, work function disconnected, etc.) while performing the procedure in order to prevent injury to the technician and bystanders.

Prior to installing the pump and/or motor, inspect the units for damage incurred during shipping and handling. Make certain all system components (reservoir, hoses, valves, fittings, heat exchanger, etc.) are clean prior to filling with fluid.

Fill the reservoir with recommended hydraulic fluid which should be passed through a 10 micron (nominal, no bypass) filter prior to entering the reservoir.

The inlet line leading from the reservoir to the pump must be filled prior to start up. Check inlet line for properly tightened fittings and make sure it is free of restrictions and air leaks.

Be certain to fill the pump and/or motor housing with clean hydraulic fluid prior to start up. Fill the housing by pouring filtered oil into the upper case drain port.

Install a 0 to 500 PSI (35 BAR) pressure gauge in the charge pressure gauge port to monitor the charge pressure during start-up.

With the pump swashplate in its neutral (0 angle) position, "jog" or slowly rotate prime mover until charge pressure starts to rise. Start the prime mover and run at the lowest possible RPM until charge pressure has been established. Excess air may be bled from the high pressure lines through the high pressure gauge ports.

WARNING

Do not start prime mover unless pump is in neutral position (0 swashplate angle). Take precautions to prevent machine movement in case pump is actuated during initial start up.

Once charge pressure has been established, increase speed to normal operating RPM. Charge pressure should be 100 PSI (7 BAR) minimum. If charge pressure is incorrect, shut down and determine cause for improper pressure.

With motor output shaft disconnected or drive wheels raised off of the ground, run system at full input and output speeds in both directions. Operate system for at least fifteen (15) minutes.

Shut down prime mover, remove gauges, and plug ports. Check reservoir level and add fluid if necessary.

The transmission is now ready for operation.

Maintenance

To insure optimum service life on Series 40 - M35 products, regular maintenance of the fluid and filter must be performed.

Check the reservoir daily for proper fluid level, the presence of water (noted by a cloudy to milky appearance, or free water in bottom of reservoir), and rancid fluid odor (indicating excessive heat).

It is recommended that the fluid and filter be changed per the vehicle/machine manufacturer's recommendations or at the following intervals:

- System with a sealed type reservoir - 2000 hrs.
- System with a breathing type reservoir - 500 hrs.

It may be necessary to change the fluid more frequently than the above intervals if the fluid becomes contaminated with foreign matter (dirt, water, grease, etc.) or if the fluid has been subjected to temperature levels greater than the maximum recommended. Never reuse fluid.

The filter should be changed whenever the fluid is changed or whenever the filter indicator shows that it is necessary to change the filter.

Troubleshooting

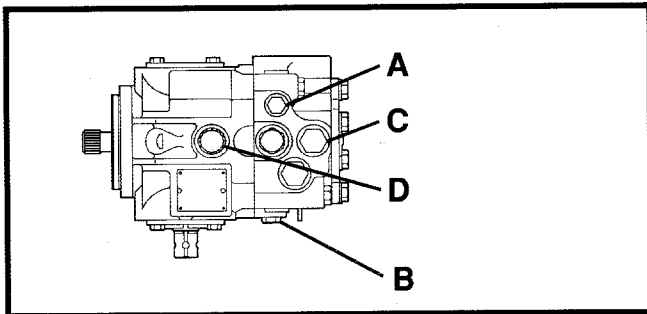

Fig. 8 - Gauge Connections -- Variable Pump (Top View)

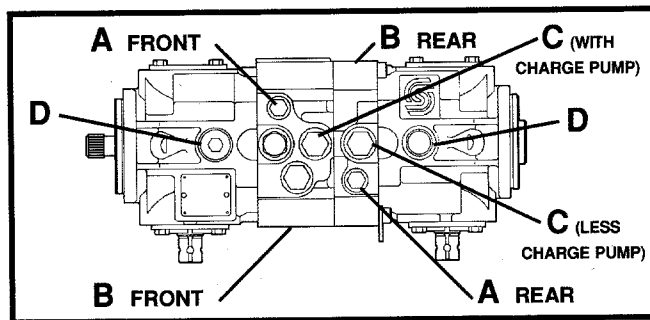

Fig. 9 - Gauge Connections -- Tandem Pump (Top View)

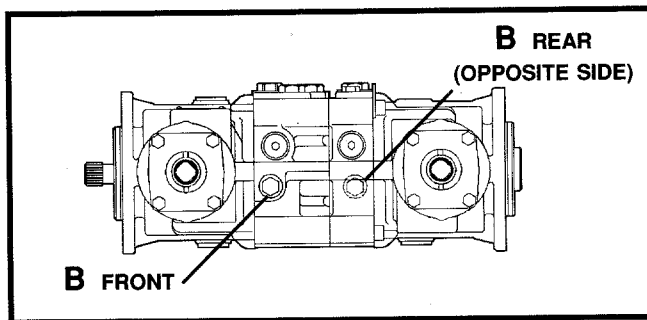

Fig. 10 - Gauge Connections -- Tandem Pump (Side View)

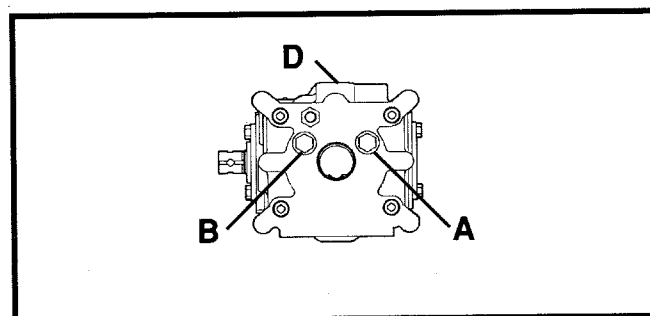

Fig. 11 - Gauge Connections -- Variable Motor (Rear View)

Gauge Installation

Various pressure and vacuum gauge readings can be a great asset in troubleshooting problems with the Series 40 - M35 transmission or support system.

It will be necessary to install a high pressure gauge into the system pressure gauge ports (or tee into the high pressure lines) to check the setting of the system pressure relief valves.

Measuring the charge pump inlet vacuum will help locate restrictions in the inlet lines, filter, etc.

Case pressure readings can help locate restrictions in the return lines, oil cooler, and return filter.

Gauge Information		
A	System Pressure Port "A"	10,000 PSI (690 BAR) - Gauge 9/16 - 18 O-Ring Fitting
B	System Pressure Port "B"	10,000 PSI (690 BAR) - Gauge 9/16 - 18 O-Ring Fitting
C	Charge Pressure	500 PSI (35 BAR) - Gauge Suction Filtration: 7/8 - 14 O-Ring Fitting Pressure Filtration: Tee into Charge Pressure Filter Outlet Line
D	Case Pressure	500 PSI (35 BAR) - Gauge 1-1/16 - 12 O-Ring Fitting (PV, PT, MV) 7/8 - 14 O-Ring Fitting (MF)
E	Charge Pump Inlet Vacuum	Vacuum Gauge Tee into Charge Pump Inlet Line

NOTE: Tandem pumps have two (2) additional system pressure gauge ports (for system ports "C" and "D") in the rear section.

Snubbers are recommended to protect pressure gauges. Frequent gauge calibration is necessary to insure accuracy.

Fault-Logic Diagrams

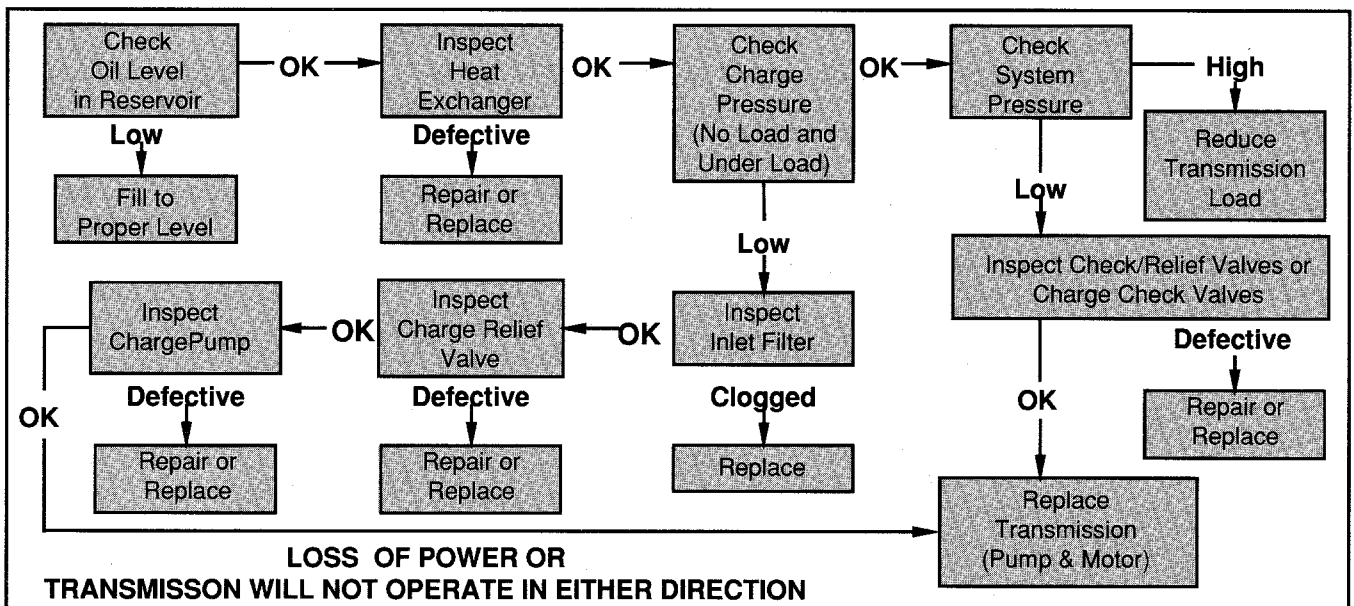
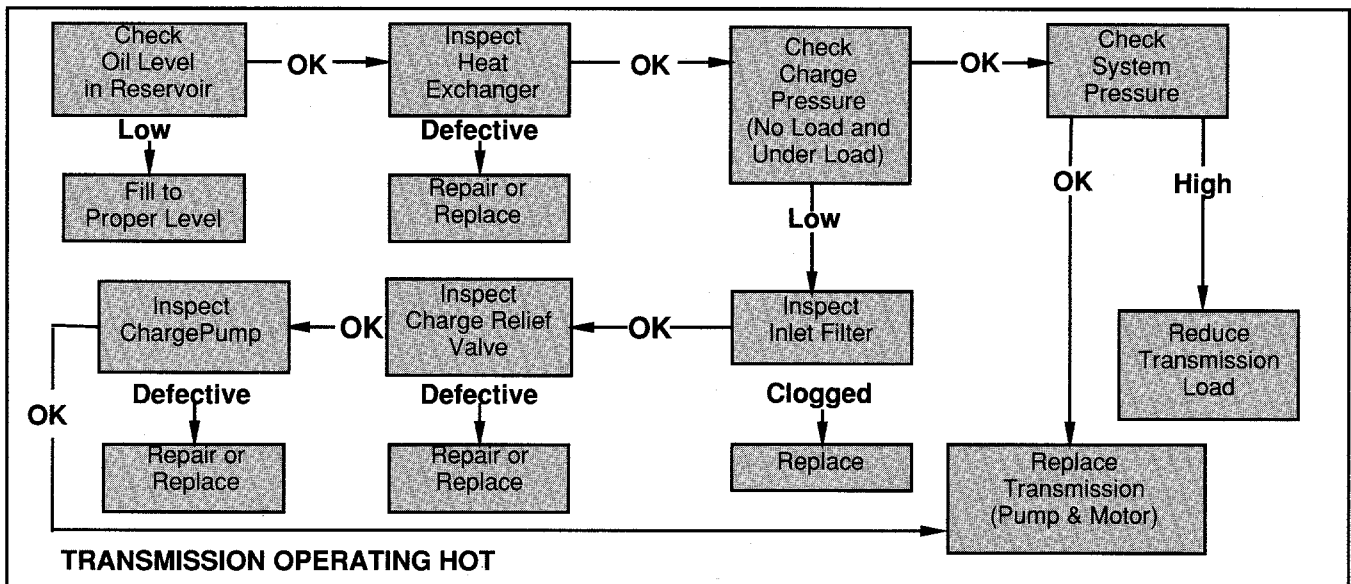
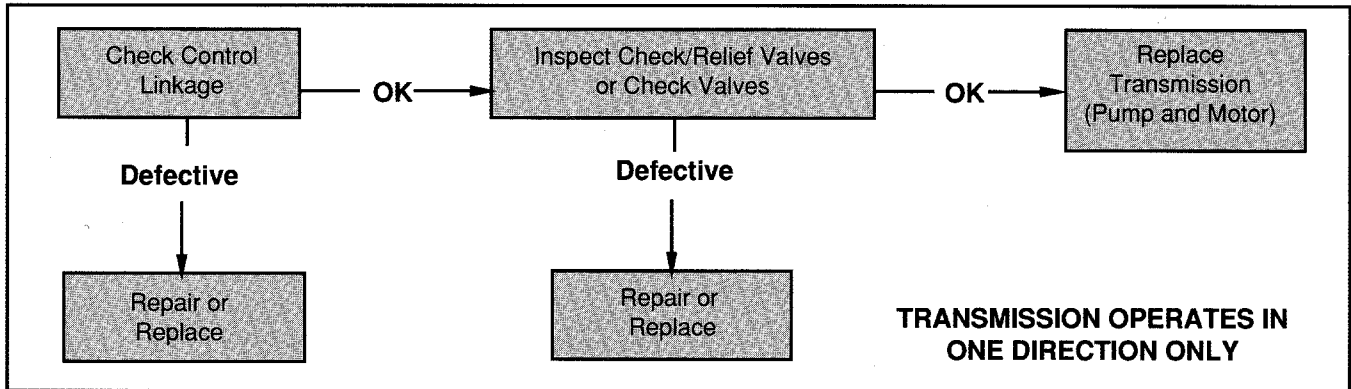

Inspections and Adjustments

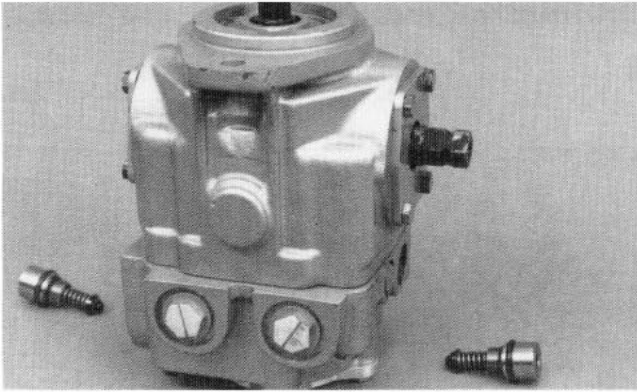

Fig. 12 - Check / High Pressure Relief Valves

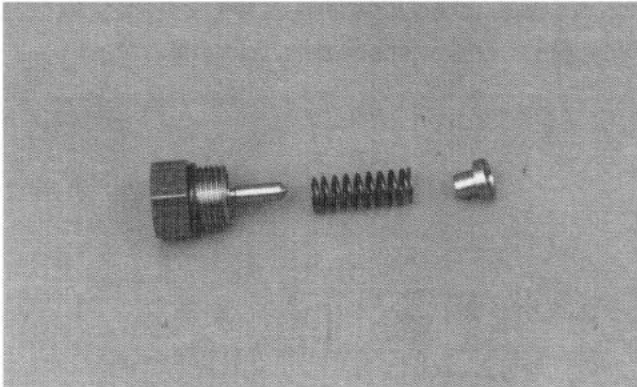

Fig. 13 - Pump Charge Relief Valve

Direct Displacement Control

Inspect the connection of the control linkage to the swashplate control shaft to insure that the linkage is properly attached. Neutral position of the swashplate is determined by the vehicle/machine control linkage.

Check / High Pressure Relief Valves

When a problem occurs in one direction, interchange the charge check or check/relief valves to see if the problem changes to the other direction. If so, one valve is malfunctioning or the check/relief valve cartridge does not have the proper setting.

CAUTION

The relief valves are factory set and should not be tampered with except for replacing the entire cartridge. Disassembly may change the setting and cause erratic unit operation or premature failure.

The pressure setting of the valve (in BAR) is indicated by a three (3) digit code stamped on the cartridge. The cartridge must be removed from the special plug in order to read the code.

Pump Charge Relief Valve

If charge pressure is low, the charge relief valve should be inspected. Inspect for foreign material holding the poppet open, and for scoring or wear on the poppet and seat in the housing.

Adjustment of the charge pressure is accomplished by changing the shim thickness behind the spring. The charge relief valve is factory set for 100 to 120 Δ PSI (7 to 8 BAR) above case pressure at 1800 RPM.

NOTE: Certain M35 pumps have a charge pressure relief valve setting of 200 to 220 Δ PSI (14 to 15 BAR).

Bypass Valve

The bypass function is accomplished by manually opening the charge check / high pressure relief valves. If the system is operating hot, check that the valves are fully seated by turning the special plugs (two [2] on variable pumps, four [4] on tandem pumps) clockwise with a 5/16" internal hex wrench. Torque the plugs to 30 to 50 ft.lbs. (41 to 68 Nm).

Minor Repair and Replacement

General

Minor Repairs may be performed, following the procedures in this section, without voiding the unit warranty.

Cleanliness is a primary means of assuring satisfactory transmission life, on either new or repaired units. Cleaning parts by using a clean solvent wash and air drying is usually adequate. As with any precision equipment, all parts must be kept free of foreign materials and chemicals.

Protect all exposed sealing surfaces and open cavities from damage and foreign material.

It is recommended that all gaskets and O-rings be replaced. Lightly lubricate all O-rings with clean petroleum jelly prior to assembly. All gasket sealing surfaces must be cleaned prior to installing new gaskets.

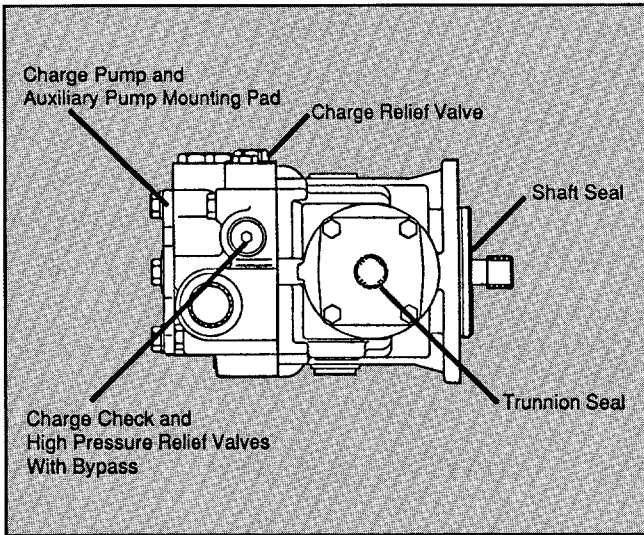

Variable Displacement Pump

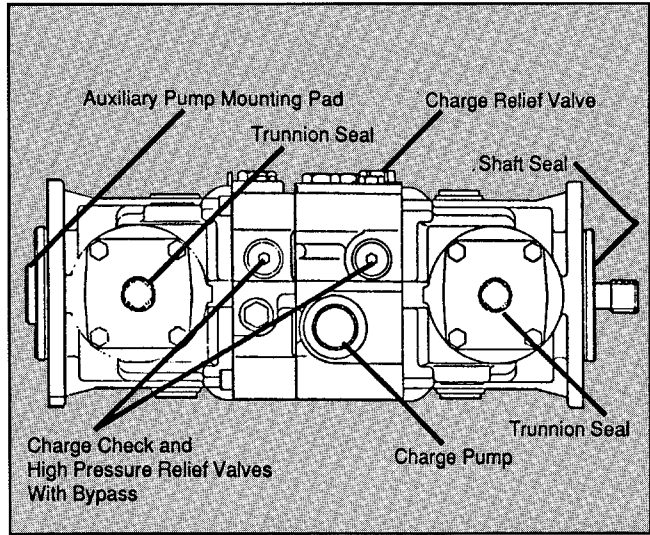

Variable Displacement Tandem Pump

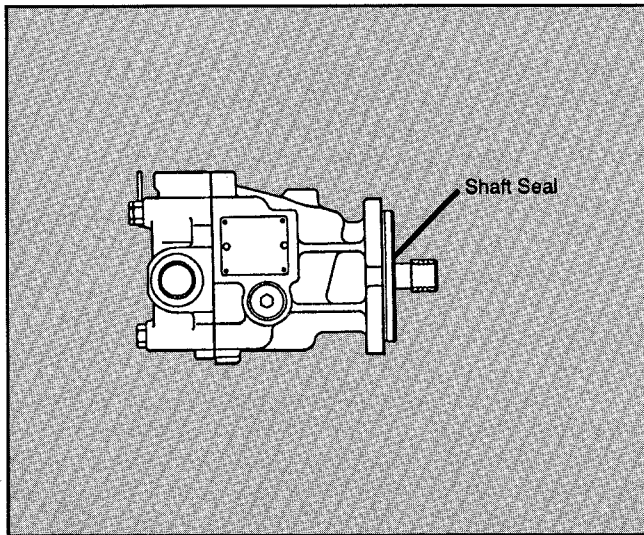

Fixed Displacement Motor

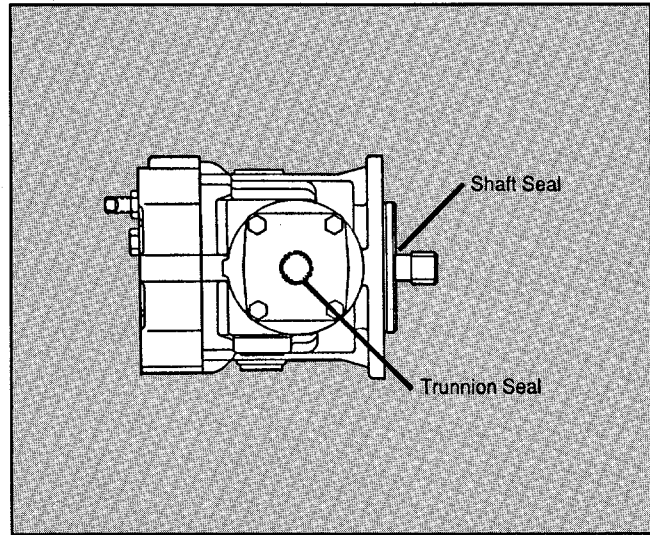

Variable Displacement Motor

Fig. 14 - Minor Repairs

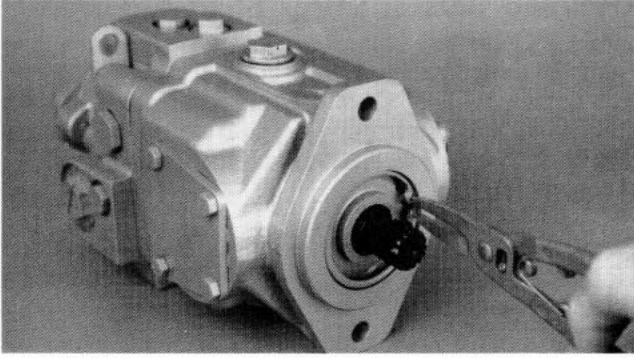

Fig. 15 - Remove Seal Cover Retaining Ring

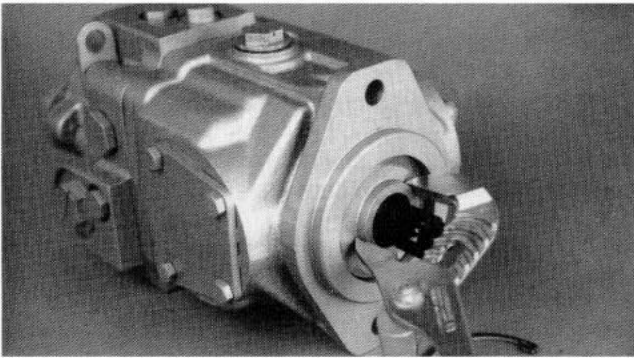

Fig. 16 - Remove Seal Cover from Housing

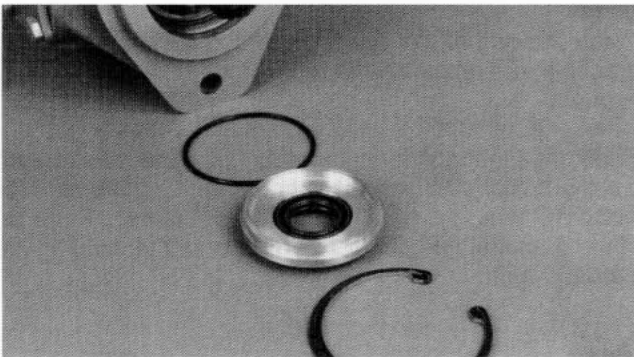

Fig. 17 - Shaft Seal Removed

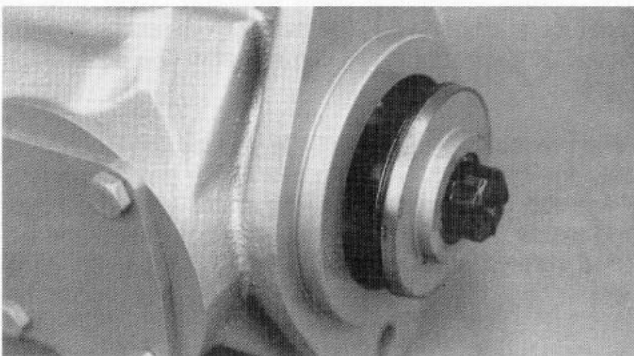

Fig. 18 - Install Seal Cover with O-Ring

Shaft Seal

Lip type shaft seals are used on the Series 40 - M35 pumps and motors. These seals can be replaced without major disassembly of the unit. However, replacement of the shaft seal generally requires removal of the pump or motor from the machine.

Remove the retaining ring from the housing.

Carefully pull the seal cover out of the housing using pliers. Care must be taken so as not to damage the housing bore or shaft.

CAUTION

After the seal cover is removed, the shaft may be free in the housing. **DO NOT PULL SHAFT OUT.** The slipper hold down pins could become dislodged, requiring major disassembly of the unit.

Remove the O-ring from the seal cover or the housing.

Place the seal cover in an arbor press and press out the old seal. An appropriately sized pipe spacer or socket wrench can be used as a press tool. Once removed, the seal is not reusable.

Inspect the seal cover, the new seal, and the O-ring for damage. Inspect the sealing area on the shaft for rust, wear, or contamination. Polish the sealing area on the shaft if necessary.

Using the arbor press, press the new seal into the seal cover. Be careful not to damage seal.

NOTE: New seals are lubricated with an assembly grease

Wrap the spline or key end of shaft with thin plastic to prevent damage to the seal lip during installation.

Install the O-ring onto the seal cover and retain with petroleum jelly.

Slide the seal cover assembly over the shaft and into the housing bore. Install the retaining ring.

NOTE: If a beveled retaining ring is used, install the ring with its beveled side out.

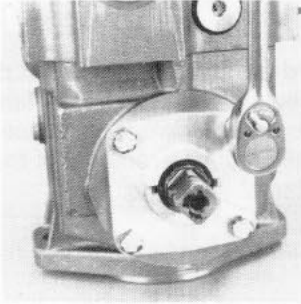

Fig. 19 - Remove Trunnion Seal Carrier

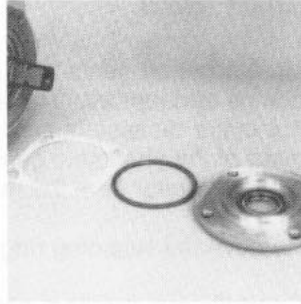

Fig. 20 - Trunnion Seal Carrier and Bearing Shims

Trunnion Seal (Control Shaft Side)

Remove the control linkage from the washplate control shaft. With a 13 mm wrench, remove the hex screws retaining the trunnion seal carrier to the unit housing. Note the position of the seal carrier for reassembly.

Remove the trunnion seal carrier and lip seal, the trunnion bearing shims, and the O-ring. Do not alter the shim thickness.

Place the carrier in an arbor press and press out the old seal. An appropriately sized pipe spacer or socket wrench can be used as a press tool. Once removed, the seal is not reusable.

Inspect the seal cover for damage. Inspect the sealing area on the shaft for rust, wear, or contamination. Polish the sealing area on the shaft if necessary.

Using the arbor press, press the new seal into the seal carrier. Be careful not to damage seal.

NOTE: New seals are lubricated with an assembly grease

Place the the trunnion bearing shims onto the seal carrier, and retain with petroleum jelly.

Install the O-ring into the housing bore, and retain with petroleum jelly.

Wrap the end of the washplate control shaft with thin plastic to prevent damage to the seal lip during installation.

Slide the seal carrier assembly over the washplate control shaft and onto the housing. Install the hex head screws and torque to 18 to 22 ft.lbs. (24 to 30 Nm). Reinstall the control linkage onto the washplate control shaft.

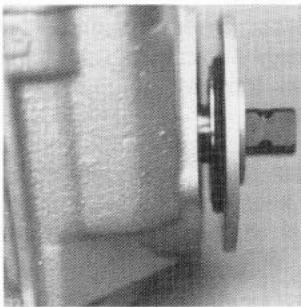

Fig. 21 - Install Trunnion Seal Carrier

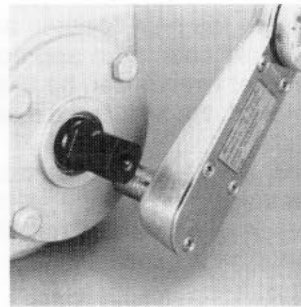

Fig. 22 - Torque Trunnion Seal Carrier Screws

Trunnion Cover (Plain)

The O-ring under the plain trunnion cover may be replaced after removing the hex screws, cover, bearing shims, and spacer ring. Do not alter the shim thickness.

When reassembling, install the spacer ring and O-ring onto the housing, retaining them with petroleum jelly. Place the the trunnion bearing shims onto the cover, and install the cover onto the housing. Install the hex head screws and torque to 18 to 22 ft.lbs. (24 to 30 Nm).

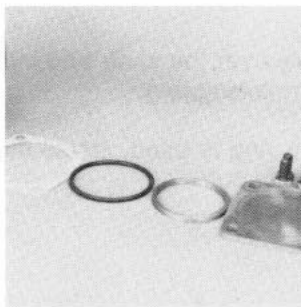

Fig. 23 - Plain Trunnion Cover Components

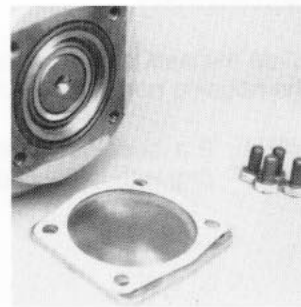

Fig. 24 - Install Spacer Ring and O-Ring in Housing

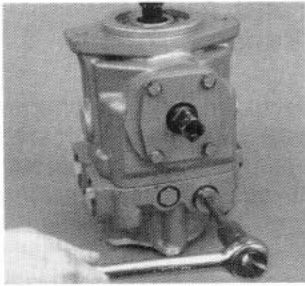

Fig. 25 - Remove Check and Relief Valve Plug (PV)

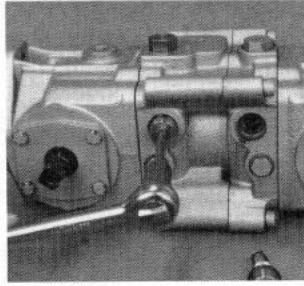

Fig. 26 - Remove Check and Relief Valve Plug (PT)

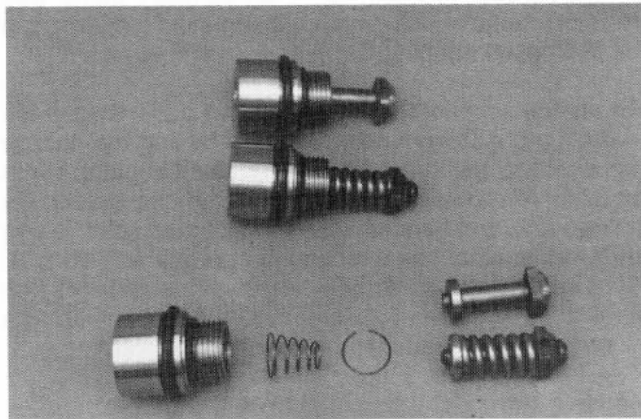

Fig. 27 - Check and Relief Valve Components

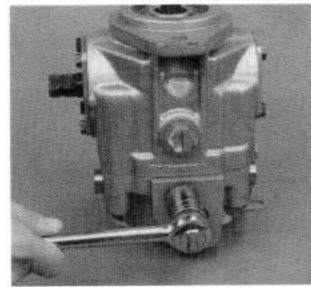

Fig. 28 - Remove Charge Relief Valve Plug (PV)

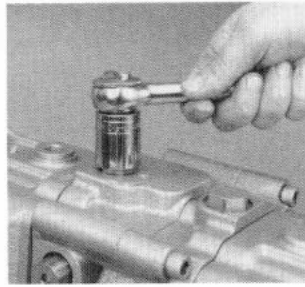

Fig. 29 - Remove Charge Relief Valve Plug (PT)

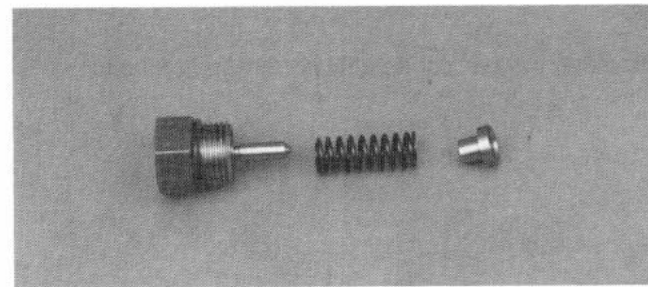

Fig. 30 - Charge Relief Valve Components

Check and High Pressure Relief Valves

Remove the check and high pressure relief valves with a 5/16" internal hex wrench.

Remove the valve cartridge assembly from the pump end cap. Inspect the valve and mating seat in the end cap for damage or foreign material.

The check poppet or relief valve is retained in the special plug by a circlip. The poppet or valve and check valve spring may be removed from the special plug by pulling straight out. When reassembling, install the check valve spring into the special plug with its larger diameter toward the plug, and snap the poppet or valve into position in the plug.

Reinstall the valve cartridge (with O-rings) into the end cap. Torque the plug to 30 to 50 ft.lbs. (41 to 68 Nm).

CAUTION

The relief valves are factory set and should not be tampered with except for replacing the entire valve.

Charge Pressure Relief Valve

Remove the charge relief valve hex plug with a 1" wrench.

Remove the spring and poppet from the end cap.

CAUTION

Do not allow the poppet to fall into the pump housing.

Do not alter the shims (which may be installed between the spring and valve plug) or interchange parts with another valve. Inspect the poppet and mating seat in the end cap for damage or foreign material.

Reinstall the poppet, spring, and plug (with shims and O-ring) into the end cap. Torque the plug to 40 to 100 ft.lbs. (54 to 135 Nm).

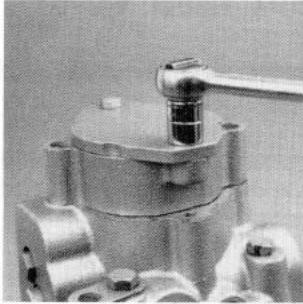

Fig. 31 - Remove Flange Cover

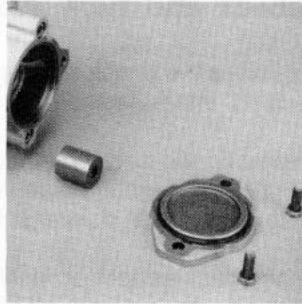

Fig. 32 - Auxiliary Pad Components

Integral Charge Pump and Auxiliary Pump Mounting Pad (Variable Pump)

NOTE: Variable Pumps without an integral charge pump have the charge pump inlet port and gerotor cavity outlet plugged, and no gerotor assembly installed. Procedures for removing and installing the charge pump cover or auxiliary mounting pad are similar to those for units with an integral charge pump.

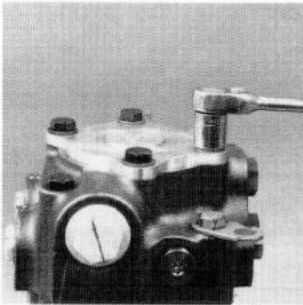

Fig. 33 - Remove Charge Pump Cover

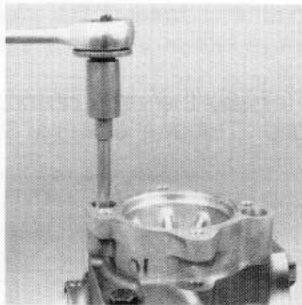

Fig. 34 - Remove Pad Adapter

If the unit is equipped with an auxiliary pump mounting pad, remove the two (2) screws retaining the flange cover or auxiliary pump. Remove the flange cover or auxiliary pump and O-ring. If an auxiliary pump was installed, remove the drive coupling (and retaining pin for 13T spline coupling).

On pumps with no auxiliary mounting pad, remove the four (4) hex screws and washers retaining the charge pump cover, using a 17 mm wrench. On pumps with an SAE "A" auxiliary mounting pad, remove the two (2) screws and washers retaining the pad adapter, using an 8 mm internal hex wrench. On pumps with an SAE "B" auxiliary mounting pad, remove the four (4) hex screws and washers retaining the pad adapter, using a 17 mm wrench. Remove the cover or adapter.

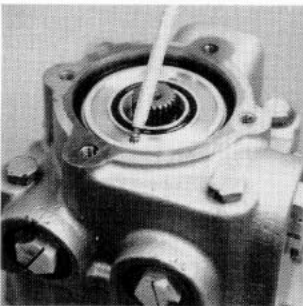

Fig. 35 - Remove Gerotor Spacer Check Ball

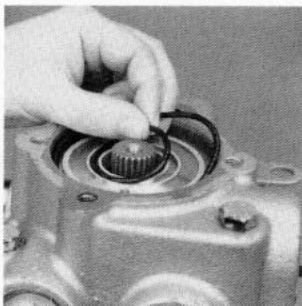

Fig. 36 - Remove Gerotor Spacer O-Rings

Remove the steel check ball from the gerotor spacer with a magnet.

Remove the two (2) gerotor spacer O-rings.

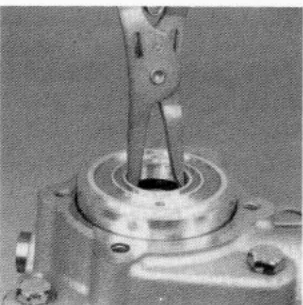

Fig. 37 - Remove Gerotor Spacer

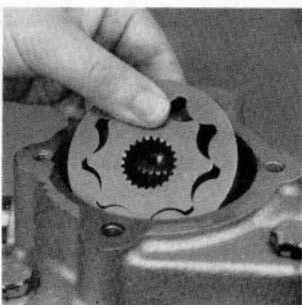

Fig. 38 - Remove Gerotor Assembly

Lift the gerotor spacer (with its locating pin) out of the end cap using a large pair of retaining ring pliers. Take care to avoid damaging the gerotor spacer. Note the orientation of the gerotor spacer and pin for reassembly.

Remove the gerotor assembly from the end cap.

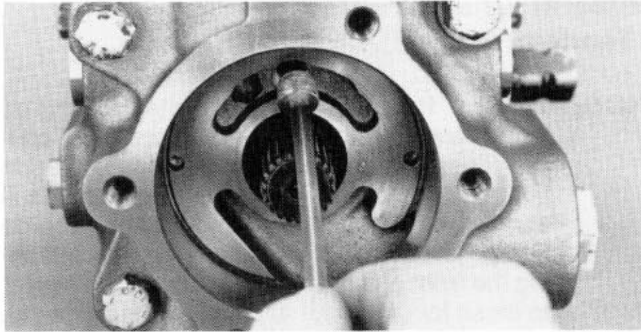

Fig. 39 - Remote Pressure Filtration Pipe Plug

If the pump is equipped for remote pressure filtration or is not equipped with an integral charge pump, a pipe plug will be installed in the threaded hole in the end cap gerotor cavity. This plug must not be installed if the pump is used with suction filtration. The plug may be removed with a 1/4" internal hex wrench. When reinstalling, use a thread locking compound on the plug and torque to 45 to 50 ft.lbs. (61 to 68 Nm).

Each part should be inspected separately if they are to be reused. If either of the gerotor assembly parts needs to be replaced, they must both be replaced. Always replace the O-rings.

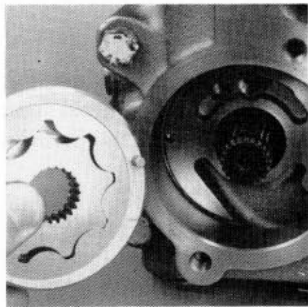

Fig. 40 - Orienting Gerotor Spacer and Pin (CW)

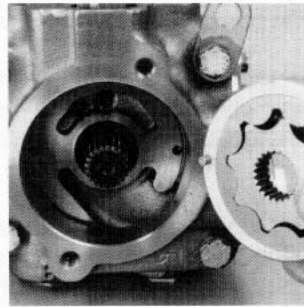

Fig. 41 - Orienting Gerotor Spacer and Pin (CCW)

Prior to assembly, lubricate the gerotor assembly with clean hydraulic oil.

Slide the gerotor assembly into position on the shaft spline.

NOTE: The charge pump rotation is determined by the position of the gerotor spacer and locating pin in the pump end cap.

Install the gerotor spacer (with locating pin), over the gerotor assembly and into the pump end cap, orienting them for the proper input shaft rotation direction. The pin in the gerotor spacer should be located in the end cap hole farthest away from the the charge pump inlet port for clockwise (CW) input rotation, and closest to the inlet port for counterclockwise (CCW) input rotation.

Install the two (2) O-rings into the grooves of the gerotor spacer.

Install the steel check ball into the gerotor spacer. The ball must always be located next to the inlet side of the charge pump to allow balance pressure to build up on the gerotor spacer.

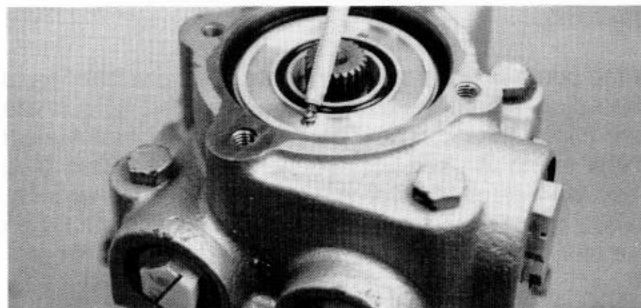

Fig. 42 - Location of Check Ball in Gerotor Spacer

Reinstall the charge pump cover or auxiliary pad adapter, and torque the screws to 35 to 45 ft.lbs. 47 to 61 Nm).

If the unit is equipped with an auxiliary pump mounting pad, install the O-ring, coupling (if used), and flange cover or auxiliary pump.

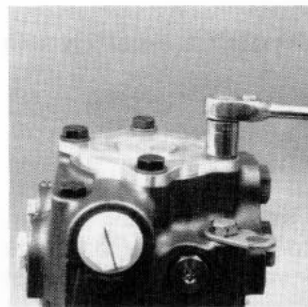

Fig. 43 - Installing Charge Pump Cover

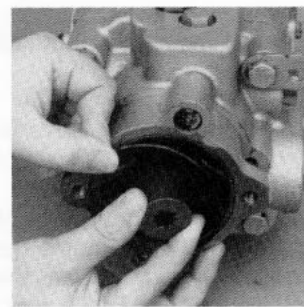

Fig. 44 - Installing Auxiliary Drive Coupling and O-Ring

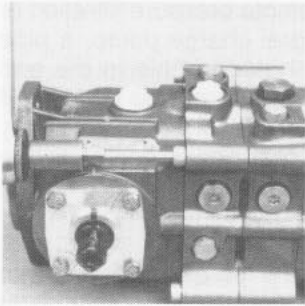

Fig. 45 - Separate Pump Sections

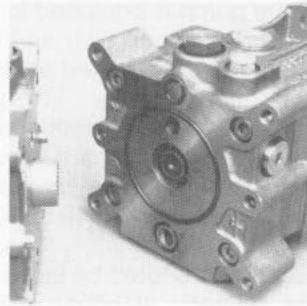

Fig. 46 - Remove O-Rings

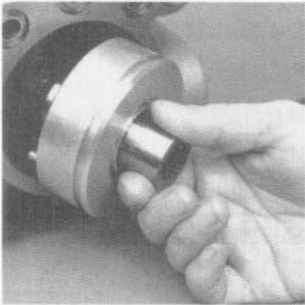

Fig. 47 - Remove Gerotor Assembly

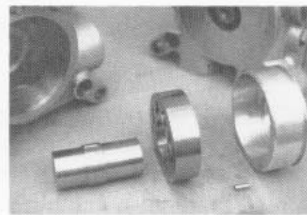

Fig. 48 - Charge Pump Components

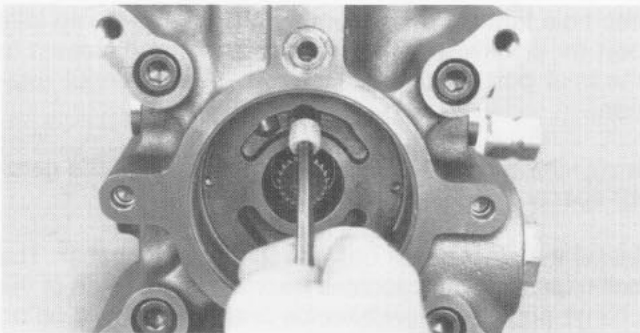

Fig. 49 - Remote Pressure Filtration Pipe Plug

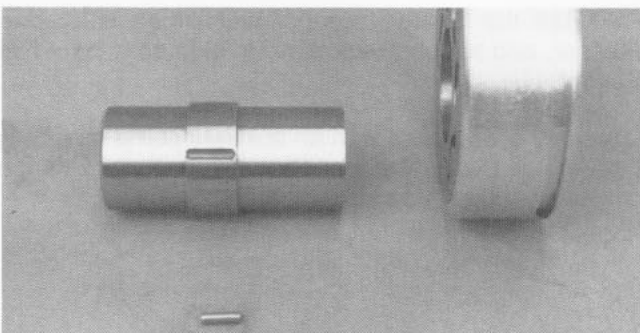

Fig. 50 - Charge Pump Drive Pin and Coupling

Integral Charge Pump (Tandem Pump)

NOTE: Tandem Pumps without an integral charge pump have O-ring seals and a short drive coupling installed between the sections. In addition, the end cap for the front pump section is thinner and is not machined to accept a charge pump. Procedures for separating and attaching the front and rear pump sections are similar to those for units with an integral charge pump.

Remove the four (4) screws (using an 8 mm internal hex wrench) which retain the front and rear pump sections together. Separate the front and rear sections of the pump. Remove the two (2) alignment pins.

Remove the two (2) small O-rings from the front section end cap. Remove the single large O-ring (units less charge pump), or the two (2) gerotor spacer O-rings (units with charge pump).

For units less charge pump, remove the shaft coupling. For units with charge pump, remove the shaft coupling with the gerotor assembly, gerotor spacer, and locating pin, from the front section. Note the orientation of the gerotor spacer and pin for reassembly.

Separate the shaft coupling and gerotor assembly from the gerotor spacer. Remove the drive pin from the coupling.

If the pump is equipped for remote pressure filtration, a pipe plug will be installed in the threaded hole in the end cap gerotor cavity. This plug must not be installed if the pump is used with suction filtration. This plug may be removed with a 1/4" internal hex wrench. When reinstalling, use a thread locking compound on the plug and torque to 45 to 50 ft.lbs. (61 to 68 Nm).

Each part should be inspected separately if they are to be reused. If either of the gerotor assembly parts needs to be replaced, they must both be replaced. Always replace the O-rings.

Prior to assembly, lubricate the gerotor assembly with clean hydraulic oil.

Install the gerotor drive pin in the groove in the coupling, and retain with petroleum jelly.

Install the gerotor assembly into the gerotor spacer. Install the assembled gerotor and spacer onto the coupling, being certain the drive pin engages the slot in the gerotor. The longer portion of the coupling must be installed toward the spacer (toward the rear pump section).

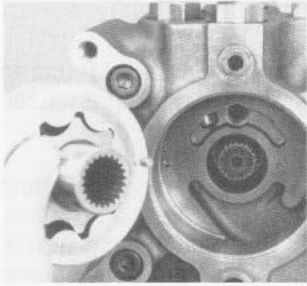

Fig. 51 - Orienting Gerotor Spacer and Pin (CW)

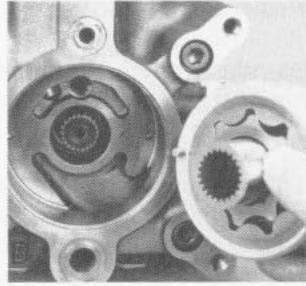

Fig. 52 - Orienting Gerotor Spacer and Pin (CCW)

Install the locating pin into the gerotor spacer.

NOTE: The charge pump rotation is determined by the position of the gerotor spacer and locating pin in the front pump end cap.

Install the gerotor spacer (with locating pin, gerotor assembly, and drive coupling), into the front pump end cap, orienting the spacer for the proper input shaft rotation direction. The pin in the gerotor spacer should be located in the end cap hole farthest away from the the charge pump inlet port for clockwise (CW) input rotation, and closest to the inlet port for counterclockwise (CCW) input rotation.

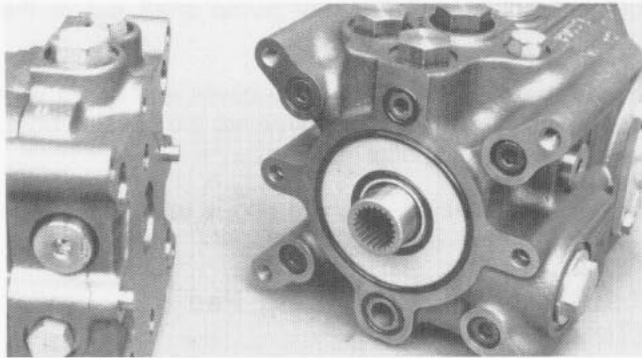

Fig. 53 - O-Rings Installed Between Sections

For units less charge pump, install the shaft coupling onto the front pump shaft.

Install the two (2) small O-rings into the front section end cap. Install the single large O-ring into the front section end cap (units less charge pump), or the two (2) O-rings into the grooves of the gerotor spacer (units with charge pump).

Install the two (2) alignment pins into the rear section end cap.

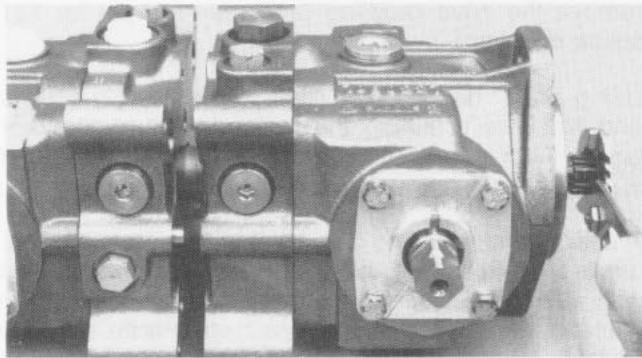

Fig. 54 - Rotating Shaft to Align Splines

Slide the front and rear sections of the pump together, rotating the front pump shaft to align the splines on the coupling and rear pump shaft.

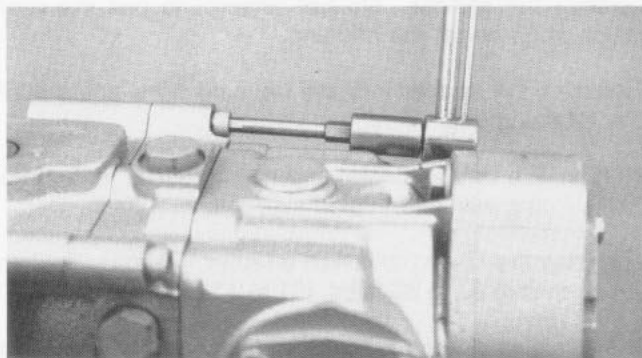

Fig. 55 - Torque Retaining Screws

Install the four (4) socket head screws to retain the front and rear pump sections together. Torque the screws to 35 to 45 ft.lbs. (47 to 61 Nm). Check for proper internal assembly by slowly rotating the pump shaft while tightening these screws.

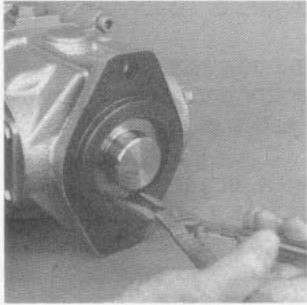

Fig. 56 - Removing Retaining Ring

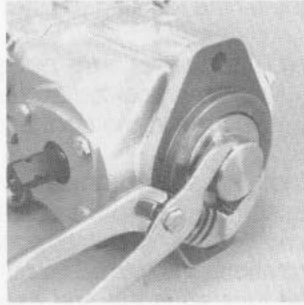

Fig. 57 - Removing Cover

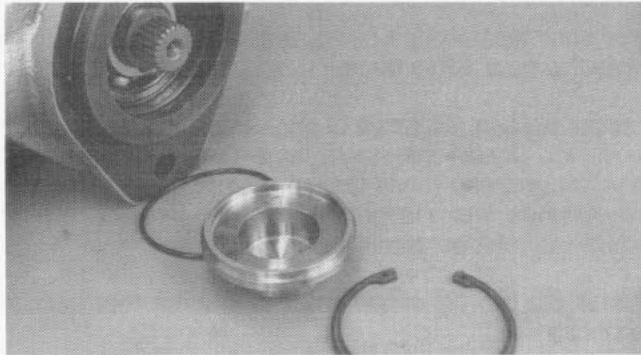

Fig. 58 - Rear Shaft Cover Removed

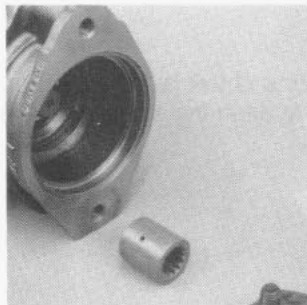

Fig. 59 - Remove Cover and Coupling

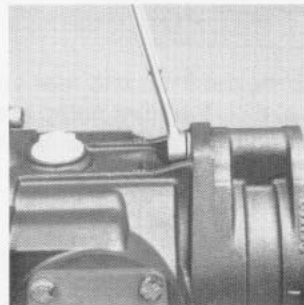

Fig. 60 - Remove Pad Adapter

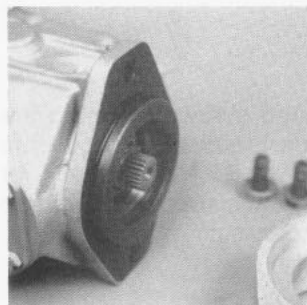

Fig. 61 - Rear Pump Housing (Auxiliary Pad Removed)

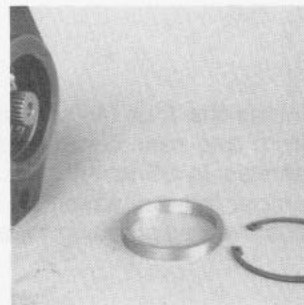

Fig. 62 - Bearing Spacer and Retaining Ring

Rear Shaft Cover (Tandem Pump)

Standard tandem pumps use the same rear pump housing and shaft for all units, with or without an auxiliary pump mounting pad.

Tandem pumps without an auxiliary pump mounting pad have a cover installed over the rear pump shaft. This cover is held in place by a retaining ring and is sealed by an O-ring. The cover retains the rear pump shaft in its housing.

Remove the retaining ring from the housing and carefully pull the cover out of the housing using pliers. Remove the O-ring from the cover or the housing. Do not attempt to pull the rear pump shaft out of the housing.

Install the new O-ring onto the cover and retain with petroleum jelly. Press the cover into the housing bore. Install the retaining ring.

NOTE: If a beveled retaining ring is used, install the ring with its beveled side out.

Auxiliary Pump Mounting Pad (Tandem Pump)

Remove the two (2) screws retaining the flange cover or auxiliary pump, and remove the cover or pump with its sealing O-ring. If an auxiliary pump was installed, remove the drive coupling (and retaining pin for 13T spline coupling).

Using a 3/4" hex wrench, remove the two (2) screws and washers retaining the pad adapter to the rear pump housing, and remove the adapter. The adapter is sealed to the rear pump housing with an O-ring.

A spacer and retaining ring are used to retain the rear pump shaft in its housing on tandem pumps equipped with auxiliary pads. This spacer must be installed in place of the shaft cover before installing an auxiliary pad.

Remove the retaining ring from the housing and remove the spacer. Do not attempt to pull the rear pump shaft out of the housing.

Reinstall the spacer into the housing bore and install the retaining ring.

NOTE: If a beveled retaining ring is used, install the ring with its beveled side out.

Reinstall the O-ring and pad adapter. Torque the two (2) screws to 67 to 82 ft.lbs. (91 to 111 Nm).

If an auxiliary pump is to be installed, install the drive coupling (with retaining pin for 13T spline coupling). Install the O-ring and flange cover or auxiliary pump.

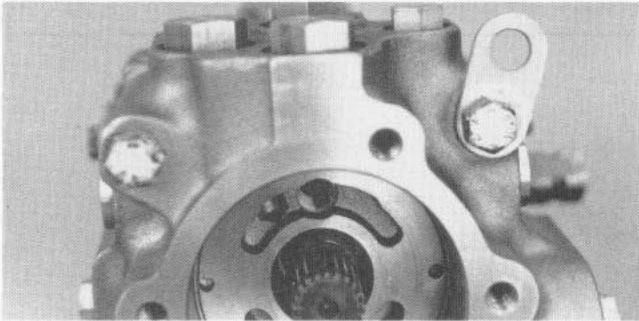

Fig. 63 - Plug Locations for Suction Filtration (PV Shown, PT Similar)

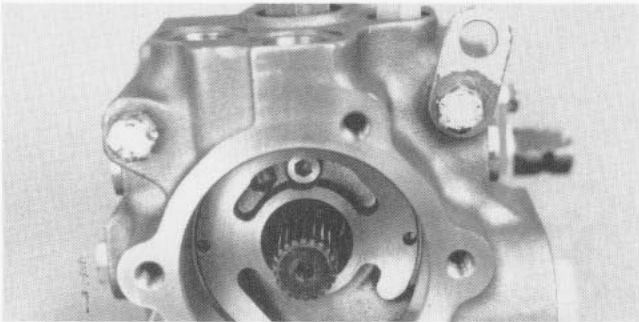

Fig. 64 - Plug Locations for Remote Pressure Filtration (PV Shown, PT Similar)

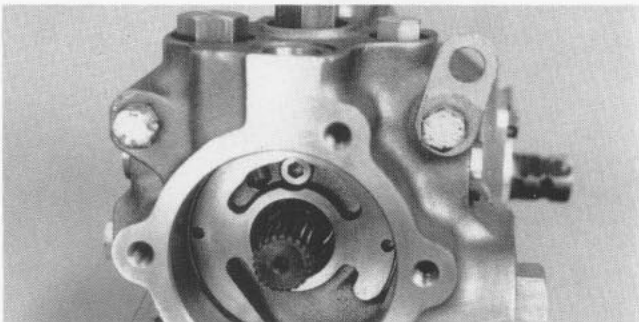

Fig. 65 - Plug Locations for PV Less Charge Pump

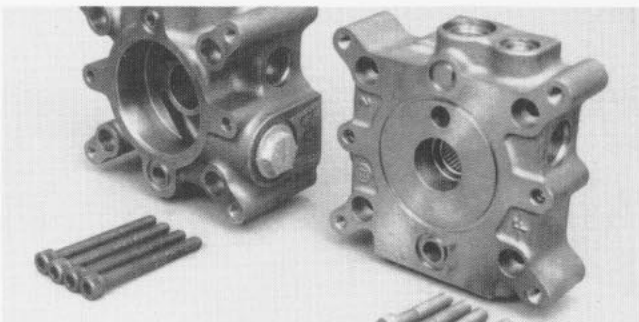

Fig. 66 - Tandem Pump (PT) Front Section End Caps

Filtration and Charge Pump Options

Variable pumps and tandem pumps with integral charge pumps equipped for suction filtration have two (2) plugs installed in the remote filter ports in the end cap. In addition, a pipe plug is NOT installed in the threaded hole in the end cap gerotor cavity.

Variable pumps and tandem pumps with integral charge pumps equipped for remote pressure filtration do not have plugs installed in the remote filter ports in the end cap. In addition, a pipe plug is installed in the threaded hole in the end cap gerotor cavity.

Variable pumps without integral charge pumps have a plug installed in the remote filter outlet port in the end cap. In addition, a pipe plug is installed in the threaded hole in the end cap gerotor cavity, and the charge pump inlet port in the end cap is plugged.

Tandem pumps without integral charge pumps use a thinner end cap for the front pump section, which is not machined to accept a charge pump. A shorter drive coupling and shorter screws are also used.

NOTE: Removal of the end cap is considered to be a Major Repair, which may affect the unit warranty status. Major Repairs are to be performed only by Sundstrand-Sauer Authorized Service Centers and/or original equipment manufacturers who have been adequately trained by Sundstrand-Sauer.

General Parts Identification

The following Information is for general parts identification ONLY. Refer to the applicable Service Parts List when ordering service parts

M35 Variable Displacement Pump -- PV (Minor Repair)

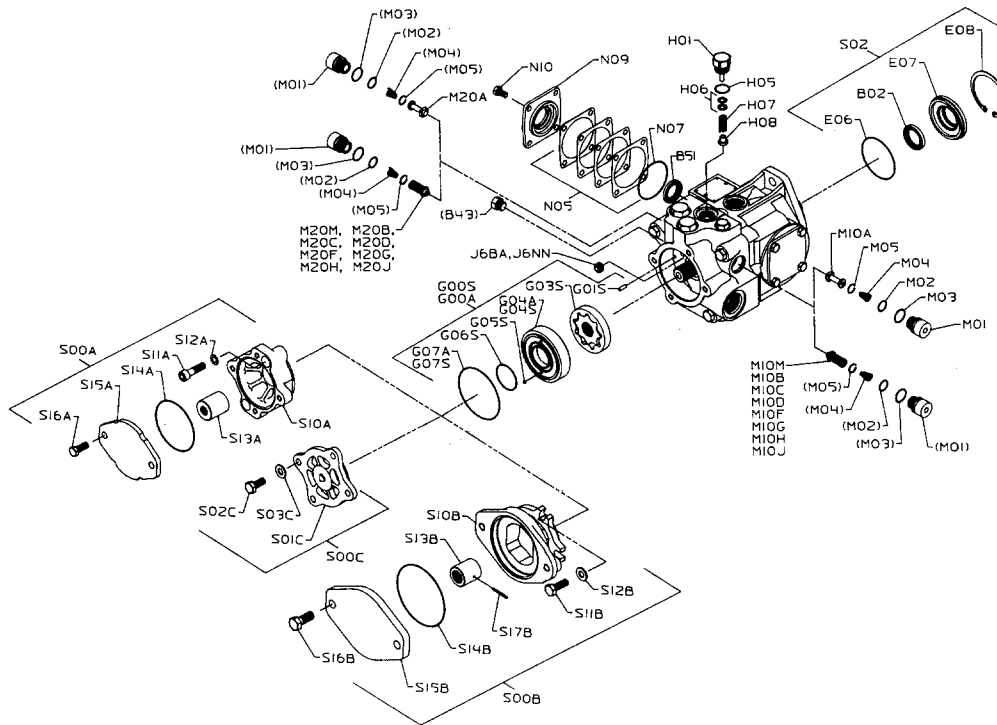

M35 Variable Displacement Pump -- PV (Minor Repair)

COMMON PARTS		
ITEM	DESCRIPTION	QTY
B02	SEAL-LIP	1
B43	PLUG ST THD	2
B45	PLUG ST THD	1
B51	SEAL-LIP	1
E06	O-RING	1
E07	CARRIER-SEAL	1
E08	RING RETG	1
H01	PLUG ASSY-CHG RELIEF	1
H05	O-RING	1
H06	SHIM-CHG. RELIEF	1
H07	SPRING-COMPRESSION	1
H08	POPPET-CHG.RELIEF	1
M01	PLUG-SPECIAL	2
M02	O-RING	2
M03	O-RING	4
M04	SPRING-CONICAL COMP	2
M05	RING-RETAINING	2
N05	SHIM-TRUNNION	1
N06	SPACER	1
N07	O-RING	2
N08	COVER-TRUNNION	1
N09	CARRIER-TRUNNION SEAL	1
N10	SCREW	8

RELIEF VALVE GROUP		
ITEM	DESCRIPTION	QTY
M10A	POPPET-CHECK VALVE	1
M20A	POPPET-CHECK VALVE	1
M10B	VALVE-RELIEF	1
M20B	VALVE-RELIEF	1
M10C	VALVE-RELIEF	1
M20C	VALVE-RELIEF	1
M10D	VALVE-RELIEF	1
M20D	VALVE-RELIEF	1
M10F	VALVE-RELIEF	1
M20F	VALVE-RELIEF	1
M10G	VALVE-RELIEF	1
M20G	VALVE-RELIEF	1
M10H	VALVE-RELIEF	1
M20H	VALVE-RELIEF	1
M10J	VALVE-RELIEF	1
M20J	VALVE-RELIEF	1
M10M	VALVE-RELIEF	1
M20M	VALVE-RELIEF	1

FILTRATION GROUP		
ITEM	DESCRIPTION	QTY
J7AA	PLUG ST THD	1
J6BA	PLUG PIPE	1
J2NN	PLUG ST THD	1
J5AA	PLUG ST THD	1
J6NN	PLUG PIPE	1
J7NN	PLUG ST THD	1

SHAFT GROUP		
ITEM	DESCRIPTION	QTY
E02N	KEY	1
E02Y	KEY SQUARE	1

CHARGE PUMP GROUP		
ITEM	DESCRIPTION	QTY
G04A	SPACER-GEROTOR (NO C P)	1
G07A	O-RING	1
G01S	PIN ST HDLS (11.8 CC/REV)	1
G03S	GEROTOR ASSY	1
G04S	SPACER-GEROTOR	1
G05S	BALL	1
G06S	O-RING	1
G07S	O-RING	1

AUXILIARY FLANGE GROUP		
ITEM	DESCRIPTION	QTY
S10A	ADPT. SAE "A" FLANGE (9T)	1
S11A	SCREW-SOC HD METRIC	2
S12A	WASHER-SPECIAL	2
S13A	COUPLING	1
S14A	O-RING	1
S15A	PLATE COVER	1
S16A	SCREW HEX HD	2
S10B	ADPT SAE "B" FLANGE (13T)	1
S11B	SCREW-HEX HD METRIC	4
S12B	WASHER	4
S13B	COUPLING	1
S14B	O-RING	1
S15B	COVER "B" FLANGE	1
S16B	SCREW HEX HD	2
S17B	PIN SPG	1
S01C	COVER-GEROTOR (NO ADPT)	1
S02C	SCREW-HEX HD METRIC	4
S03C	WASHER	4

M35 Tandem Pump -- PT (Minor Repair)

COMMON PARTS		
ITEM	DESCRIPTION	QTY
B02	SEAL-LIP	1
B43	PLUG, ST THD	4
B45	PLUG, ST THD	2
B50	SCREW, SOCKET HD METRIC	4
B51	SEAL, LIP	2
E06	O-RING	1
E07	CARRIER, SEAL	1
E08	RING, RETG	2
G05	O-RING	1
G10	O-RING	1
H01	PLUG ASSY, CHG RELIEF	1
H05	O-RING	1
H06	SHIM, CHG. RELIEF	1
H07	SPRING, COMPRESSION	1
H08	POPPET, CHG.RELIEF	1
M01	PLUG, SPECIAL	4
M02	O-RING	4
M03	O-RING	4
M04	SPRING, CONICAL COMP	4
M05	RING, RETAINING	4
N05	SHIM, TRUNNION	4
N06	SPACER	2
N07	O-RING	4
N08	COVER, TRUNNION	2
N09	CARRIER, TRUNNION SEAL	2
N10	SCREW	6

RELIEF VALVE GROUP		
ITEM	DESCRIPTION	QTY
M10A	POPPET-CHECK VALVE	1
M20A	POPPET-CHECK VALVE	1
M10B	VALVE, RELIEF	1
M20B	VALVE, RELIEF	1
M10C	VALVE, RELIEF	1
M20C	VALVE, RELIEF	1
M10D	VALVE-RELIEF	1
M20D	VALVE-RELIEF	1
M10F	VALVE-RELIEF	1
M20F	VALVE-RELIEF	1
M10G	VALVE-RELIEF	1
M20G	VALVE-RELIEF	1
M10H	VALVE-RELIEF	1
M20H	VALVE-RELIEF	1
M10J	VALVE-RELIEF	1
M20J	VALVE-RELIEF	1
M10M	VALVE-RELIEF	1
M20M	VALVE-RELIEF	1

FILTRATION GROUP		
ITEM	DESCRIPTION	QTY
J5AA	PLUG, ST THD	2
J7AA	PLUG, ST THD	1

SHAFT GROUP		
ITEM	DESCRIPTION	QTY
E02C	KEY	1

CHARGE PUMP GROUP		
ITEM	DESCRIPTION	QTY
G07A	O-RING (NO CHARGE PUMP)	1
G08A	SCREW SOCKET HD METRIC	4
G09A	COUPLING	1
G01S	PIN, ST HDLS (11.8 CC/REV)	1
G02S	PIN, STRAIGHT	1
G03S	GEROTOR ASSY	1
G04S	SPACER-GEROTOR	1
G06S	O-RING	1
G07S	O-RING	1
G08S	SCREW SOCKET HD METRIC	4
G09S	COUPLING	1
G01R	PIN, ST HDLS (16.4 CC/REV)	1
G02R	PIN, STRAIGHT	1
G03R	GEROTOR ASSY	1
G04R	SPACER-GEROTOR	1
G06R	O-RING	1
G07R	O-RING	1
G08R	SCREW SOCKET HD METRIC	4
G09R	COUPLING	1

AUXILIARY FLANGE GROUP		
ITEM	DESCRIPTION	QTY
S07A	PLUG ST THD	1
S10A	ADPT. SAE "A" FLANGE (9T)	1
S11A	SCREW-HEX HD	2
S12A	WASHER	2
S13A	COUPLING	1
S14A	O-RING	1
S15A	PLATE COVER	1
S16A	SCREW HEX HD	2
S18A	SPACER	1
S19A	O-RING	1
S07B	PLUG ST THD	1
S10B	ADPT. SAE "B" FLANGE (13T)	1
S11B	SCREW-HEX HD	2
S12B	WASHER	2
S13B	COUPLING	1
S14B	O-RING	1
S15B	'B' FLANGE COVER	1
S16B	SCREW HEX HD	2
S17B	PIN SPG	1
S18B	SPACER	1
S19B	O-RING	1
S04C	FLANGE COVER (NO ADPT.)	1
S05C	O-RING	1
S07C	PLUG	1
S13Z	COUPLING	1
S14Z	O-RING	1
S15Z	GEAR PUMP	1
S16Z	SCREW HEX HD	2

M35 Fixed Displacement Motor -- MF (Minor Repair)

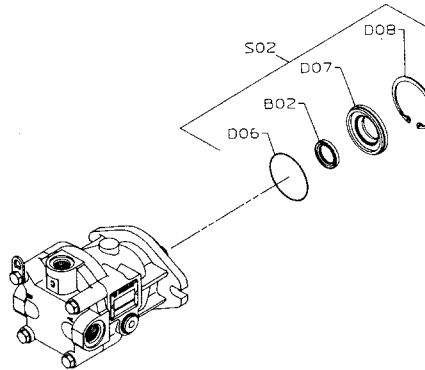

COMMON PARTS		
ITEM	DESCRIPTION	QTY
B02	SEAL-LIP	1
B44	PLUG, PLASTIC	2
B45	PLUG	1
B47	PLUG, PLASTIC	1
D06	O-RING	1
D07	CARRIER-SEAL	1
D08	RING, RETAINING	1

OUTPUT SHAFT/AUXILIARY DRIVE GROUP		
ITEM	DESCRIPTION	QTY
D02N	KEY	1
D02S	KEY SQUARE	1

END CAP GROUP		
ITEM	DESCRIPTION	QTY
E02C	SEAL LIP	1
E12C	RING RETAINING	1

M35 Variable Displacement Motor -- MV (Minor Repair)

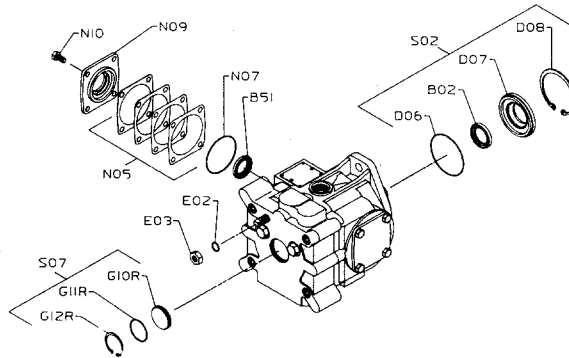

COMMON PARTS		
ITEM	DESCRIPTION	QTY
B02	SEAL-LIP	1
B44	PLUG PLASTIC	3
B45	PLUG ST THD	1
B48	PLUG ST THD	2
B51	SEAL-LIP	1
D06	O-RING	1
D07	CARRIER-SEAL	1
D08	RING RETG	1
E03	NUT, METRIC JAM	1
N05	SHIM, TRUNNION	1
N06	SPACER	1
N07	O-RING	2
N08	COVER, TRUNNION	1

COMMON PARTS (CONT)		
ITEM	DESCRIPTION	QTY
N09	CARRIER, TRUNNION SEAL	1
N10	SCREW	8

OUTPUT SHAFT/AUXILIARY DRIVE GROUP		
ITEM	DESCRIPTION	QTY
D02J	KEY	1
D02S	KEY SQUARE	1

END CAP GROUP		
ITEM	DESCRIPTION	QTY
G10R	PLUG-END CAP	1
G11R	O-RING	1
G12R	RING-RETAINING	1
G02W	SEAL-LIP	1
G12W	RING-RETAINING	1

Unit Identification

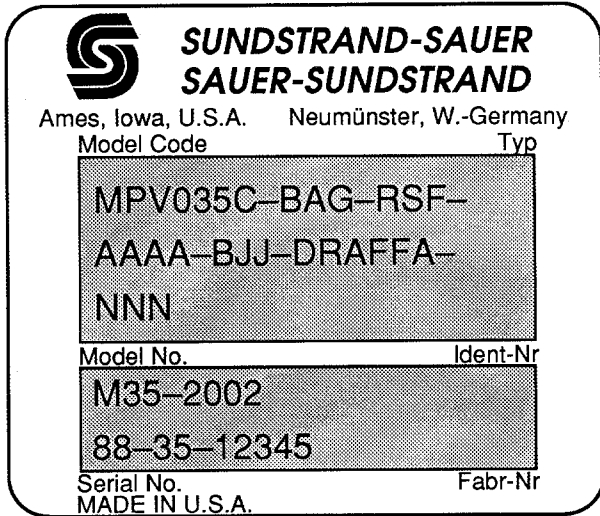

Name Plate

Each Series 40 pump and motor will have a name plate affixed to the housing. The name plate will include the following information:

Model Number

The Model Number is used by the factory in manufacturing. On repeat orders, a complete unit can be ordered by the Model Number. The Model Number is cross referenced to the specific Model Code for the unit.

Model Code

The Model Code completely defines the specific unit and must be used when ordering the complete unit for the first time or for ordering parts to service the product.

Serial Number

The Serial Number is used to identify the build date and the unit sequence in the build. The Serial Number is also used to identify the unit's warranty time period, and MUST be referenced when ordering service parts.

The first four (4) digits represent the Build Date Code. The first and second digit denotes the year of manufacture. The third and fourth digits denote the calendar week of manufacture. The fifth through ninth digits are sequential numbers used to identify a specific unit.

Name Plate

Bar Coding Tag

A Universal Bar Code, representing the Identification Number and the Serial Number, will also be affixed to production units so these items can be read electronically.

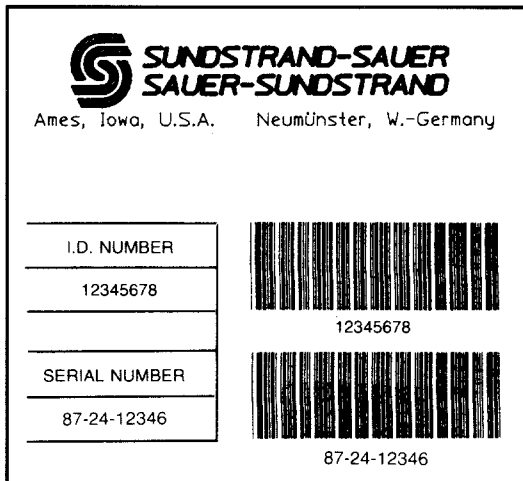

Bar Coding - Tag

Model Code

M35 Variable Displacement Pump -- PV

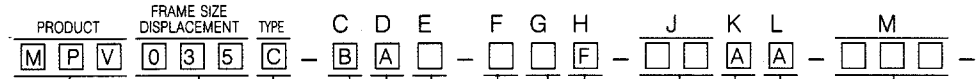

PRODUCT
MPV = MEDIUM DUTY, PUMP, VARIABLE

DISPLACEMENT
035 = 35 CC/REV (2.1 CU. IN./REV)

TYPE
C = CLOSED CIRCUIT

C: WASHPLATE GROUP
B = STANDARD

D: SEAL GROUP
A = SHAFT SEAL FOR DIRECT DISPL CONTROL

E: INPUT SHAFT
A = 13T 16/32P SPLINE
G = 15T 16/32P SPLINE
▶ N = 1 IN. DIA TAPERED, 1.5 IN./FT.
▶ Y = .875 IN. DIA STR KEY

F: ROTATION
R = CW
L = CCW

G: CHARGE PUMP DISPLACEMENT
▶ A = NONE
S = 11.8 CC/REV (.72 CU. IN./REV)

H: CHARGE PRESSURE RELIEF VALVE SETTING*
F = 7.0 BAR (100 PSI)

J: FILTRATION
AA = SUCTION
BA = REMOTE PRESSURE W/O BYPASS
▶ NN = NONE (W/O CHARGE PUMP)

K: DISPLACEMENT
A = FULL DISPLACEMENT

L: BYPASS VALVE
A = BYPASS VALVE

M: SYSTEM PRESSURE PROTECTION

TYPE	PROTECTION	
	PORT "A"	PORT "B"
A =	NONE	NONE
B =	PRESS. RELIEF	PRESS. RELIEF
C =	PRESS. RELIEF	NONE
D =	NONE	PRESS. RELIEF

SETTINGS (SELECT FOR PORT "A" & "B")*

- A = NONE
- M = 140 BAR (2030 PSI)
- B = 175 BAR (2540 PSI)
- C = 190 BAR (2755 PSI)
- D = 210 BAR (3045 PSI)
- E = 230 BAR (3335 PSI)
- F = 250 BAR (3625 PSI)
- G = 280 BAR (4060 PSI)
- H = 300 BAR (4350 PSI)
- J = 345 BAR (5000 PSI)

M35 Variable Displacement Pump -- PV

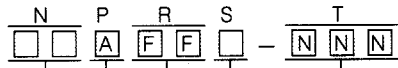

T: SPECIAL HARDWARE FEATURES
 NNN = NONE

S: AUXILIARY MOUNTING PAD
 A = SAE "A" 9T SPLINE
 D = SAE "A" 11T SPLINE
 B = SAE "B" 13T SPLINE
 C = NONE

R: CONTROL ORIFICE DIA
 SUPPLY DRAIN
 F = NONE F = NONE

P: HANDLE POSITION
 A = NOT APPLICABLE

N: CONTROL
 DR = DIRECT DISPLACEMENT CONTROL, RIGHT SIDE
 DL = DIRECT DISPLACEMENT CONTROL, LEFT SIDE

► = Non-Standard

*All pressure settings above are nominal set pressure at factory test conditions.
 Actual pressures will vary due to actual conditions.

M35 Tandem Pump -- PT

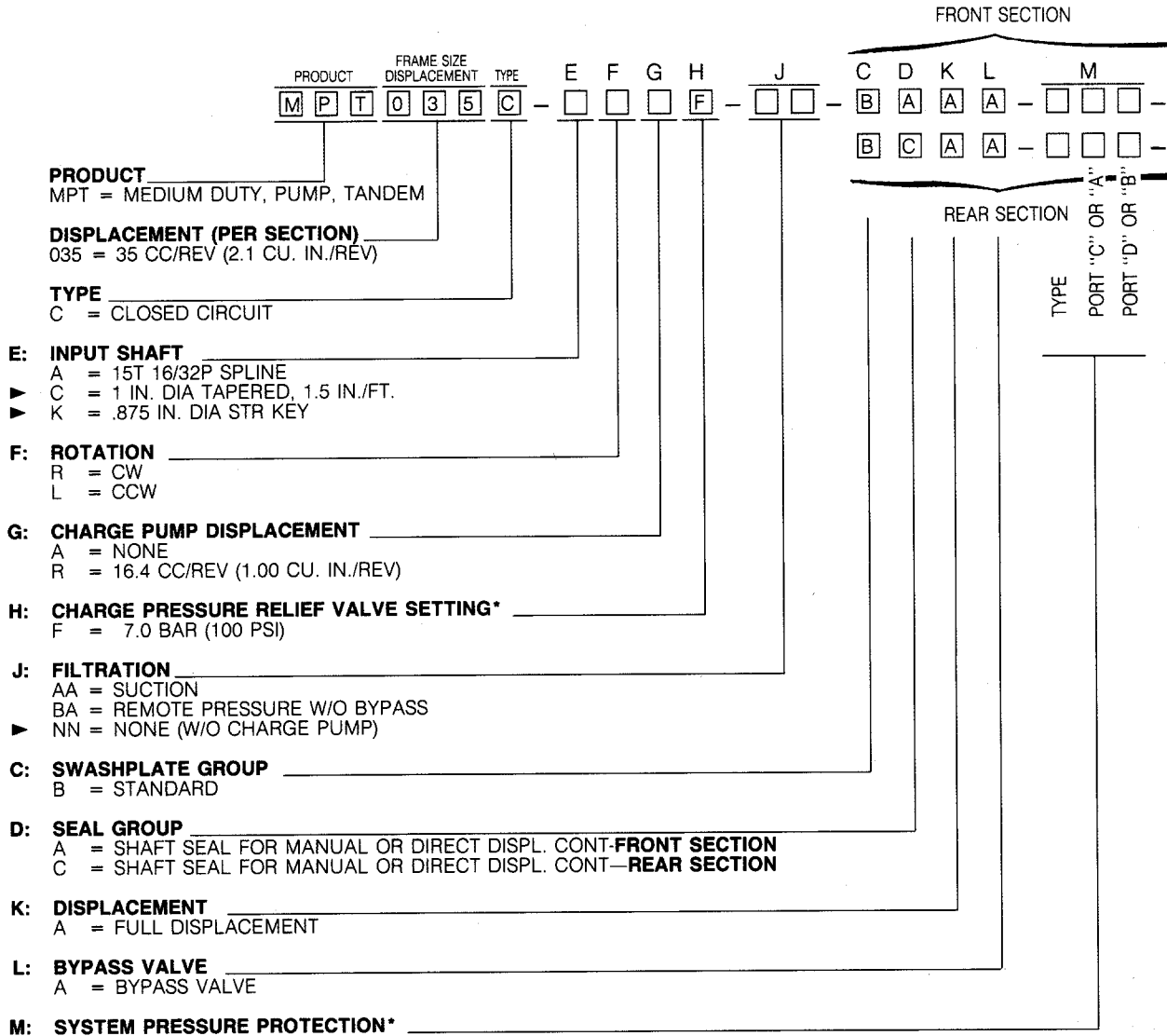

PROTECTION		
TYPE	PORT "A" or "C"	PORT "B" or "D"
A =	NONE	NONE
B =	PRESS. RELIEF	PRESS. RELIEF
C =	PRESS. RELIEF	NONE
D =	NONE	PRESS. RELIEF

SETTINGS (SELECT FOR PORT "A" & "B" AND "C" & "D")

- A = NONE
- M = 140 BAR (2030 PSI)
- B = 175 BAR (2540 PSI)
- C = 190 BAR (2755 PSI)
- D = 210 BAR (3045 PSI)
- E = 230 BAR (3335 PSI)
- F = 250 BAR (3625 PSI)
- G = 280 BAR (4060 PSI)
- H = 300 BAR (4350 PSI)
- J = 345 BAR (5000 PSI)

M35 Tandem Pump -- PT

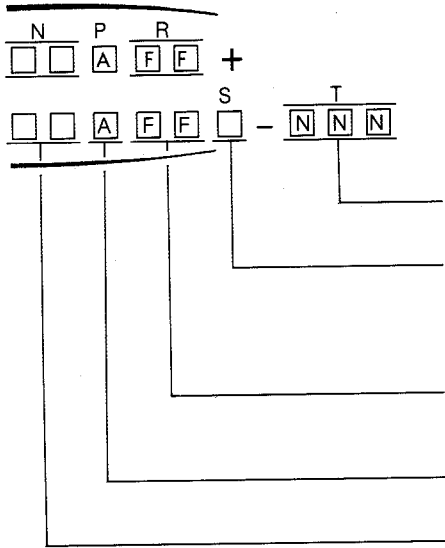

T: SPECIAL HARDWARE FEATURES
 NNN = NONE

S: AUXILIARY MOUNTING PAD
 A = SAE "A" 9T SPLINE
 D = SAE "A" 11T SPLINE
 B = SAE "B" 13T SPLINE
 C = NONE

R: CONTROL ORIFICE DIA
 SUPPLY DRAIN
 F = NONE F = NONE

P: HANDLE POSITION
 A = NOT APPLICABLE

N: CONTROL
 DR = DIRECT DISPLACEMENT CONTROL, RIGHT SIDE
 DL = DIRECT DISPLACEMENT CONTROL, LEFT SIDE

▶ = Non-Standard

*All pressure settings above are nominal set pressure at factory test conditions.
 Actual pressures will vary due to actual conditions.

M35 Fixed Displacement Motor -- MF

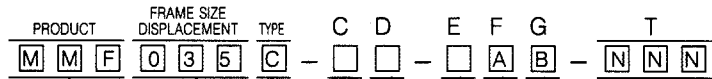

PRODUCT

MMF = MEDIUM DUTY, MOTOR, FIXED

DISPLACEMENT

035 = 35 CC/REV (2.1 CU. IN./REV)

TYPE

C = CLOSED CIRCUIT

C: SEAL GROUP

A = SHAFT SEAL

▶ B = SHAFT SEAL & SEAL FOR AUXILIARY DRIVE SHAFT

D: OUTPUT SHAFT/AUXILIARY DRIVE CONFIGURATION

A = 13T 16/32P SPLINE/NONE

F = 15T 16/32P SPLINE/NONE

▶ G = 15T 16/32P SPLINE/13T 16/32P SPLINE

▶ N = 1 IN. DIA TAPERED, 1.5 IN./FT./NONE

▶ S = .875 IN. DIA STR KEY/NONE

E: END CAP

A = RADIAL (SIDE) PORTS

B = AXIAL PORTS

▶ C = RADIAL (SIDE) PORTS W/AUXILIARY DRIVE

F: CYLINDER BLOCK GROUP

A = STANDARD BLOCK ASSEMBLY

G: BYPASS VALVE

B = NO BYPASS VALVE

T: SPECIAL HARDWARE FEATURES

NNN = NONE

▶ = Non-Standard

M35 Variable Displacement Motor -- MV

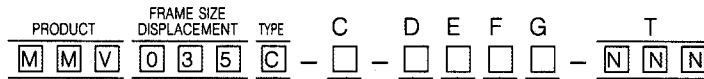

PRODUCT

MMV = MEDIUM DUTY, MOTOR, VARIABLE

DISPLACEMENT

035 = 35 CC/REV (2.1 CU. IN./REV)

TYPE

C = CLOSED CIRCUIT

C: SEAL GROUP

A = SHAFT SEAL

▶ B = SHAFT SEAL & SEAL FOR AUXILIARY DRIVE SHAFT

D: OUTPUT SHAFT/AUXILIARY DRIVE CONFIGURATION

A = 13T 16/32P SPLINE/NONE

E = 15T 16/32P SPLINE/NONE

▶ F = 15T 16/32P SPLINE/13T 16/32P

▶ J = 1 IN. DIA TAPERED, 1.5 IN./FT/NONE

▶ S = .875 IN. DIA STR KEY/NONE

E: MINIMUM DISPLACEMENT

A = 11 DEGREE SWASHPLATE ANGLE, 23.7 CC/REV (1.4) CU. IN./REV)

B = 7 DEGREE SWASHPLATE ANGLE, 15.0 CC/REV (.91) CU. IN./REV)

D = 6 DEGREE SWASHPLATE ANGLE, 12.8 CC/REV (.78) CU. IN./REV)

F = 9 DEGREE SWASHPLATE ANGLE, 19.3 CC/REV (1.18) CU. IN./REV)

J = 13 DEGREE SWASHPLATE ANGLE, 28.2 CC/REV (1.78) CU. IN./REV)

F: CONTROL FEATURES

CONTROL TRUNNION LOCATION

L = LEFT SIDE

R = RIGHT SIDE

G: HOUSING/END CAP CONFIGURATION

R = END CAP-RADIAL (TWIN) PORTS W/O BYPASS VALVE

▶ W = END CAP-RADIAL (TWIN) PORTS FOR AUXILIARY DRIVE SHAFT

T: SPECIAL HARDWARE FEATURES

NNN = NONE

▶ = Non-Standard

Notes

Description	Page
INTRODUCTION	1
GENERAL DESCRIPTION	2
Hydraulic Schematic.....	2
TRANSMISSION HYDRAULIC SUPPORT SYSTEM	3
Basic Closed Circuit.....	3
Case Drain and Heat Exchanger.....	3
Charge System and Inlet Filter.....	3
High Pressure Relief Valves.....	4
SAFETY PRECAUTIONS	4
PRODUCT SPECIFICATIONS	5
Technical Data - Variable Displacement Pump / Tandem Pump.....	5
Technical Data - Fixed Displacement Motor / Variable Displacement Motor.....	6
CONTROLS AND OPTIONS	7
Direct Displacement Control.....	7
Auxiliary Mounting Pads.....	7
Charge Pumps.....	7
Bypass Valve.....	7
START-UP AND MAINTENANCE	8
Fluids.....	8
Start-Up Procedure.....	8
Maintenance.....	8
TROUBLESHOOTING	9
Gauge Installation.....	9
Fault-Logic Diagrams.....	10
INSPECTIONS AND ADJUSTMENTS	11
Direct Displacement Control.....	11
Check/High Pressure Relief Valves.....	11
Pump Charge Relief Valve.....	11
Bypass Valve.....	11
MINOR REPAIR & REPLACEMENT	12
General.....	12
Shaft Seal.....	13
Trunnion Seals.....	14
Trunnion Cover.....	14
Check and High Pressure Relief Valves.....	15
Charge Pressure Relief Valve.....	15
Integral Charge Pump and Auxiliary Pump Mounting Pad (Variable Pump).....	16
Integral Charge Pump (Tandem Pump).....	18
Rear Shaft Cover (Tandem Pump).....	20
Auxiliary Pump Mounting Pad (Tandem Pump).....	20
Filtration and Charge Pump Options.....	21
GENERAL PARTS IDENTIFICATION	22
M35 Variable Displacement Pump - PV.....	22
M35 Tandem Pump - PT.....	24
M35 Fixed Displacement Motor - MF.....	26
M35 Variable Displacement Motor - MV.....	26
UNIT IDENTIFICATION	27
MODEL CODE	28
M35 Variable Displacement Pump - PV.....	28
M35 Tandem Pump - PT.....	30
M35 Fixed Displacement Motor - MF.....	32
M35 Variable Displacement Motor - MV.....	33
SUNDSTRAND - SAUER SERVICE CENTERS -- NORTH AMERICA	35