



Service Manual

Axial Piston Pumps

H1 - 069/078, 089/100, 115/130, 147/165



Revision history*Table of revisions*

Date	Changed	Rev
June 2014	Danfoss layout	BA

Contents

Introduction

Overview.....6
 Warranty.....6
 General instructions.....6
 Remove the Unit.....6
 Keep it Clean.....6
 Replace all O-rings and Gaskets.....6
 Secure the Unit.....6
 Safety Precautions.....7
 Unintended Machine Movement.....7
 Flammable Cleaning Solvents.....7
 Fluid Under Pressure.....7
 Personal Safety.....7
 Hazardous Material.....7
 Symbols used in Sauer-Danfoss literature.....8
 Design.....8
 The System Circuit.....9
 The Basic Closed Circuit.....9
 Case Drain and Heat Exchanger.....9

Operation

Pressure Limiter Valves..... 11
 High Pressure Relief Valve (HPRV) and Charge Check..... 11
 Bypass Function..... 12
 Charge Pressure Relief Valve..... 13
 Electrical Displacement Control (EDC)..... 13
 EDC Principle..... 13
 EDC Operation 13
 Manual OverRide (MOR)..... 14

Operating Parameters

Overview..... 15
 Input Speed..... 15
 System Pressure..... 15
 Charge Pressure..... 15
 Charge Inlet Pressure..... 16
 Case Pressure..... 16
 Temperature and Viscosity..... 16
 Temperature..... 16
 Viscosity..... 16

Technical Specifications

Overview..... 17
 General Specifications..... 17
 Physical Properties..... 17
 Operating Parameters 17
 Fluid Specifications..... 18

Fluid and Filter Maintenance

Fluid and Filter Recommendations..... 19
 Hazardous Material..... 19

Pressure Measurements

Port Locations and Gauge Installation..... 20

Specialized Tools

Overview..... 22
 Shaft Seal Installation Tool..... 22

Initial Startup Procedures

General23
 Start-Up Procedure.....23

Contents**Troubleshooting**

Overview.....	24
Safety Precautions.....	24
Electrical Troubleshooting.....	24
System Operating Hot.....	24
Integral Filter Bypass.....	25
Neutral Difficult or Impossible to Find.....	25
System Will Not Operate in Either Direction.....	25
System Noise or Vibration.....	26
Sluggish System Response.....	26
Transmission Operates Normally in One Direction Only.....	27

Adjustments

Pump Adjustment.....	28
Standard Procedures.....	28
Charge Pressure Relief Valve Adjustments.....	28
Pressure Limiter Adjustment.....	29
Engaging the Bypass Function.....	31
Displacement Limiter Adjustment.....	32
Control Neutral Adjustment.....	33
Mechanical Neutral Adjustment.....	35
Pump setup.....	35
Servo Adjustment.....	36

Minor Repair

Standard Procedures, Removing the Pump.....	38
Disassembly.....	38
Inspection.....	38
Reassembly.....	38
EDC Control.....	38
Removal.....	38
Inspection.....	38
Reassembly.....	39
Control Solenoids.....	40
Removal.....	40
Inspection.....	40
Reassembly.....	41
Automotive Control.....	41
Removal.....	41
Inspection.....	42
Assembly.....	43
Bearing and Shaft Replacement.....	43
Removal.....	43
Inspection.....	44
Reassembly.....	44
External Filter Replacement.....	45
Removal.....	45
Inspection.....	45
Reassembly.....	45
Filter Bypass Valve and Filter Bypass Switch.....	46
Removal.....	46
Inspection.....	46
Reassembly.....	46
Charge Pump.....	47
Charge pump removal (removable auxiliary pad/cover).....	47
Charge Pump Removal (integrated auxiliary pad).....	48
Inspection.....	49
Reassembly.....	49
High Pressure Relief Valves (HPRV).....	50
Removal.....	50

Contents

Inspection.....	50
Reassembly.....	50
Charge Pressure Relief Valve.....	51
Removal.....	51
Inspection.....	51
Reassembly.....	51
Pressure Limiter Valve Replacement.....	52
Removal.....	52
Inspection.....	52
Reassembly.....	52

Torque Chart

Fastener Size and Torques.....	54
Plug Size and Torques.....	54
Fasteners and Plugs.....	55

Introduction

Overview

This manual includes information on the installation, maintenance, and minor repair of H1 pumps. It includes a description of the unit and its individual components, troubleshooting information, and minor repair procedures.

Performing minor repairs requires the unit to be removed from the vehicle/machine. Thoroughly clean the unit before beginning maintenance or repair activities. Since dirt and contamination are the greatest enemies of any type of hydraulic equipment, follow cleanliness requirements strictly. This is especially important when changing the system filter and when removing hoses or plumbing.

A worldwide network of Danfoss Authorized Service Centers is available for major repairs. Danfoss trains and certifies Authorized Service Centers on a regular basis. You can locate your nearest Authorized Service Center using the distributor locator at www.Danfoss.com.

Warranty

Performing adjustments and minor repairs according to the procedures in this manual will not affect your warranty. Major repairs requiring the removal of a unit's center section, servo sleeves, or front flange voids the warranty unless a Danfoss Authorized Service Center performs them.

General instructions

Follow these general procedures when repairing H1 variable displacement closed circuit pumps.

Remove the Unit



Prior to performing repairs, remove the unit from the vehicle/machine. Chock the wheels on the vehicle or lock the mechanism to inhibit movement. Be aware that hydraulic fluid may be under high pressure and/or hot. Inspect the outside of the pump and fittings for damage. Cap hoses after removal to prevent contamination.

Keep it Clean



Cleanliness is a primary means of assuring satisfactory pump life on either new or repaired units. Clean the outside of the pump thoroughly before disassembly. Take care to avoid contamination of the system ports. Cleaning parts by using a clean solvent wash and air drying is usually adequate.

As with any precision equipment, you must keep all parts free of foreign material and chemicals. Protect all exposed sealing surfaces and open cavities from damage and foreign material. If left unattended, cover the pump with a protective layer of plastic.

Replace all O-rings and Gaskets



We recommend you replace all O-rings and seals during service. Lightly lubricate O-rings with clean petroleum jelly prior to assembly.

Secure the Unit



Introduction

For repair, place the unit in a stable position with the shaft pointing downward. It will be necessary to secure the pump while removing and torquing fasteners and components.

Safety Precautions

Always consider safety precautions before beginning a service procedure. Protect yourself and others from injury. Take the following general precautions whenever servicing a hydraulic system.

Unintended Machine Movement

 **Warning**

Unintended movement of the machine or mechanism may cause injury to the technician or bystanders. To protect against unintended movement, secure the machine or disable/disconnect the mechanism while servicing.

Flammable Cleaning Solvents

 **Warning**

Some cleaning solvents are flammable. To avoid possible fire, do not use cleaning solvents in an area where a source of ignition may be present.

Fluid Under Pressure

 **Warning**

Escaping hydraulic fluid under pressure can have sufficient force to penetrate your skin causing serious injury and/or infection. This fluid may also be hot enough to cause burns. Use caution when dealing with hydraulic fluid under pressure. Relieve pressure in the system before removing hoses, fittings, gauges, or components. Never use your hand or any other body part to check for leaks in a pressurized line. Seek medical attention immediately if you are cut by hydraulic fluid.

Personal Safety

 **Warning**

Protect yourself from injury. Use proper safety equipment, including safety glasses, at all times.

Hazardous Material

 **Warning**

Hydraulic fluid contains hazardous material. Avoid prolonged contact with hydraulic fluid. Always dispose of used hydraulic fluid according to state, and federal environmental regulations.

Introduction

Symbols used in Sauer-Danfoss literature

WARNING may result in injury	Tip, helpful suggestion
CAUTION may result in damage to product or property	Lubricate with hydraulic fluid
Reusable part	Apply grease / petroleum jelly
Non-reusable part, use a new part	Apply locking compound
Non-removable item	Inspect for wear or damage
Option - either part may exist	Clean area or part
Superseded - parts are not interchangeable	Be careful not to scratch or damage
Measurement required	Note correct orientation
Flatness specification	Mark orientation for reinstallation
Parallelism specification	Torque specification
External hex head	Press in - press fit
Internal hex head	Pull out with tool – press fit
Torx head	Cover splines with installation sleeve
O-ring boss port	Pressure measurement/gauge location or specification

The symbols above appear in the illustrations and text of this manual. They are intended to communicate helpful information at the point where it is most useful to the reader. In most instances, the appearance of the symbol itself denotes its meaning. The legend above defines each symbol and explains its purpose.

Design

Danfoss H1 closed circuit piston pumps convert input torque into hydraulic power. The input shaft transmits rotational force to the cylinder block. Bearings at the front and rear of the pump support the shaft. Splines connect the shaft to the cylinder block. A lip-seal at the front end of the pump prevents leakage where the shaft exits the pump housing. The spinning cylinder block contains nine reciprocating pistons. Each piston has a brass slipper connected at one end by a ball joint. The block spring, ball guide, and slipper retainer hold the slippers to the swashplate. The reciprocating movement of the pistons occurs as the slippers slide against the inclined swashplate during rotation. Via the valve plate, one half of the cylinder block is connected to low pressure and the other half to high pressure. As each piston cycles in and out of its bore, fluid is replenished by charge flow and displaced to the outlet thereby imparting hydraulic power into the system. A small amount of fluid is allowed to flow from the cylinder block/valve plate and slipper/swashplate interfaces for lubrication and cooling. Case drain ports return this fluid to the reservoir.

The angle of the swashplate controls the volume and direction of fluid displaced into the system. The servo piston controls the angle of the swashplate. The pump control, by varying the pressure at the servo

Introduction

piston, controls the piston's position. An electric signal to the control coils transmits the command from the operator to the pump. Mechanical feedback of the swashplate position to the control through the feedback pins allows for very precise displacement control and increases overall system stability. Non-feedback control options do not use the mechanical feedback link.

Cross section view

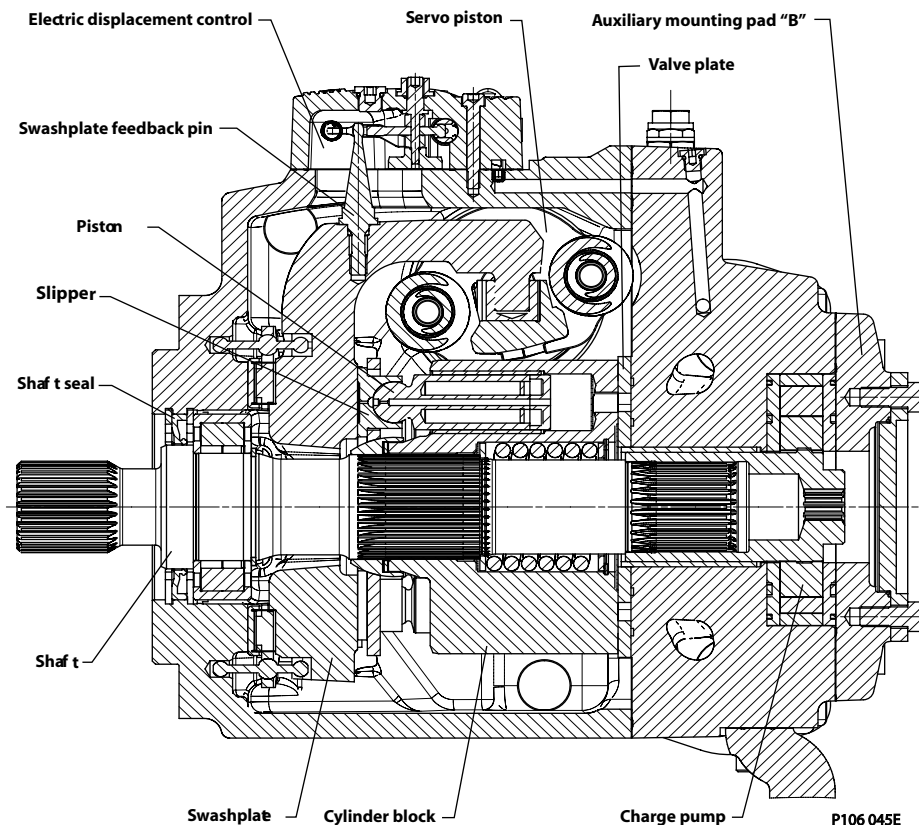

The System Circuit

The Basic Closed Circuit

Hydraulic lines connect the main ports of the pump to the main ports of the motor. Fluid flows in either direction from the pump to the motor and back. Either of the hydraulic lines can be under high pressure. In pumping mode the position of the pump swashplate determines which line is high pressure as well as the direction of fluid flow.

Case Drain and Heat Exchanger

The pump and motor require case drain lines to remove hot fluid from the system. The pump and motor drain from the topmost port to ensure the cases remain full of fluid. The motor case drain can connect to the lower drain port on the pump housing or it can tee into the case drain line upstream of the heat exchanger. A heat exchanger with bypass valve cools the case drain fluid before it returns to the reservoir.

Introduction

System Circuit Diagram

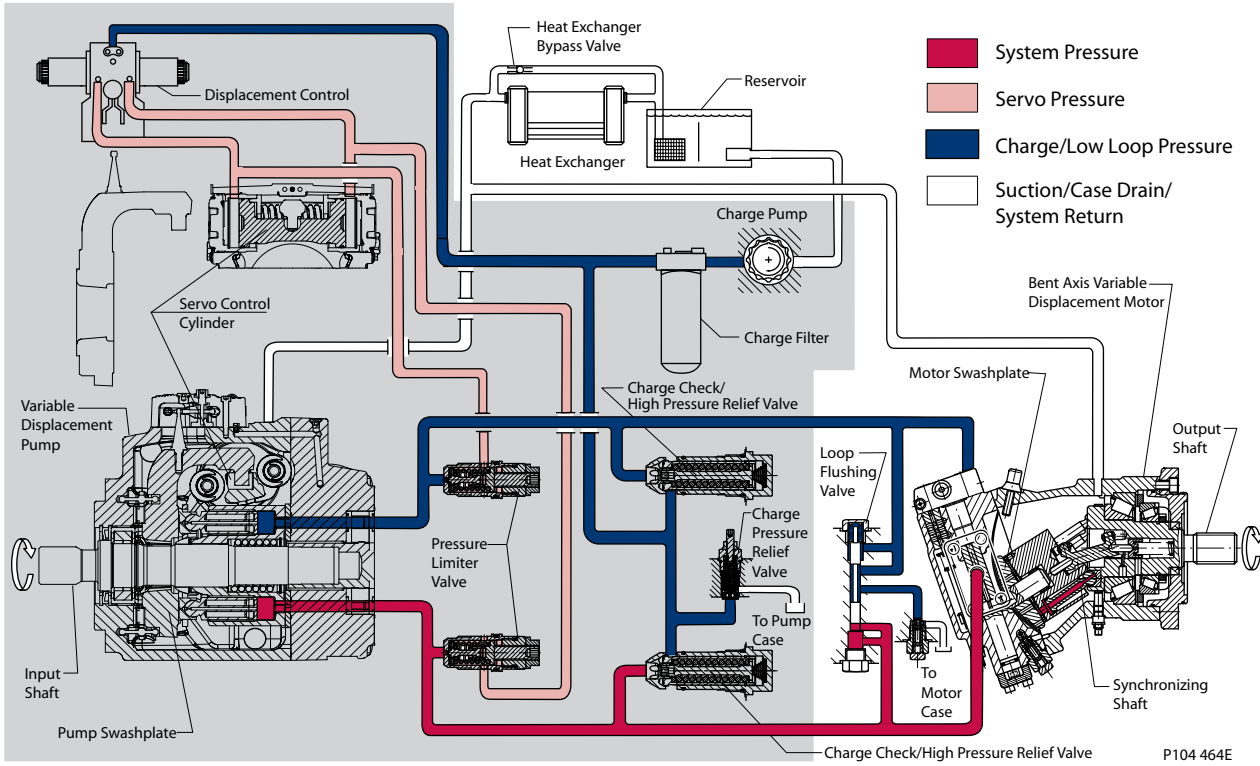

P104 464E

System Schematic

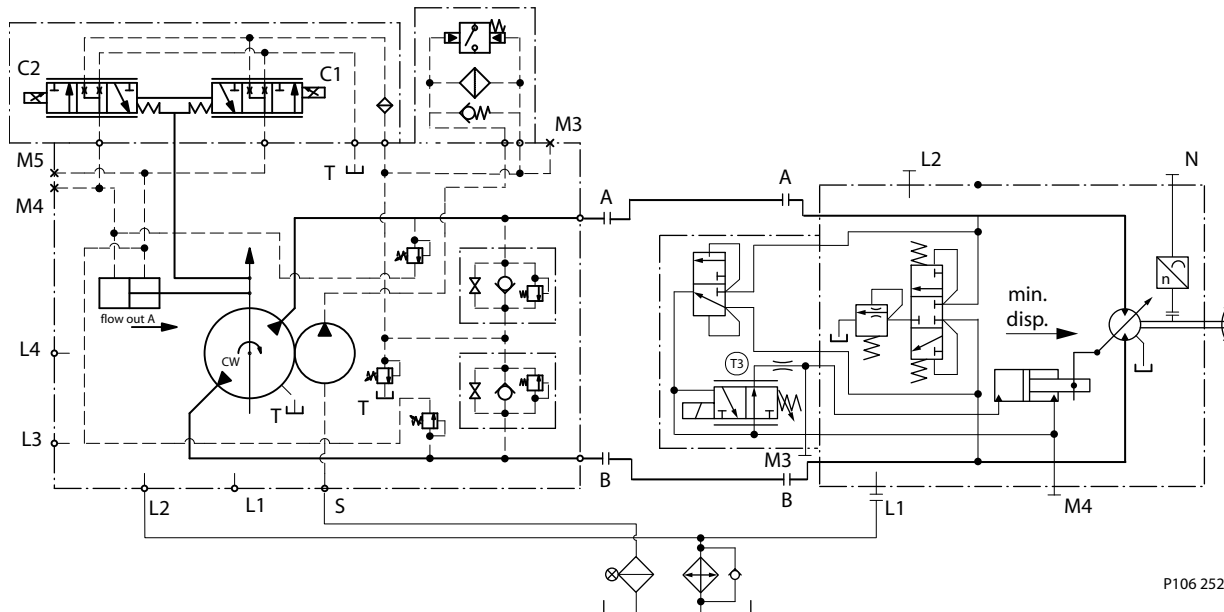

P106 252E

Above schematic shows the function of a hydrostatic transmission using an H1 axial piston variable displacement pump with electric displacement control (EDC) and a series 51-1 bent axis variable displacement motor with two-position control (T1).

Operation

Pressure Limiter Valves

Pressure limiter valves provide system pressure protection by compensating the pump swashplate position when the set pressure of the valve is reached. A pressure limiter is a non-dissipative (non heat generating) pressure regulating system.

Each side of the transmission loop (and each section of the tandem pump) has a dedicated pressure limiter valve that is set independently. Each system port may have a different pressure limiter setting.

The pressure limiter setting is the maximum differential pressure between the high and low loops. When the pressure limiter setting is reached, the valve ports oil to the lowpressure side of the servo piston. The change in pressure across the servo rapidly reduces pump displacement. Fluid flow from the valve continues until the resulting drop in pump displacement causes system pressure to fall below the pressure limiter setting.

An active pressure limiter destroys the pump to near neutral when the load is in a stalled condition. The pump swashplate moves in either direction necessary to regulate the system pressure, including increasing stroke when over-running or over-center.

The pressure limiter is optional on H1 pumps.

069/078/089/100 Single Pumps

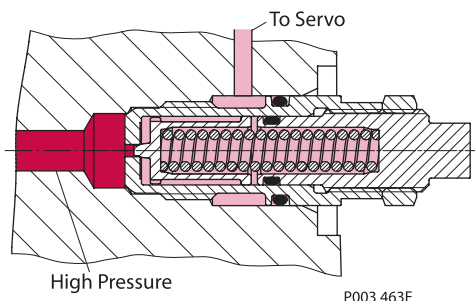

115/130/147/165 Single Pumps

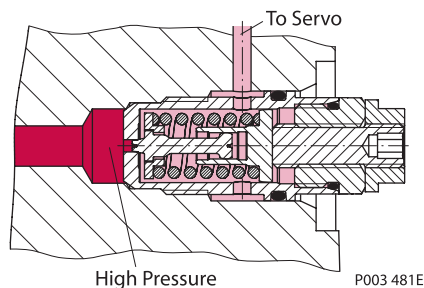

High Pressure Relief Valve (HPRV) and Charge Check

All H1 pumps have a combination high pressure relief and charge check valve. The high-pressure relief function is a dissipative (heat generating) pressure control valve for the purpose of limiting excessive system pressures. The charge check function replenishes the low-pressure side of the working loop with charge oil. Each side of the transmission loop has a dedicated non-adjustable, factory-set HPRV valve. When system pressure exceeds the factory setting of the valve, it passes oil from the high pressure system loop into the charge gallery and the low pressure system loop via the charge check.

The pump may have different pressure settings at each system port. When an HPRV valve is used in conjunction with a pressure limiter, the HPRV valve is always factory set above the setting of the pressure limiter. The system pressure shown in the order code for pumps with only HPRV is the HPRV setting. The system pressure shown in the order code for pumps with both pressure limiter and HPRV is the pressure limiter setting.

Operation

HPRVs are set at low flow condition. Any application or operating condition which leads to elevated HPRV flow will cause a pressure rise with flow above the valve setting. Consult factory for application.

High Pressure Relief and Charge Check Valve with Bypass Valve in charging mode

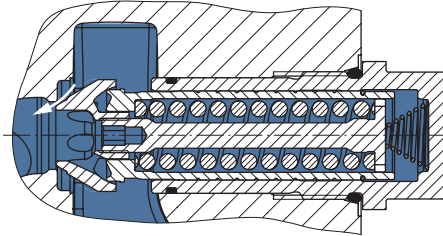

P003 269

High Pressure Relief and Charge Check Valve with Bypass Valve in relief mode

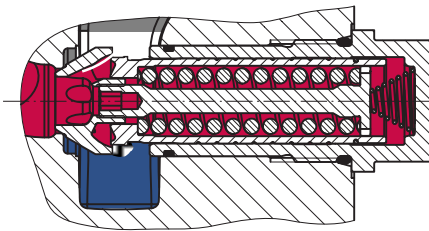

P003 268

Pressures marked on HPRV valve

Mark	Pressure bar [psi]
20	200 [2900]
25	250 [3626]
30	300 [4351]
35	350 [5076]
37	370 [5366]
40	400 [5801]
42	420 [6092]
45	450 [6527]
48	480 [6962]
51	510 [7397]

Bypass Function

The HPRV valve also provides a loop bypass function when each of the two HPRV hex plugs are mechanically backed out 3 full turns. Engaging the bypass function hydraulically connects both A & B sides of the working loop to the common charge gallery. The bypass function allows you to move a machine or load without rotating the pump shaft or prime mover.

! Caution

The HPRV valves are not tow valves. Damage to the pump and motor can occur when operating without charge flow. Limit vehicle/machine movement to no more than 20% of maximum speed and no longer than three minutes. Reseat the HPRV valves after vehicle/machine movement.

Operation

Charge Pressure Relief Valve

The charge pressure relief valve maintains charge pressure at a designated level above case pressure. The charge pressure relief valve is a direct acting poppet valve that opens and discharges fluid to the pump case when pressure exceeds a designated level. This level is nominally set with the pump running at 1800 min⁻¹ (rpm). For external charge flow, the CPRV is set with with a flow of 30 l/min [8 US gal/min]. In forward or reverse, charge pressure will be slightly lower than in neutral position. The model code of the pump specifies the charge relief setting.

Typically charge pressure increases from 1.2-1.5 bar per 10 l/min [17.4-21.8 psi per 2.64 US gal/min] case flow.

Charge Pressure Relief Valve

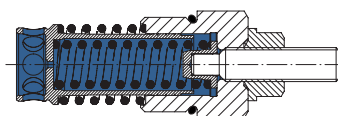

Electrical Displacement Control (EDC)

EDC Principle

The Electrical Displacement Control (EDC) consists of proportional solenoids on each side of a three-position, four-way porting spool. The proportional solenoid applies a force to the spool, which ports hydraulic fluid to either side of the servo piston. Differential pressure across the servo piston rotates the swashplate, changing the pump's displacement from full displacement in one direction to full displacement in the opposite direction.

EDC Operation

H1 EDC's are current driven controls requiring a Pulse Width Modulated (PWM) signal. Pulse width modulation allows more precise control of current to the solenoids. The PWM signal causes the solenoid pin to push against the porting spool, which pressurizes one end of the servo piston, while draining the other. Pressure differential across the servo piston moves the swashplate. A swashplate feedback link, opposing control links, and a linear spring provide swashplate position force feedback to the solenoid. The control system reaches equilibrium when the position of the swashplate spring feedback force exactly balances the input command solenoid force from the operator. As hydraulic pressures in the operating loop change with load, the control assembly and servo/swashplate system work constantly to maintain the commanded position of the swashplate.

The EDC incorporates a positive neutral dead-band as a result of the control spool porting, spring preload from the servo piston assembly, and the linear control spring. Once the neutral threshold current is reached, the swashplate position becomes directly proportional to the control current. To minimize the effect of the control neutral deadband, we recommended the transmission controller or operator input device incorporate a jump up current.

[The neutral position of the control spool does provide a positive preload pressure to each end of the servo piston assembly.](#)

When the control input signal is either lost or removed, or if there is a loss of charge pressure, the spring-loaded servo piston automatically returns the pump to neutral position.

The EDC is a displacement (flow) control. Pump swashplate position is proportional to the input command and therefore vehicle or load speed (excluding influence of efficiency), is dependent only on the prime mover speed or motor displacement.

Operation

EDC Schematic Diagram

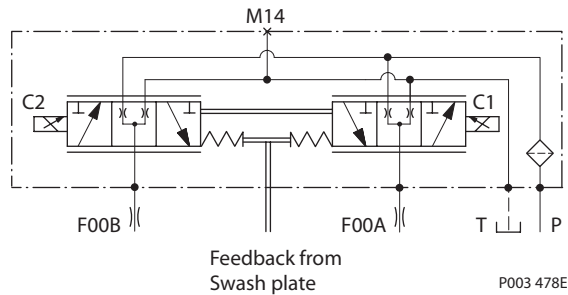

Manual OverRide (MOR)

All controls are available with a Manual OverRide (MOR) for temporary actuation of the control to aid in diagnosis. FNR controls always include MOR functionality.

Warning

Depressing the plunger causes the pump to go into stroke which will move the machine or mechanism. Ensure the vehicle or machine is in a safe condition (wheels off the ground or mechanism disconnected) before attempting to use the MOR feature.

An O-ring seals the MOR plunger. Initial actuation of the function requires additional force to overcome the O-ring resistance. A threshold force of 45 N is typically required at first actuation. Additional actuations typically require a threshold force of 12 N to move the MOR plunger. Force required to keep the pump at full stroke is typically 51 N. Do not expect proportional control of the pump using the MOR.

Refer to control flow table for the relationship of solenoid to direction of flow.

Control Solenoid

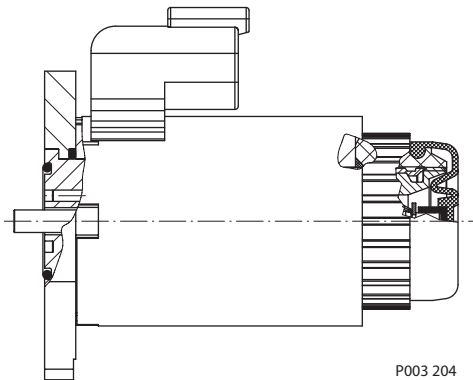

EDC Schematic Diagram Showing Manual OverRide

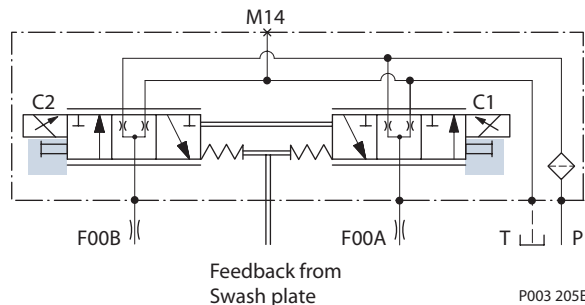

Operating Parameters

Overview

This section defines the operating parameters and limitations for H1 pumps with regard to input speeds and pressures. For actual parameters, refer to the operating parameters for each displacement.

Input Speed

Minimum speed is the lowest input speed recommended during engine idle condition. Operating below minimum speed limits the pump's ability to maintain adequate flow for lubrication and power transmission.

Rated speed is the highest input speed recommended at full power condition. Operating at or below this speed generally yields satisfactory product life.

Maximum speed is the highest operating speed permitted. Exceeding maximum speed reduces product life and can cause loss of hydrostatic power and braking capacity. Never exceed the maximum speed limit under any operating conditions.

When determining speed limits for a particular application see Sauer-Danfoss publication BLN-9884 Pressure and speed limits.

Warning

Unintended vehicle or machine movement hazard

Exceeding maximum speed may cause a loss of hydrostatic drive line power and braking capacity. You must provide a braking system, redundant to the hydrostatic transmission, sufficient to stop and hold the vehicle or machine in the event of hydrostatic drive power loss.

System Pressure

System pressure is the differential pressure between system ports A & B. It is the dominant operating variable affecting hydraulic unit life. High system pressure, which results from high load, reduces expected life. Hydraulic unit life depends on speed and normal operating—or weighted average—pressure that you can only determine from a duty cycle analysis.

Applied pressure is the chosen application pressure in the order code for the pump. This is the pressure at which the drive line generates maximum pull or torque in the application.

Rated pressure is the design pressure for the pump. Applications with applied pressures at or below this pressure should yield satisfactory unit life given proper component selection.

Maximum pressure (peak) is the highest intermittent pressure allowed under any circumstances. Applications with applied pressures between rated and maximum require factory approval with complete application, duty cycle, and life expectancy analysis.

All pressure limits are differential pressures referenced to low loop (charge) pressure. Subtract low loop pressure from gauge readings to compute the differential.

Charge Pressure

An internal charge relief valve regulates charge pressure. The internal charge pump supplies the control with pressure to operate the swashplate and to maintain a minimum pressure in the low side of the transmission loop.

Minimum charge pressure is the lowest pressure safe working conditions allow in the system loop. Minimum control pressure requirements are a function of speed, pressure, and swashplate angle, and may be higher than the minimum charge pressure shown in the technical specifications.

Maximum charge pressure is the highest charge pressure the charge relief adjustment allows, and which provides normal component life. You can use elevated charge pressure as a secondary means to reduce the swashplate response time.

Operating Parameters

The charge pressure setting listed in the order code is the set pressure of the charge relief valve with the pump in neutral, operating at 1800 min⁻¹ (rpm), and with a fluid viscosity of 32 mm²/sec [150 SUS]. The charge pressure setting is referenced to case pressure (the differential pressure above case pressure).

Charge Inlet Pressure

At normal operating temperature charge inlet pressure must not fall below *rated charge inlet pressure*.

Minimum charge inlet pressure is only allowed at cold start conditions. In some applications, you may need to warm up the fluid (start the prime mover without using the vehicle/machine functions) before moving the vehicle or operating the machine.

Case Pressure

Do not exceed rated case pressure under normal operating conditions. During cold start, keep case pressure below maximum intermittent case pressure. Size drain plumbing accordingly.

 **Caution**

Possible component damage or leakage

Operation with case pressure in excess of stated limits may damage seals, gaskets, and/or housings, causing external leakage. This condition may also affect performance since charge and system pressure are referenced to case pressure.

Temperature and Viscosity

Temperature

High temperature limits apply at the hottest point in the transmission loop, which is normally the motor case drain. Ensure the system generally runs at or below the rated temperature. The maximum intermittent temperature is based on material properties: Never exceed it.

Cold oil will generally not affect the durability of the transmission components, but it may affect the ability of oil to flow and transmit power: therefore ensure temperatures remain 16 °C [30 °F] above the pour point of the hydraulic fluid. Minimum temperature relates to the physical properties of component materials.

Size heat exchangers to keep the fluid within these limits. Sauer-Danfoss recommends testing to verify that these temperature limits are not exceeded.

Viscosity

For maximum efficiency and bearing life, ensure the fluid viscosity remains in the recommended range. Minimum viscosity should be encountered only during brief occasions of maximum ambient temperature and severe duty cycle operation. Maximum viscosity should be encountered only at cold start.

Technical Specifications

Overview

Specifications and operating parameters for pumps are given here for reference.

General Specifications

Design	Axial piston pump of cradle swashplate design with variable displacement
Direction of rotation	Clockwise, counterclockwise
Pipe connections	Main pressure ports: SAE straight thread O-ring boss Remaining ports: SAE straight thread O-ring boss
Recommended installation position	Pump installation recommended with control position on the top or side. Consult Sauer-Danfoss for non conformance to these guidelines. The housing must always be filled with hydraulic fluid. Rear case drain recommended
Auxiliary cavity pressure	Will be equal to pump case pressure of rear housing. Please verify mating pump shaft seal capability.

Physical Properties

Feature	Unit	Frame size								
		069	078	089	100	115	130	147	165	
Displacement	cm ³ [in ³]	69 [4.21]	78 [4.76]	89 [4.76]	100 [4.76]	115.2 [7.03]	130.0 [7.93]	147 [8.97]	165 [10.07]	
Oil volume	liter [US gal]	2.0 [0.5]				3.0 [0.8]				
Mounting flange		SAE flange, size C (SAE J 744) mounting pad				SAE flange, size D (SAE J 744) mounting pad				
Auxiliary mounting		SAE A, SAE B, SAE B-B, SAE C				SAE A, SAE B, SAE B-B, SAE C, SAE D				
Shafts		Splined: 21-teeth 16/32, 23-teeth 16/32, 14-teeth 12/24				Splined: 27-teeth 16/32, 13-teeth 8/16				
Suction port		1.625-12UN-2B [1 5/8-12UN-2B]								
Main port configuration		Ø25.4 - 450 bar split flange boss per ISO 6162 M12x1.75				Ø31.5 - 450 bar split flange boss per ISO 6162 M12x1.75				
Case drain ports L1, L3 (SAE O-ring boss).		0.875-12UNF-2B [7/8-12UNF-2B]				1.0625-12UNF-2B [1 1/16-12UNF-2B]				
Case drain ports L2, L4 (SAE O-ring boss) preferred usage		1.0625-12UNF-2B [1 1/16-12UNF-2B]				1.3175-12UNF-2B [1 5/16-12UNF-2B]				
Other ports		SAE O-ring boss. See installation drawings.								
Customer interface threads		Metric fastener								

Operating Parameters

Feature		Unit	Frame size							
			069	078	089	100	115	130	147	165
Input speed	Minimum	min ⁻¹ (rpm)	500							
	Minimum for full performance		1200							
	Rated		3500				3200		3000	
	Maximum		4000				3400		3100	

Technical Specifications

Feature		Unit	Frame size							
			069	078	089	100	115	130	147	165
System pressure	Rated	bar [psi]	400 [5800]				450 [6525]	420 [6090]	450 [6525]	400 [5800]
	Maximum		450 [6525]				480 [6960]	450 [6525]	480 [7000]	450 [6525]
	Minimum low loop		10 [150]							
Charge Pressure	Minimum	bar [psi]	10 [150]						16 [232]	
	Maximum		35 [508]							
Control Pressure	Minimum (at corner for EDC and FNR)	bar [psi]	17 [247]							
	Minimum (at corner for NFPE)		20 [290]					17 [247]		
	Maximum		40 [580]							
Charge pump inlet pressure	Rated	bar (absolute) [in Hg vacuum]	0.7 [9]							
	Minimum (cold start)		0.2 [24]							
	Maximum	bar [psi]	4.0 [58]							
Case pressure	Rated	bar [psi]	3.0 [40]							
	Maximum		5.0 [75]							

Fluid Specifications

Feature		Unit	Value
Viscosity	Minimum	mm ² /sec [SUS]	7 [49]
	Recommended Range		12-80 [66-370]
	Maximum		1600 [7500]
Temperature Range	Minimum	OC [OF]	-40 [-40]
	Rated		104 [220]
	Maximum intermittent		115 [240]
Filtration (recommended minimum)	Cleanliness per ISO 4460		22/18/13
	Efficiency (charge pressure filtration)	b-ratio	b ₁₅₋₂₀ = 75 (b ₁₀ ≥ 10)
	Efficiency (suction and return line filtration)		b ₃₅₋₄₅ = 75 (b ₁₀ ≥ 2)
	Recommended inlet screen mesh size	mm	100 - 125

Ratings and data are based on operation with premium petroleum-based hydraulic fluids containing oxidation, rust, and foam inhibitors.

Fluid and Filter Maintenance

Fluid and Filter Recommendations

To ensure optimum life, perform regular maintenance of the fluid and filter. Contaminated fluid is the main cause of unit failure. Take care to maintain fluid cleanliness when servicing.

Check the reservoir daily for proper fluid level, the presence of water, and rancid fluid odor. Fluid contaminated by water may appear cloudy or milky or free water may settle in the bottom of the reservoir. Rancid odor indicates the fluid has been exposed to excessive heat. Change the fluid and correct the problem immediately if these conditions occur.

Inspect vehicle for leaks daily. Change the fluid and filter per the vehicle/machine manufacturer's recommendations or at intervals shown in the table. We recommend first fluid change at 500 hours.

High temperatures and pressures will result in accelerated fluid aging. More frequent fluid changes may be required.

Change the fluid more frequently if it becomes contaminated with foreign matter (dirt, water, grease, etc.) or if the fluid is subjected to temperature levels greater than the recommended maximum. Dispose of used hydraulic fluid properly. Never reuse hydraulic fluid.

Change filters with the fluid or when the filter indicator shows it's necessary. Replace all fluid lost during filter change.

For detailed filtration information, see Danfoss publication **520L0463** Fluids and Filtration. For information on biodegradable fluids see Danfoss publication **520L0465** Biodegradable Hydraulic Fluids.

Fluid and Filter Change Interval

Reservoir type	Max oil change interval
Sealed	2000 hours
Breather	500 hours

Hazardous Material

Warning

Hydraulic fluid contains hazardous material. Avoid contact with hydraulic fluid. Always dispose of used hydraulic fluid according to state and federal environmental regulations.

Pressure Measurements
Port Locations and Gauge Installation

The following table and drawing show the port locations and gauge sizes needed. When testing system pressures, calibrate pressure gauges frequently to ensure accuracy. Use snubbers to protect gauges.

Port Information

Port identifier	Port size	Wrench size	Reading	Gauge size, bar [psi]	Displacement
L1, L3	7/8-14 UNF 2B	3/8 internal hex	Case drain	10 [100]	069/078
L2, L4	1 1/16-12 UNF 2B	9/16 internal hex	Case drain	10 [100]	069/078/089/100
L1, L3	1 1/16-12 UNF 2B	9/16 internal hex	Case drain	10 [100]	089/100/115/ 130/147/165
L2, L4	1 5/16-12 UNF 2B	5/8 internal hex	Case drain	10 [100]	115/130/147/165
MA, MB	9/16-18 UNF	1/4 internal hex	System pressure	600 [10,000]	115/130/147/165
M3	9/16-18 UNF 2B	1/4 internal hex	Charge pressure- after filter	50 [1000]	115/130/147/165
M4, M5	7/16-20 UNF 2B	3/16 internal hex	Servo pressure	50 [1000]	115/130/147/165
M6	9/16-18 UNF 2B	1/4 internal hex	Charge pressure - pre integrated filter	50 [1000]	115/130/147/165

Pressure Measurements

Port locations

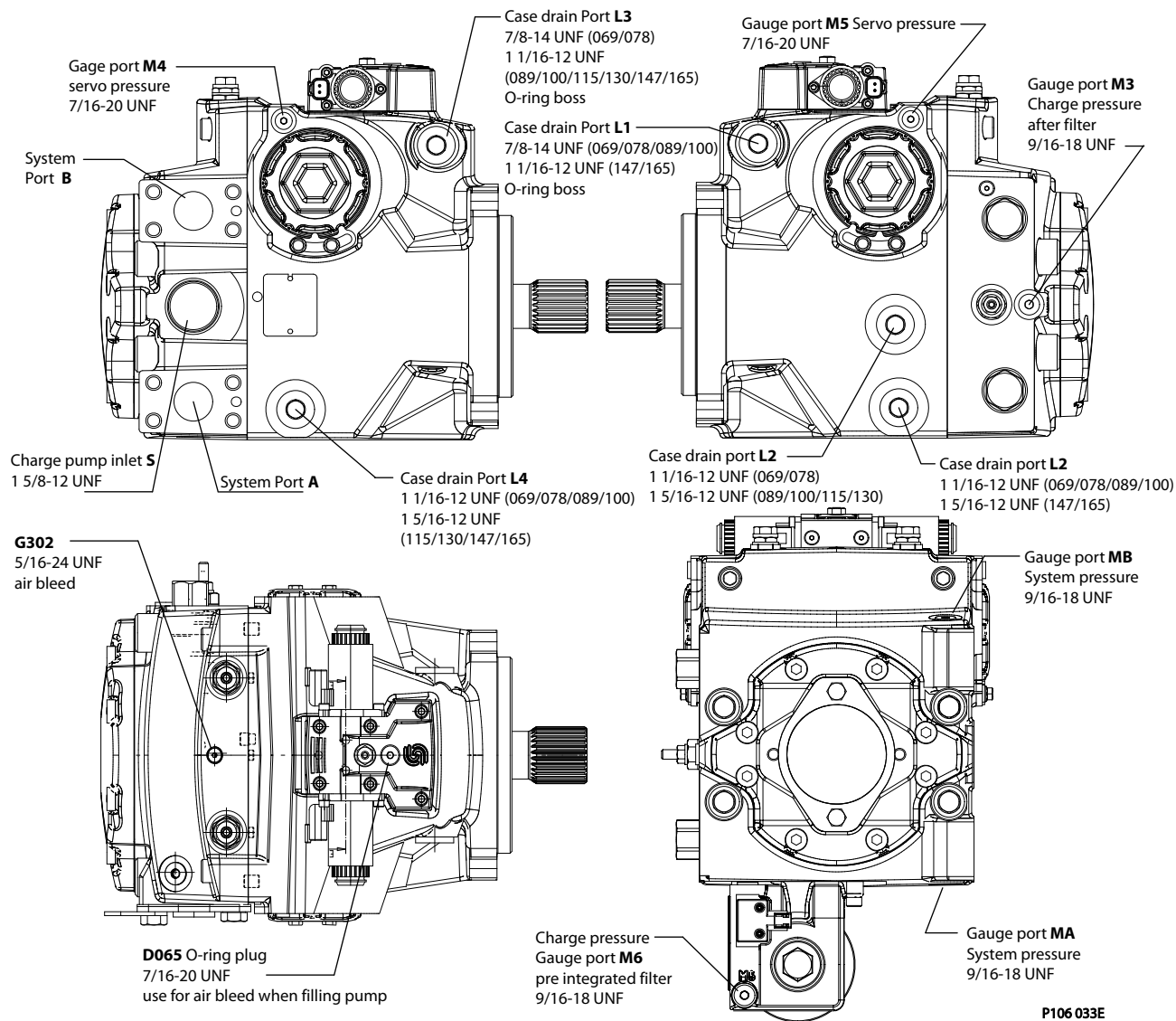

P106 033E

Specialized Tools

Overview

You can perform the service procedures described in this manual using common mechanic's hand tools. This section details any specialized tools helpful to service H1 pumps.

Shaft Seal Installation Tool

Shaft Seal Installation Tool Drawing

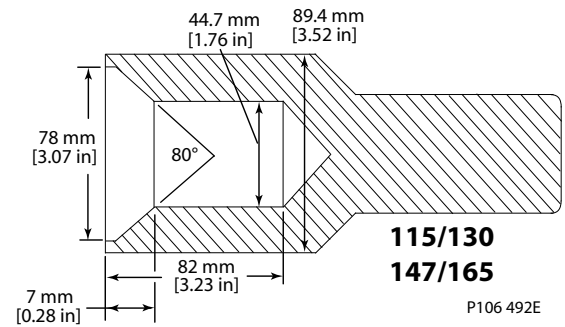
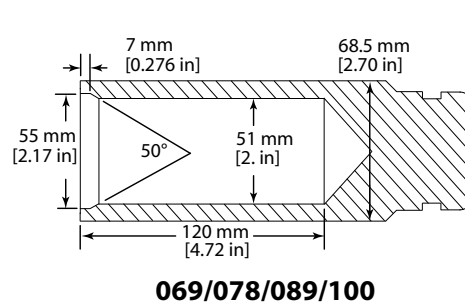

Initial Startup Procedures

General

Follow this procedure when starting-up a new pump installation or when restarting an installation in which the pump has been removed and re-installed on a machine. Ensure pump has been thoroughly tested on a test stand before installing on a machine.

⚠ Warning

Unintended movement of the machine or mechanism may cause injury to the technician or bystanders. To protect against unintended movement, secure the machine or disable/disconnect the mechanism while servicing.

Prior to installing the pump, inspect for damage that may have occurred during shipping.

Start-Up Procedure

1. Ensure that the machine hydraulic oil and system components (reservoir, hoses, valves, fittings, and heat exchanger) are clean and free of any foreign material.
2. Install new system filter element(s) if necessary. Check that inlet line fittings are properly tightened and there are no air leaks.
3. Install the pump. Install a 50 bar [1000 psi] gauge in the charge pressure gauge port M
4. Fill the housing by adding filtered oil in the upper case drain port. If the control is installed on top, open the construction plug in the top of the control to assist in air bleed.
5. Fill the reservoir with hydraulic fluid of the recommended type and viscosity. Use a 10-micron filler filter. Fill inlet line from reservoir to pump.
6. Disconnect the pump from all control input signals.
7. Close construction plug removed in Step 4.

⚠ Caution

After start-up the fluid level in the reservoir may drop due to system components filling. Damage to hydraulic components may occur if the fluid supply runs out. Ensure reservoir remains full of fluid during start-up.

Air entrapment in oil under high pressure may damage hydraulic components. Check carefully for inlet line leaks.

Do not run at maximum pressure until system is free of air and fluid has been thoroughly filtered.

8. Use a common method to disable the engine to prevent it from starting. Crank the starter for several seconds. Do not to exceed the engine manufacturer's recommendation. Wait 30 seconds and then crank the engine a second time as stated above. This operation helps remove air from the system lines. Refill the reservoir to recommended full oil level.
9. When the gauge begins to register charge pressure, enable and start engine. Let the engine run for a minimum of 30 seconds at low idle to allow the air to work itself out of the system. Check for leaks at all line connections and listen for cavitation. Check for proper fluid level in reservoir.
10. When adequate charge pressure is established (as shown in model code), increase engine speed to normal operating rpm to further purge residual air from the system.
11. Shut off engine. Connect pump control signal. Start engine, checking to be certain pump remains in neutral. Run engine at normal operating speed and carefully check for forward and reverse control operation.
12. Continue to cycle between forward and reverse for at least five minutes to bleed all air and flush system contaminants out of loop.

Normal charge pressure fluctuation may occur during forward and reverse operation.

13. Check that the reservoir is full. Remove charge pressure gauge. The pump is now ready for operation.

Troubleshooting

Overview

This section provides troubleshooting steps to follow if you are having problems with your machine. Follow the steps as listed until you solve the problem. Some of the troubleshooting items are system specific. We reference another section in this manual if more information is available. Always observe the safety precautions listed in the Introduction section and precautions related to your specific equipment.

Safety Precautions

! Caution

High inlet vacuum causes cavitation which can damage internal pump components.

! Warning

Escaping hydraulic fluid under pressure can have sufficient force to penetrate your skin causing serious injury and/or infection. Relieve pressure in the system before removing hoses, fittings, gauges, or components.

Unintended movement of the machine or mechanism may cause injury to the technician or bystanders. To protect against unintended movement, secure the machine or disable/disconnect the mechanism while servicing.

! Caution

Contamination can damage internal components and void the manufacturer's warranty. Take precautions to ensure system cleanliness when removing and reinstalling system lines

! Warning

Hydraulic fluid contains hazardous material. Avoid contact with hydraulic fluid. Always dispose of used hydraulic fluid according to state, and federal environmental regulations.

Electrical Troubleshooting

Item	Description	Action
Control operates pump in one direction only.	Control coil failure	Measure resistance at coil pins. Resistance should be 14.20 ohms (24V) or 3.66 ohms (12V) at 20°C [70°F]. Replace coil
No pump function	No power to controller	Restore power to controller.
Erratic pump function	Electrical connection to pump is bad.	Disconnect connection, check wires, reconnect wires.
Filter bypass indicator switch	Filter bypass indicator switch may be bad.	Check/replace filter switch. Add gauge to filter bypass port to verify proper fluid flow and verify switch operation by measuring resistance: open resistance ≥ 510 ohms, closed resistance ≤ 122 ohms

If available, use manual override to check proper pump operation and verify electrical problem.

System Operating Hot

Item	Description	Action
Oil level in reservoir.	Insufficient hydraulic fluid will not meet cooling demands of system.	Fill reservoir to proper level.

Troubleshooting

Item	Description	Action
Heat exchanger.	Heat exchanger is not sufficiently cooling the system.	Check air flow and input air temperature for heat exchanger. Clean, repair or replace heat exchanger.
Charge pressure.	Low charge pressure will overwork system.	Measure charge pressure. Inspect and adjust or replace charge relief valve. Inspect charge pump. Repair or replace charge pump.
Charge pump inlet vacuum.	High inlet vacuum will overwork system. A dirty filter will increase the inlet vacuum. Inadequate line size will restrict flow.	Check charge inlet vacuum. If high, inspect inlet filter and replace as necessary. Check for adequate line size, length or other restrictions.
System relief pressure settings	If the system relief valves are worn, contaminated, or valve settings are too low, the relief valves will be overworked.	Verify settings of pressure limiters and high pressure relief valves and adjust or replace valves as necessary.
System pressure.	Frequent or long term operation over system relief setting will create heat in system.	Measure system pressure. If pressure is too high, reduce loads.

Integral Filter Bypass

Item	Description	Action
Filter bypass activated	Filter is plugged causing fluid to bypass filter.	Replace filter. Check that bypass switch indicates proper operation after filter is replaced.
Filter bypass indicator switch	Filter bypass indicator switch is indicating wrong bypass situation.	Check/replace switch. open >= 510 ohms closed <= 122 ohms

Neutral Difficult or Impossible to Find

Item	Description	Action
Input to pump control	Input to control module is operating improperly.	Disconnect input and check to see if pump comes back to neutral. If Yes, input fault, replace/repair external controller. If No, go to next step.
Neutral	Neutral set improperly	Shunt servo gauge ports (M4 and M5) together with external hose and see if pump comes back to neutral. If Yes: Control neutral improperly set. If neutral is still impossible to set, balance the swashplate (see Mechanical Neutral Adjustment). If you still cannot set neutral, replace the control.

System Will Not Operate in Either Direction

Item	Description	Action
Oil level in reservoir.	Insufficient hydraulic fluid to supply system loop.	Fill reservoir to proper level.
Pump control orifices	Control orifices are blocked.	Clean control orifices.
Pump control screens	Control screens are blocked.	Replace control screens. Refer to 520L0874 H1 069/078/147/165 Repair instructions for screen locations. Only a Sauer-Danfoss Authorized Service Center may remove the unit's endcap without voiding the warranty.
Bypass function open	If bypass function is open, the system loop will be depressurized.	Close bypass valves. Replace high pressure relief valve if defective.
Low charge pressure with pump in neutral	Low charge pressure insufficient to recharge system loop.	Measure charge pressure with the pump in neutral. If pressure is low, go to Pump charge relief valve.

Troubleshooting

Item	Description	Action
Low charge pressure with pump in stroke	Low charge pressure resulting from elevated loop leakage. Insufficient control pressure to hold pump in stroke.	Deadhead the pump to isolate it from the motor. With pump in partial stroke and engaged for only a few seconds, check pump charge pressure. Low charge pressure indicates a malfunctioning pump. Continue to next step. Good charge pressure indicates a malfunctioning motor or other system component. Check motor charge relief operation (if present).
Pump charge relief valve	A pump charge relief valve that is leaky, contaminated, or set too low will depressurize the system.	Adjust or replace pump charge relief valve as necessary.
Charge pump inlet filter	A clogged filter will under supply system loop.	Inspect filter and replace if necessary.
Charge pump	A malfunctioning charge pump will provide insufficient charge flow.	Repair or replace the charge pump.
System pressure	Low system pressure does not provide enough power to move load.	Measure system pressure. Continue to next step.
High pressure relief or pressure limiter valves	Defective high pressure relief or pressure limiter valves cause system pressure to be low.	Repair or replace high pressure relief or pressure limiter valves.
Input to control	Input operating improperly	Repair/replace control.

System Noise or Vibration

Item	Description	Action
Reservoir oil level	Low oil level leads to cavitation.	Fill reservoir.
Aeration of the oil/pump inlet vacuum	Air in system decreases efficiency of units and controls. Excessive noise, foaming oil, and hot oil all indicate air in system.	Find location where air is entering into the system and repair. Check that inlet line is not restricted and is proper size.
Cold oil	If oil is cold, it may be too viscous for proper function and pump cavitates.	Allow the oil to warm up to its normal operating temperature with engine at idle speed.
Pump inlet vacuum	High inlet vacuum causes noise/cavitation.	Check that inlet line is not restricted and is of proper size. Check filter and bypass switch.
Shaft couplings	A loose shaft coupling will cause excessive noise.	Replace loose shaft coupling..
Shaft alignment	Misaligned shafts create noise.	Align shafts.
Charge/system relief valves	Unusual noise may indicate sticking valves and possible contamination.	Clean/replace valves and test pump.

Sluggish System Response

Item	Description	Action
Oil level in reservoir	Low oil level causes sluggish response.	Fill reservoir.
High pressure relief valves/ pressure limiter settings	Incorrect pressure settings affects system reaction time.	Adjust or replace high pressure relief valves.
Low prime mover speed	Low engine speed reduces system performance.	Adjust engine speed.
Charge pressure	Incorrect pressure affects system performance.	Measure and adjust charge pressure relief or replace charge pump.
Air in system	Air in system produces sluggish system response.	Fill tank to proper level. Cycle system slowly for several minutes to remove air from system.
Contaminated control orifices	Control orifices are plugged.	Clean control orifices.

Troubleshooting

Item	Description	Action
Contaminated control screens	EDC supply screen is plugged.	Replace control screens. Refer to 520L0874 H1 069/078/147/165 Repair instructions for screen locations. Only a Sauer-Danfoss Authorized Service Center may remove the unit's endcap without voiding the warranty.
Pump inlet vacuum	Inlet vacuum is too high resulting in reduced system pressure.	Measure charge inlet vacuum. Inspect line for proper sizing. Replace filter. Confirm proper bypass operation.

Transmission Operates Normally in One Direction Only

Item	Description	Action
Input to pump control.	Input to control module is operating improperly.	Check control input and repair or replace as necessary.
Control orifices	Control orifice(s) are blocked.	Clean control orifices.
Control screens	Control screen(s) are blocked.	Replace control screens. Refer to 520L0874 H1 069/078/147/165 Repair instructions for screen locations. Only a Sauer-Danfoss Authorized Service Center may remove the unit's endcap without voiding the warranty.
Exchange system pressure limiters	Exchanging the pressure limiter valves will show if the problem is related to the valve function.	If the problem changes direction, replace the valve that does not operate correctly.
Exchange high pressure relief valves	Exchanging the high pressure relief valves will show if the problem is related to the valve function.	If the problem changes direction, replace the valve that does not operate correctly.
Servo pressure low or decaying	Damaged servo seals may prevent servo piston from stroking the pump.	Check for torn/missing servo seals. Replace and retest. Refer to 520L0874 H1 069/078/147/165 Repair instructions for seal locations. Only a Sauer-Danfoss Authorized Service Center may remove the servo piston without voiding the warranty.
Bypass function open	Open bypass will cause one or both directions to be inoperative.	Close bypass function.

Adjustments

Pump Adjustment

This section offers instruction on inspection and adjustment of pump components. Read through the entire topic before beginning a service activity. Refer to Pressure measurements, page 22, for location of gauge ports and suggested gauge size.

Standard Procedures

! Caution

Contamination can damage internal components and void your warranty. Take precautions to ensure system cleanliness when removing and reinstalling system lines

1. With the prime mover off, thoroughly clean the outside of the pump.
2. If removing the pump, tag each hydraulic line. When you disconnect hydraulic lines, cap them and plug each open port to prevent contamination.
3. Ensure the surrounding area is clean and free of contaminants like dirt and grime.
4. Inspect the system for contamination.
5. Check the hydraulic fluid for signs of contamination: oil discoloration, foam in the oil, sludge, or metal particles.
6. If there are signs of contamination in the hydraulic fluid, replace all filters and drain the hydraulic system. Flush the lines and refill the reservoir with the correct filtered hydraulic fluid.
7. Before re-installing the pump, test for leaks.

Charge Pressure Relief Valve Adjustments

This procedure explains how to check and adjust the charge pressure relief valve.

1. Install a 50 bar [1000 psi] pressure gauge in charge pressure gauge port M3. Install a 10 bar [100 psi] gauge at case drain port L1, L2, L3, or L4. Operate the system with the pump in neutral (zero displacement) when measuring charge pressure.
2. The table shows the acceptable pump charge pressure range for some nominal charge relief valve settings (refer to model code located on serial number plate). These pressures assume 1800 min-1 (rpm) pump speed and a reservoir temperature of 50°C [120°F], and are referenced to case pressure.

Charge Pressure Adjustment

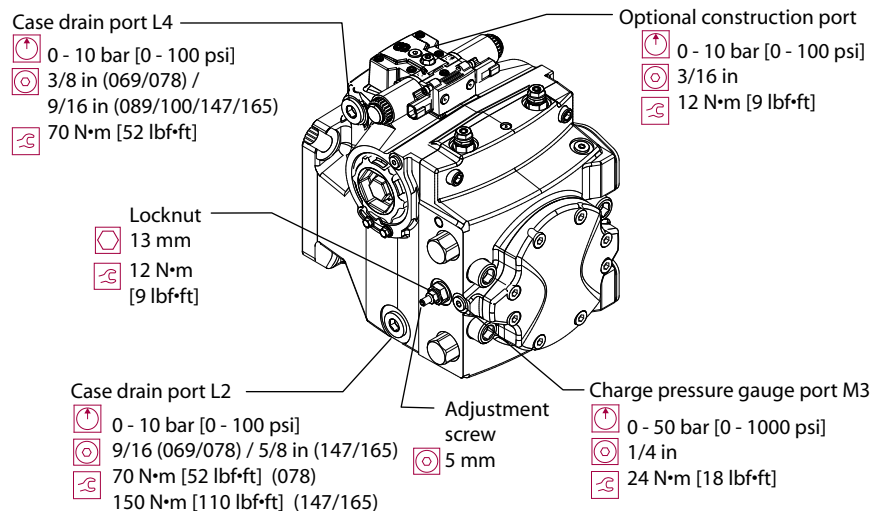

P104 466E

Adjustments

Listed pressures assume a pump speed of 1800 min⁻¹ (rpm). At higher pump speeds (with higher charge flows) the charge pressure will rise over the rated setting.

Depending on the pressure rating, the charge pressure relief valve may have one or two springs.

Charge Pressure Ranges

Model code	Actual charge pressure*
20	20 bar [290 psi] ± 1.5 bar [21.8 psi]
24	24 bar [348 psi] ± 1.5 bar [21.8 psi]
26	26 bar [377 psi] ± 1.5 bar [21.8 psi]
30	30 bar [435 psi] ± 1.5 bar [21.8 psi]

* This is the actual charge pressure port gauge reading minus the case pressure port gauge reading. Factory set at 1800 min⁻¹ (rpm) with a reservoir temperature of 50° C [120° F].

- Loosen the locknut and turn the adjusting screw clockwise to increase the setting; counterclockwise to decrease it. The table gives approximate adjustment per turn.

Number of springs	Change per turn
1 Spring	consult factory
2 Springs	3.9 bar [56.6 psi]

- While holding the adjusting screw, torque locknut to 12 N•m [9 lbf•ft].
- When you achieve the desired charge pressure setting, remove the gauges and plug the ports.

Pressure Limiter Adjustment

Lock motor output shaft to adjust the pressure limiter setting. Lock the vehicle's brakes or rigidly fix the work function so it cannot rotate.

- Install 600 bar [10,000 psi] pressure gauges in the high pressure gauge ports (MA and MB). Install a 50 bar [1000 psi] pressure gauge in the charge pressure gauge port (M3).

Ensure charge pressure is properly set before checking pressure limiter.

If you change pressure limiter settings, you must also change the HPRV valve to maintain proper PL function. Refer to table on next page for corresponding settings.

Subtract charge pressure from system pressure to get correct system pressure.

Adjustments

Pressure Limiter Adjustment

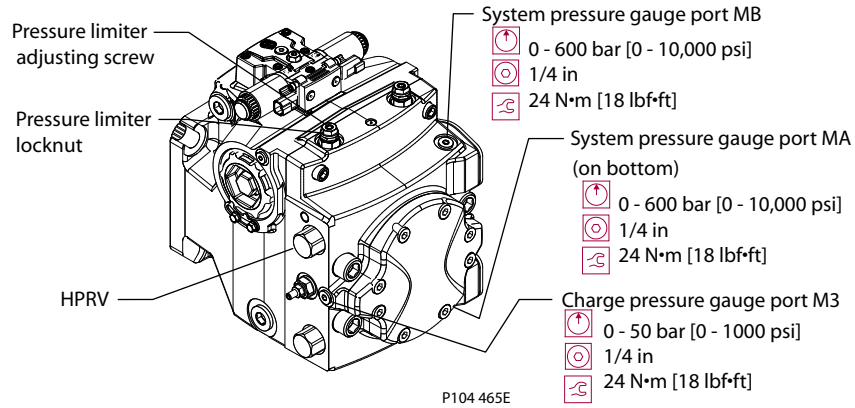

115/130/147/165	Fastener	Torque N•m [lbf•ft]
L010 Adjusting screw 5 mm internal hex	L010	N/A
L024 Locking nut 17 mm	L024	20 [15]
L028 Plug (special) 19 mm	L028	68 [50]
L012 Cartridge 22 mm	L012	70 [52]

069/078 Pressure limiter	Fastener	Torque N•m [lbf•ft]
L028 Adjusting screw 8 mm internal hex	L028	N/A
L024 Locking nut 14 mm	L024	20 [15]
L012 Cartridge 22 mm	L012	30 [22]

P106 351E

Pressure Limiter Valve Adjustment

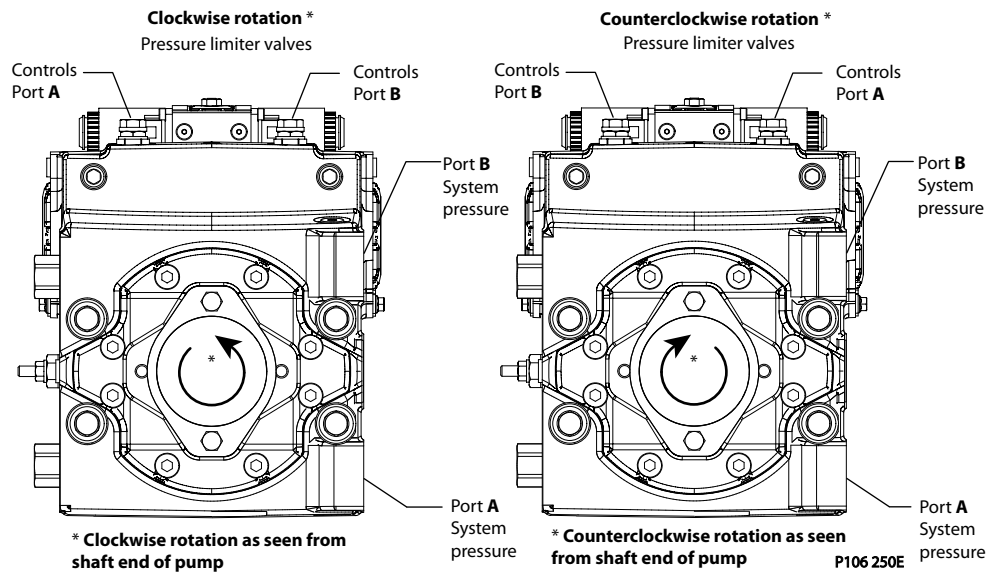

Endcaps are different for clockwise and counterclockwise rotation.

2. Start the prime mover and operate at normal speed.
3. Use a 17mm wrench to loosen the locking nut (L024).
4. Activate the control input until pressure in the high side of the system loop stops rising. This pressure is the PL setting.
5. Return the pump to neutral and adjust the PL setting using an internal hex wrench. Wrench size is in the diagram on the previous page. Turn the adjusting screw clockwise to increase the PL setting, counterclockwise to decrease it. The adjustment is very sensitive. Change per turn is approximately 150 bar [2176 psi].

Change per turn is 150 bar/rev [2176 psi/rev].

Adjustments

The model code on the serial plate gives the factory setting of the PL (Pressure Limiter). The PL setting is referenced to charge pressure. Subtract charge pressure from system pressure gauge readings to compute the effective PL setting.

6. Repeat steps four and five until you reach the desired PL setting. After adjustment, torque the locknut (L024) to 20 N•m [15 lbf•ft]. Do not over torque.
7. Shut down the prime mover. Remove gauges and replace plugs.

Pressure Limiter Settings

Pressure limiter setting	HPRV setting
150	200
180	230
200	250
230	280
250	300
280	330
300	350
330	380
350	400
380	420
400	450
410	
420	
430	480
440	
450	
460	510
470	
480	

Engaging the Bypass Function

Use this procedure to bypass the pump to allow moving the vehicle/machine short distances when you cannot start the prime mover.

 **Caution**

It is possible to damage the drive motor(s) by operating in bypass mode without charge pressure. Move the vehicle/machine at a speed not more than 20% of maximum for a duration not exceeding 3 minutes.

1. To open the HPRVs (L150), rotate three revolutions counterclockwise. Do not rotate more than 3 revolutions, leakage will result.
2. To close the HPRVs, rotate them clockwise until seated. See table above for torque values.
3. If machine is towable with HPRVs opened three turns and if wheels are locked (not towable) with HPRV valves closed, bypass function is working correctly.

Adjustments

Engaging the Bypass Function

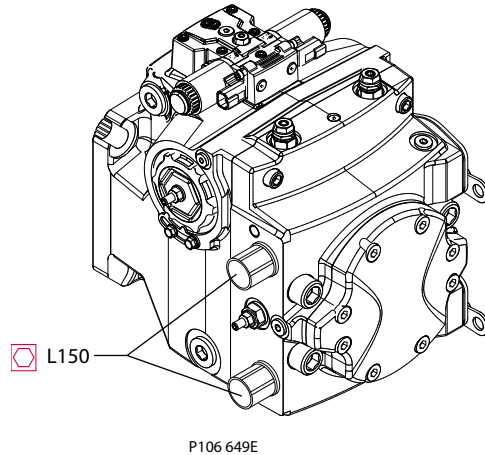

HPRV Wrench Size and Torque Values

Displacement	Wrench size and torque
069/078	22 mm - 70 N•m [52 lbf-ft]
115/130/147/165	30 mm - 110 N•m [81 lbf-ft]

Displacement Limiter Adjustment

If your pump has displacement limiters, you will find them on either servo cover. You can limit forward and reverse displacement independently.

Displacement limiters are not pre-set by the factory. We install them as far as possible without contacting the servo piston. Limiting displacement requires clockwise adjustment of the limiting screw.

⚠ Caution

Before adjusting the displacement limiter, mark the position of the servo cylinder. Be sure the servo cylinder does not turn when setting the displacement limiter locknut.

1. Loosen the lockingnut.
2. Rotate the adjusting screw to achieve the desired maximum displacement. Set the adjusting screw against the servo piston by feel before counting turns. Refer to the table below for change per turn. Clockwise rotation decreases displacement, counterclockwise rotation increases it. Adjustment is possible from zero to maximum.
3. After establishing the desired maximum displacement setting, hold the adjusting screw while torquing the locknut to the value in the table below.
4. Test operation of the vehicle/machine to verify proper maximum speed of vehicle/work function.

Adjustments

Displacement Limiter Adjustment

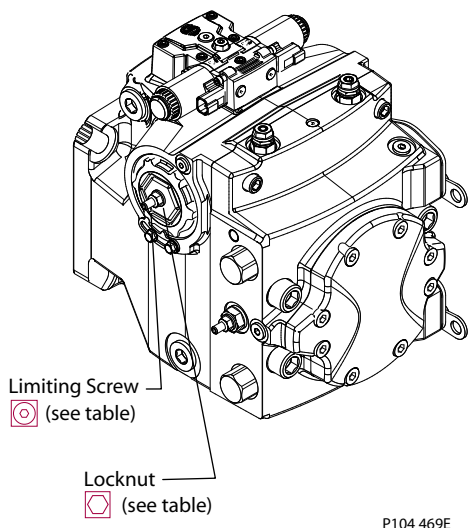

Displacement Limiter Adjustment Data

Displacement	Locknut wrench size and torque	Adjusting screw wrench size	Approximate displacement change per revolution of adjusting screw
069	13 mm - 24 N•m [18 lbf-ft]	4 mm	6.0 cm ³ /turn [0.366 in ³ /turn]
078	13 mm - 24 N•m [18 lbf-ft]	4 mm	7.4 cm ³ /turn [0.452 in ³ /turn]
089	17 mm - 48 N•m [35 lbf-ft]	5 mm	9.3 cm ³ /turn [0.57 in ³ /turn]
100	17 mm - 48 N•m [35 lbf-ft]	5 mm	10.7 cm ³ /turn [0.65 in ³ /turn]
115	22 mm - 80 N•m [59 lbf-ft]	6 mm	10.8 cm ³ /turn [0.66 in ³ /turn]
130	22 mm - 80 N•m [59 lbf-ft]	6 mm	12.2 cm ³ /turn [0.745 in ³ /turn]
147	22 mm - 80 N•m [59 lbf-ft]	6 mm	12.4 cm ³ /turn [0.757 in ³ /turn]
165	22 mm - 80 N•m [59 lbf-ft]	6 mm	13.9 cm ³ /turn [0.848 in ³ /turn]

Control Neutral Adjustment

All functions of the Electric Displacement Control (EDC), are preset at the factory. If necessary, adjust the pump to neutral with the pump running on a test stand or on the vehicle/machine with the prime mover operating. If adjustment fails to give satisfactory results, you may need to replace the control or coils. See Minor repair for details.

Warning

Unintended movement of the machine or mechanism may cause injury to the technician or bystanders. To protect against unintended movement, secure the machine or disable/disconnect the mechanism while servicing.

1. Install a 50 bar [1000 psi] gauge in each of the two servo gauge ports (M4 and M5). Disconnect the external control input (electrical connections) from the control. Start the prime mover and operate at normal speed.
2. Use a 4mm internal hex wrench to hold the neutral adjusting screw (D015) stationary while loosening the locknut (D060) with a 13mm wrench.
3. Observe pressure gauges. If necessary, turn adjusting screw (D015) to reduce pressure differential.

EDC adjustment is very sensitive. Be sure to hold the hex wrench steady while loosening the locknut. Total adjustment is less than 120 degrees.

Adjustments

Control Adjustment

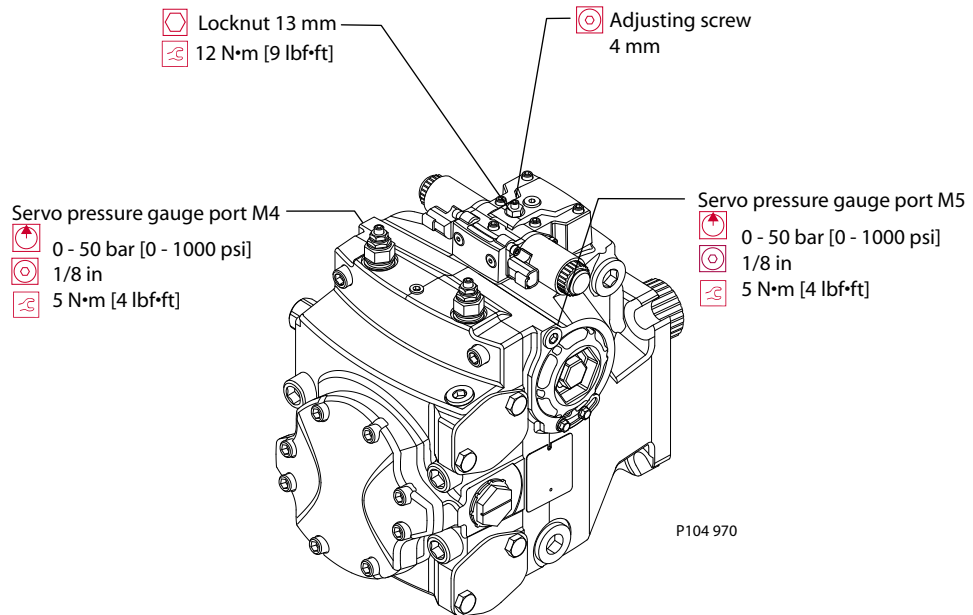

4. Rotate the neutral adjusting screw (D015) clockwise until the pressure increases on the gauge. Note the angular position of the wrench. Then rotate the neutral adjusting screw counterclockwise until the pressure increases by an equal amount on the other gauge. Again note the angular position of the wrench.
5. Rotate the neutral adjusting screw clockwise half the distance between the wrench positions noted above. The gauges should read the same pressure, indicating that the control is in its neutral position.
6. Hold the neutral adjusting screw stationary and tighten the locknut (D060). Torque to 12 N•m [9 lbf•ft]. Do not over torque the nut.
7. When the neutral position is set, stop the prime mover, remove the gauges, and install the gauge port plugs. Reconnect the external control input.

A small pressure differential of 1.5 bar [22 psi] or less is acceptable. Zero differential is usually not possible.

Adjustments

Neutral Adjustment (EDC) (bottom view)

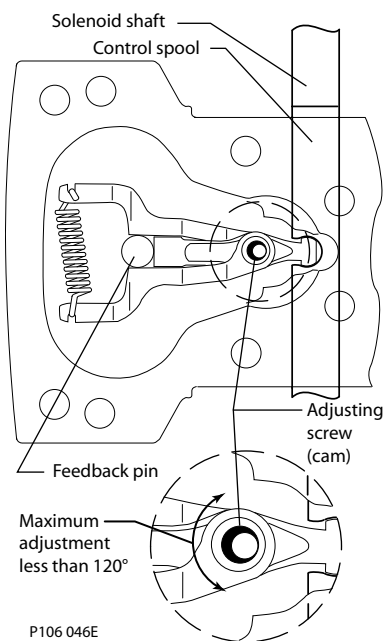

Illustration shows how cam on adjusting pin rotates to adjust for neutral position after pump is re-installed.

Mechanical Neutral Adjustment

Mechanical neutral is set with the pump running at 1800 min⁻¹ (rpm). To set neutral, you must stroke the pump in each direction. You can do this with a small movement of the eccentric screw on EDC controls, however non-feedback controls (NFPE/FNR) lack this mechanism. To stroke a pump with non-feedback control, you must provide a 100 Hz PWM signal to the control solenoids. Refer to the H1 Pumps Technical Information manual 11009999 for signal specifications. If you perform this adjustment with the pump installed in a vehicle or machine, safely elevate the wheels or disconnect the mechanism to allow safe operation during adjustment.

This procedure details setting neutral for the pump. Alternate M4/M5 and MA/MB to zero out forward and reverse directions of the unit Refer to the drawing on the next page to identify all ports. The control solenoids C1 and C2 are marked on the control.

While performing this adjustment, you will monitor the following pressures.

- Servo pressure at M4 and M5
- System pressure at MA and MB
- Pressure differential between M4 and M5 (optional)
- Pressure differential between A and B (optional)

Refer to [Pressure measurement](#) and the illustration on the next page for gauge port locations and information.

Pump setup

1. Attach a 50 bar [1000 psi] gauge to each servo pressure port M4 and M5.
2. Attach a 600 bar [10 000 psi] gauge to each system pressure port (MA and MB).
3. Remove servo cylinder locking screws (E350) and plates (E300) from both sides of the pump.
4. Disconnect the control solenoids from the vehicle wiring harness.

Adjustments

5. If using a PWM signal to set mechanical neutral, connect the control solenoids C1 and C2 to the signal source. Ensure the source supplies no current to the solenoids until required in the following procedure.

The figure below shows the locations of system and gage ports you use when adjusting the servo neutral position.

System Pressure Gage Port Locations

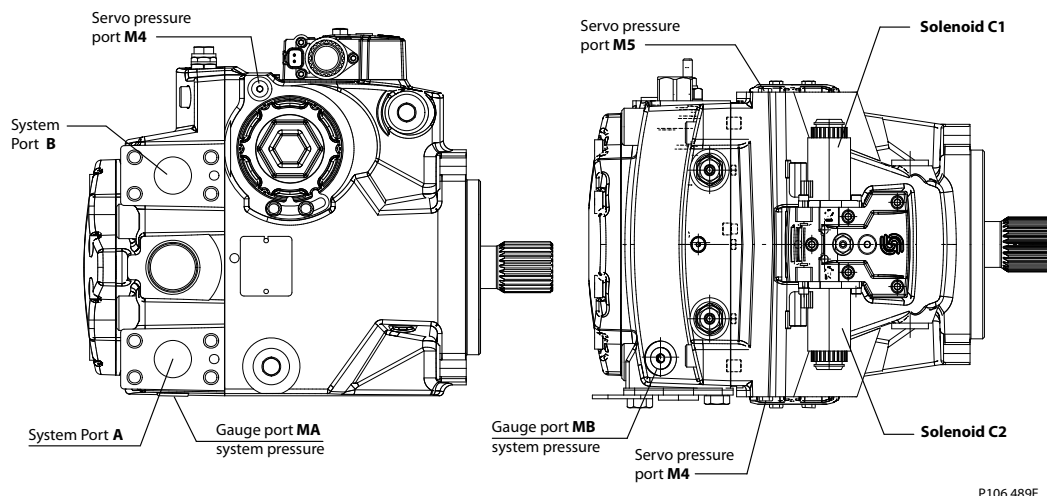

Servo Adjustment

1. Run prime mover at 1800 min⁻¹(rpm).
2. If using a PWM signal, ensure the signal is off. Check the servo pressure gauges. Ensure the differential between M4 and M5 is less than 1.5 bar [22 psi].
3. Using a 3/4 in hex deep socket, unthread both servo cylinders 2-3 turns. This step ensures the servo cylinders have no contact with the servo piston.
4. Stroke the pump by turning the control eccentric screw (or supplying current to solenoid C1) until the servo pressure at port M4 is 1 to 2 bar [14– 29 psi] greater than at port M5 and the system pressure gauges indicate displacement. Pressure should be greater at port MA for clockwise rotation, or MB for counterclockwise rotation. This also indicates the servo piston is in contact with the servo cylinder on side M5.
5. Slowly thread the servo cylinder on the M5 side in until the system pressure differential starts to decrease. Maintain servo pressure differential between 1-2 bar [14-29 psi] during this step. Continue turning the servo cylinder in until the system pressure differential (between ports MA/MB) is less than 1.5 bar [22 psi]. This procedure sets the servo and swashplate to mechanical neutral on the M5 side.
6. To complete setting neutral, repeat steps 1-5 but stroke the pump in the opposite direction by turning the eccentric screw in the opposite direction, or by supplying current to solenoid C2. Reverse gauge locations (M4 for M5, MB for MA) from those stated above since the pump is now stroking the other direction.
7. Remove all gauges and replace gauge port plugs. You can find wrench sizes and plug torques in the Plug Size and Torque Chart.

Adjustments

Servo Adjustment

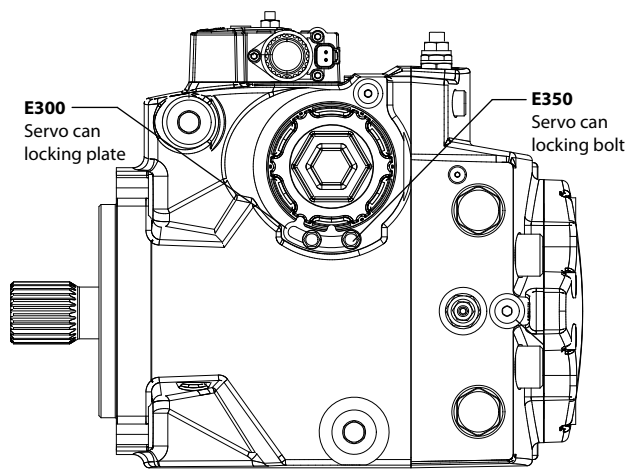

P106 490E

Minor Repair

Standard Procedures, Removing the Pump

Before working on the pump, thoroughly clean the outside. If the pump has an auxiliary pump attached, remove both pumps as a single unit. Tag and cap all hydraulic lines as they are disconnected, and plug all open ports to ensure that dirt and contamination do not get into the system.

 **Caution**

Contamination can damage internal components and void the manufacturer's warranty. Take precautions to ensure system cleanliness when removing and installing system lines.

Disassembly

1. With the prime mover off, thoroughly clean all dirt and grime from the outside of the pump.
2. Tag, disconnect, and cap each hydraulic line connected to the pump. As hydraulic lines are disconnected, plug each open port, to ensure that dirt and contamination do not get into the pump.
3. Remove the pump and its auxiliary pump (if applicable) as a single unit.

Be careful, do not damage solenoids and electrical connections when using straps or chains to support the pump.

Inspection

1. Ensure the work surface and surrounding area are clean and free of contaminants such as dirt and grime.
2. Inspect the system for contamination.
3. Look at the hydraulic fluid for signs of system contamination, oil discoloration, foam in the oil, sludge, or metal particles.

Reassembly

1. Before replacing the pump, replace all filters and drain the hydraulic system. Flush the system lines and fill the reservoir with the correct, filtered hydraulic fluid.
2. Fill the pump with clean, filtered hydraulic fluid.
3. Attach the pump to the prime mover. Torque mounting screws according to the manufacturers recommendation.
4. Replace all hydraulic lines. Ensure the charge inlet line is filled with fluid.

EDC Control

Removal

Refer to exploded diagram, next page.

1. Using a 5 mm internal hex wrench, remove the six cap screws (D250).
2. Remove the control module and gasket (D150). Discard the gasket.
3. If necessary, remove orifices (F100) using a 3 mm internal hex wrench. Tag and number them for reinstallation.
4. If screen (D084) is clogged, use a hook to remove retaining ring (D098) and screen. Discard screen and replace with new screen.

Inspection

Inspect the machined surfaces on the control and top of the pump. If you find any nicks or scratches, replace the component.

Minor Repair

Reassembly

Ensure you install dowel pins (D300) in housing before installing control.

1. Install a new gasket (D150).

Proper Screen Orientation

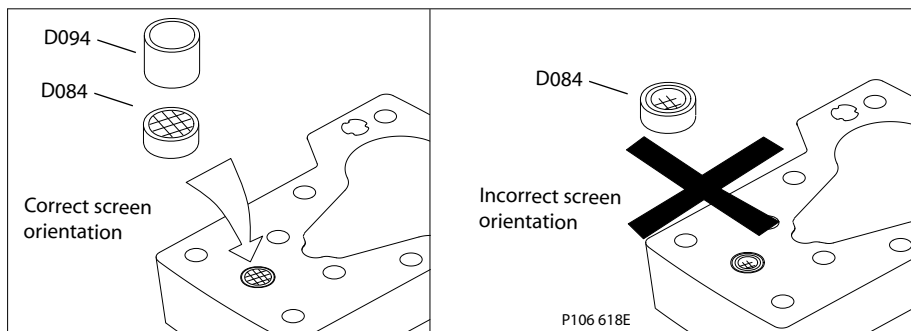

2. If you removed screen (D084), install a new one. Install with the mesh facing outward (see drawing). Install retaining ring (D098).
3. If previously removed, install orifices (F100) using a 3 mm internal hex wrench. Torque to 2.5 N·m [1.8 lbf·ft].
4. Install the control module and six cap screws (D250).
5. Using a 5 mm internal hex wrench, torque the cap screws (D250) to 13.3 N·m [9.8 lbf·ft].

Remove plug on top of control to ensure the swashplate feedback pin is properly positioned in the center of the control module when installing control.

Minor Repair

Control Module and Solenoid Removal/Installation

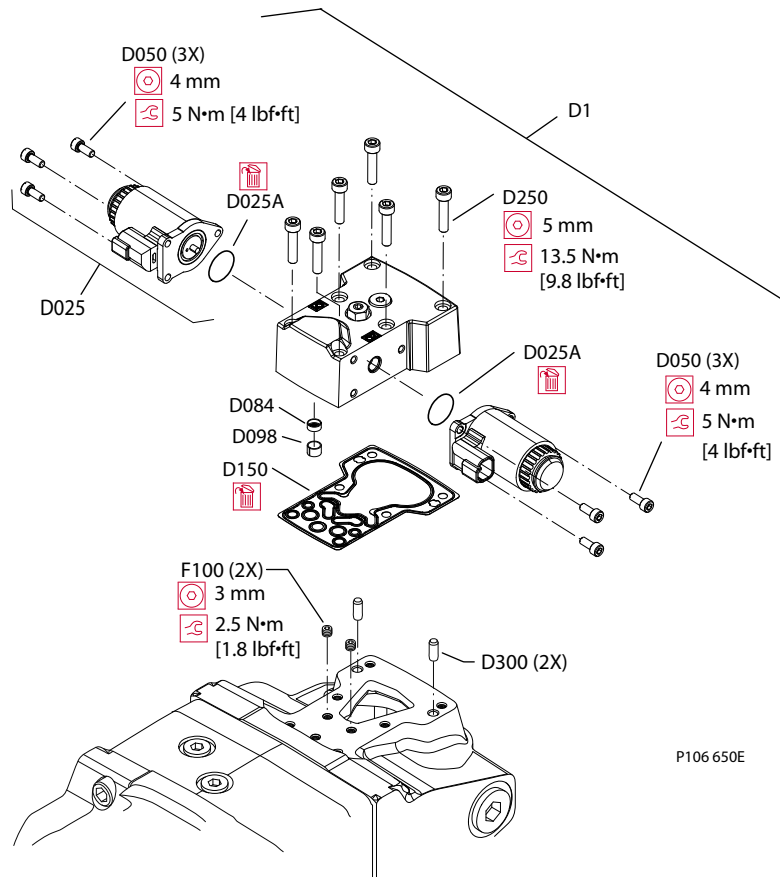

Torque Sequence

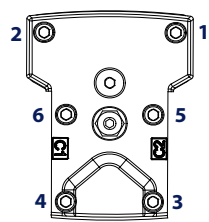

Control Solenoids

Removal

1. Disconnect electrical connection and remove the three cap screws (D050) using a 4 mm internal hex wrench.
2. Remove the solenoid (D025) and O-ring (D025A). Discard the O-ring.
3. If necessary, remove the coil using a 12 point 26 mm socket.

Inspection

Inspect the machined surface on the control. If you find any nicks or scratches, replace the component.

Minor Repair

Reassembly

1. Lubricate new O-ring (D025A) using petroleum jelly and install.
2. Install solenoid with three cap screws (D050) using a 4 mm internal hex wrench. Torque screws to 5 N·m [4 lbf·ft].
3. Install coil using a 12 point 26 mm socket. Torque coil nut to 5 N·m [3.7 lbf·ft].
4. Reconnect electrical connections and test the pump for proper operation.

Automotive Control

Removal

1. Drain pump completely before removing control. Disconnect and remove wiring (D640).
2. Fabricate a special tool to remove two plastic plugs (D610). See drawing below for tool dimensions. Push down on plug and turn 45 degrees counterclockwise. Discard plugs.

Wax seals will be destroyed when the plugs are removed. Do not damage the housing in the plug sealing area.

3. Use a 5 mm internal hex to remove two screws (D674). Remove shield (D672).
4. Use a 5 mm internal hex to remove six screws (D250). Remove control from pump.
5. Remove and discard gasket (D150).

Alignment pins are pressed into control. Do not remove them.

6. If necessary, use a 3 mm internal hex to remove orifices (F00A, F00B) from housing. Tag each orifice for reinstallation. Each orifice may be a different size.
7. If it is necessary to remove the screens, drill out screen retention ring (D098) and remove and discard screen (D084). Note screen orientation for reassembly.

Warning

Do not allow metal fragments to fall into control housing. This may cause erratic pump operation.

Drill Out Retention Ring

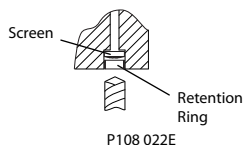

Minor Repair

Remove Control

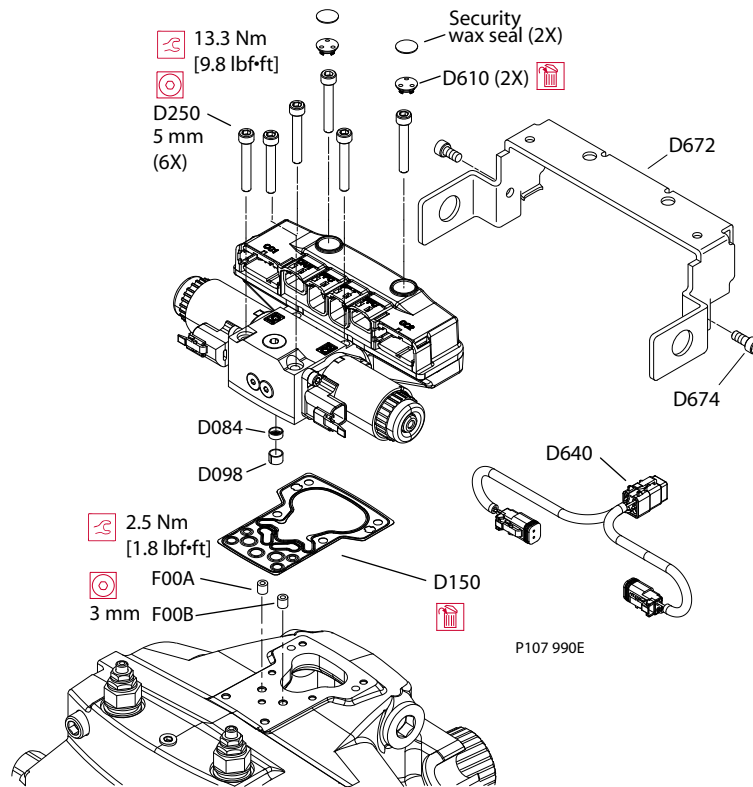

Special Tool

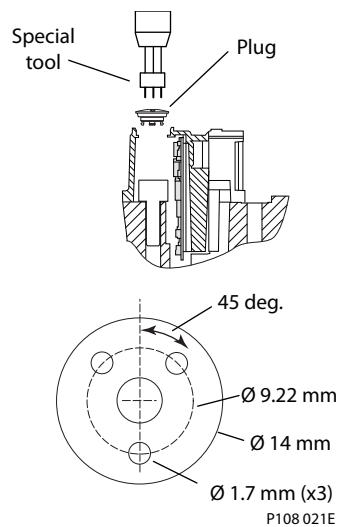

Inspection

Inspect machined surfaces on control and pump housing. Inspect plastic PC board housing and its sealing areas. If any damage is found, replace damaged components.

Controls are available as a complete unit. Do not disassemble the control.

Minor Repair

Assembly

1. If previously removed, install new screen (D084) in original orientation. Press in new retention ring (D098).

Be sure screen will not move axially in bore after retention ring is installed.

Warning

Failure to install screen will result in erratic pump operation.

Proper Screen Orientation

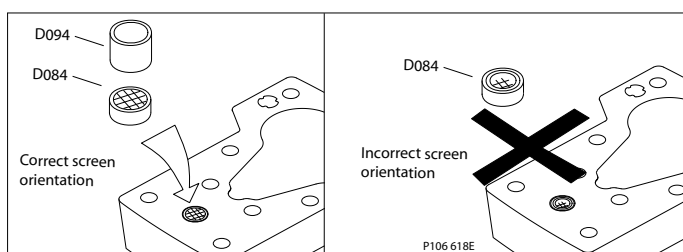

2. If previously removed, use a 3 mm internal hex to install orifices (F00A, F00B) in original orientation. Torque to 2.5 N•m [1.8 lbf•ft].
3. Install new gasket (D150) to bottom of control.

If pump has been rebuilt or a new control is being installed, control software must be recalibrated. Refer to H1-Automotive Control User Manual 70012797 for recalibration instructions.

4. Install control on pump. Use a 5 mm internal hex to install six screws (D250). Torque to 13.3 N•m [9.8 lbf•ft]. Follow torque sequence shown on page 43.

Do not damage the plastic housing in the plug sealing area when installing the screws.

5. Connect wiring (D640).
6. Use the special tool to install new plastic plugs with O-rings (D610). Press plugs in and turn 45 degrees clockwise.

If control will continue to be under warranty, install new sealing wax of a different color (original wax is blue). Pumps without sealing wax installed will not be warrantied.

7. Install protection bracket (D672). Install screws (D674). Torque to 5 N•m [3.7 lbf•ft].

Bearing and Shaft Replacement

The input shaft, seal, and front bearing are serviceable without disassembling the entire pump. Orient the pump on the work surface so the shaft is pointing up.

Removal

1. Using a snap-ring pliers, remove the outer snap-ring (J200).
2. Puncture the seal (J250) and use a slide-hammer type puller to remove the seal. Discard the seal.

Caution

Do not damage the housing bore, shaft or bearing when removing the seal.

3. Use a press or gear puller to press down on the shaft. Using a snap-ring pliers, remove the inner snap-ring (J200).
4. Remove the shaft (J100) and bearing (J150) from the pump. It may be necessary to tap the shaft to dislodge it from the internal pump components. After you remove the shaft, take care not to move or jar the pump. Reassembly can be difficult if the internal components move while the shaft is out.

Minor Repair

- Remove snap-ring (J300). Press bearing (J150) from shaft.

Inspection

Inspect the shaft and bearing for wear, scratching and pits. Rotate the bearing and feel for roughness. Replace damaged components.

Reassembly

- Press bearing (J150) on shaft. Install snap-ring (J300).
- Install the shaft/bearing assembly into the pump. Rotate the shaft to align it with the block and charge pump splines. Press down on the shaft and replace the inner snap-ring (J200).
- Cover end of the shaft with an installation sleeve to protect the seal during installation. Lubricate the seal. Tap on the seal replacing tool or an appropriate deep-socket to press in the seal. Remove the protective cover. Refer to [Specialized tools](#) for installation sleeve and seal installation tool part numbers and dimensions.
- Install the remaining snap-ring.

Shaft Assembly

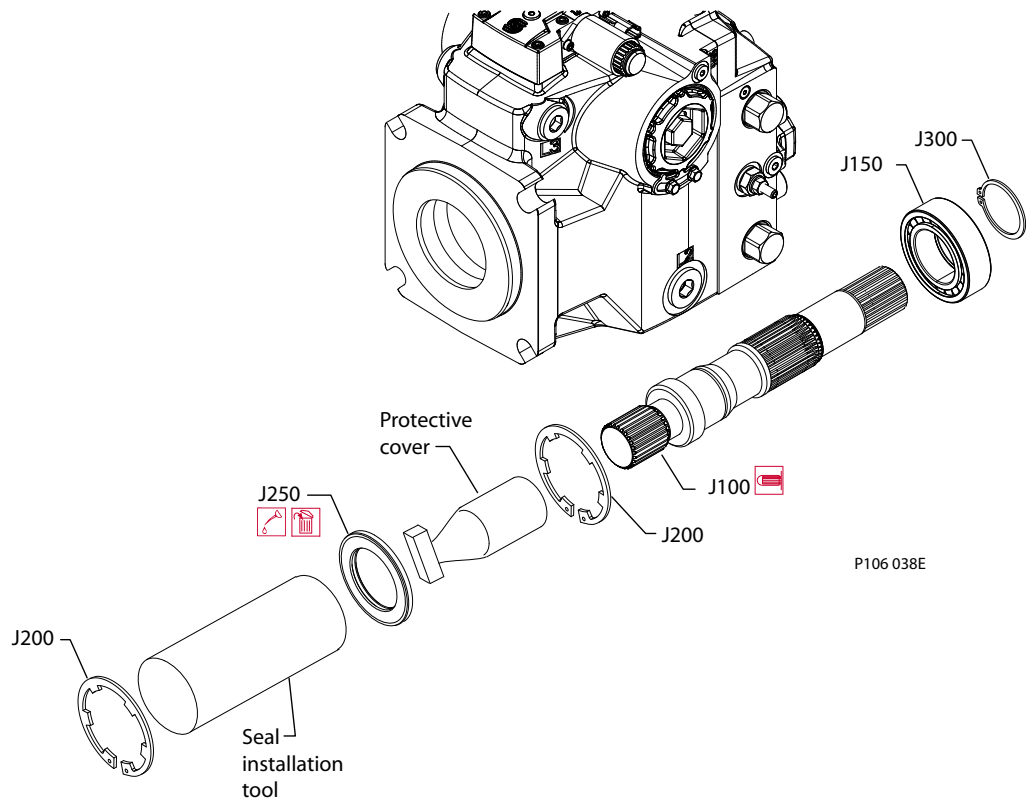

Minor Repair

Seal Installation Tool

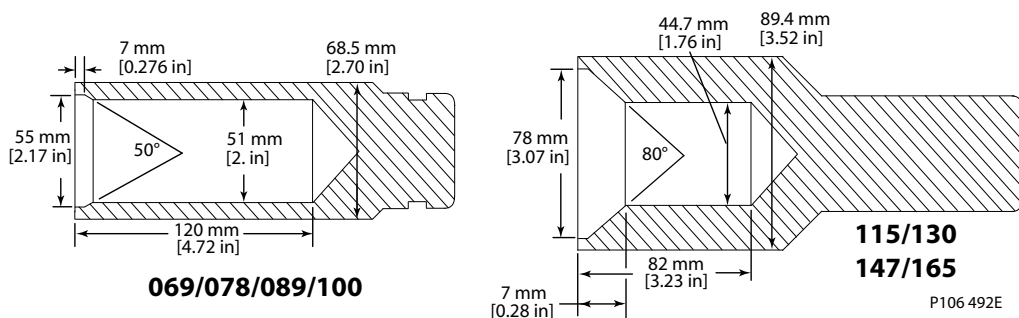

External Filter Replacement

Removal

1. With the prime mover off, hold the filter (T150) in place, and remove the plug (T015) using a 17 mm wrench.
2. Remove the filter.
3. Remove and discard the seal (T045) and O-ring (T035).

Inspection

Inspect the plug and sealing surfaces in the filter bracket. Replace any damaged components.

Reassembly

1. Install new seal (T045) and O-ring (T035) on plug.
2. Apply hydraulic fluid to the O-ring and seal for lubrication. Insert the plug into the bracket.
3. Use a 24 mm wrench to hold the plug in place and install the replacement filter. Hand tighten filter till it contacts O-ring, then tighten 1/2 turn further.
4. Start the prime mover. Cycle the pump through normal machine operation and check for leaks.

Minor Repair

External Filter Replacement

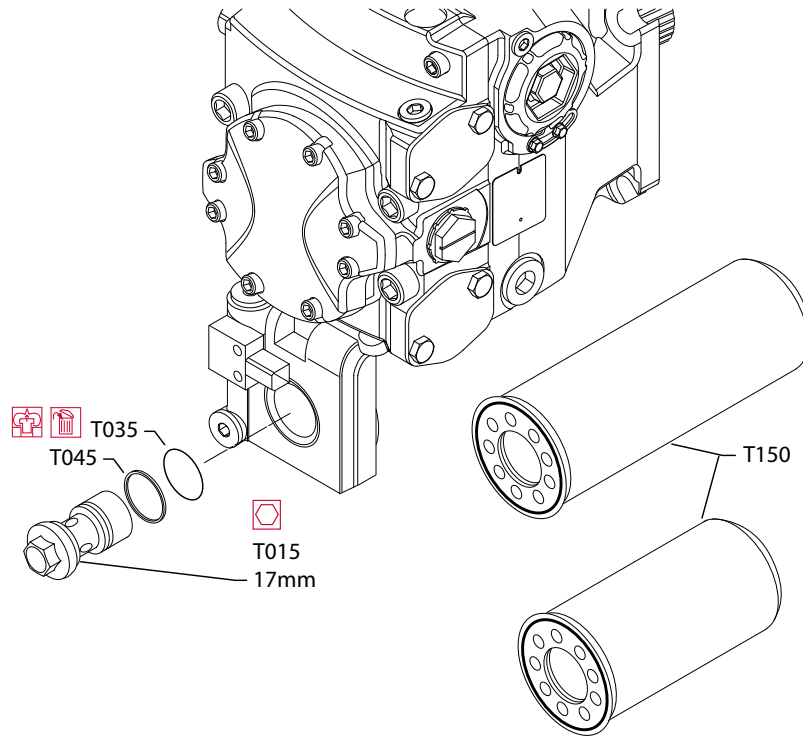

P106 035E

Filter Bypass Valve and Filter Bypass Switch

Removal

1. Remove three screws (T250) using a 6mm internal hex wrench.
2. Remove the filter adapter (T010) and gasket (T350). Discard the gasket.
3. Use an 8 mm internal hex wrench to remove plugs (T025).
4. Remove and discard O-rings (T040).
5. Remove spring (T030), and poppet (T020).
6. If necessary, use a 3 mm internal hex wrench to remove cap screws (T300) and bypass switch (T200).

It is not necessary to remove switch (T200) unless it is being replaced.

Inspection

1. Inspect poppet (T020) for bending or damage. Replace if necessary.
2. Inspect spring (T030) for cracks or warpage. Replace if necessary.
3. Inspect sealing surface of filter adapter (T010) for scratches or damage. Resurface or replace scratched or damaged part.

Reassembly

1. Lubricate and replace O-ring (T040) on plug (T025).
2. Install poppet (T020), spring (T030), and plug (T025). Torque to 18 N•m [13 lbf•ft].
3. If replacing bypass switch, install and torque 3 mm cap screws (T300) to 1.4 N•m [1 lbf•ft].
4. Install adapter assembly (T010) using new gasket (T350) to pump. Install cap screws (T250) using a 6mm internal hex wrench. Torque to 32 N•m [24 lbf•ft].

Minor Repair

Filter Adapter Replacement

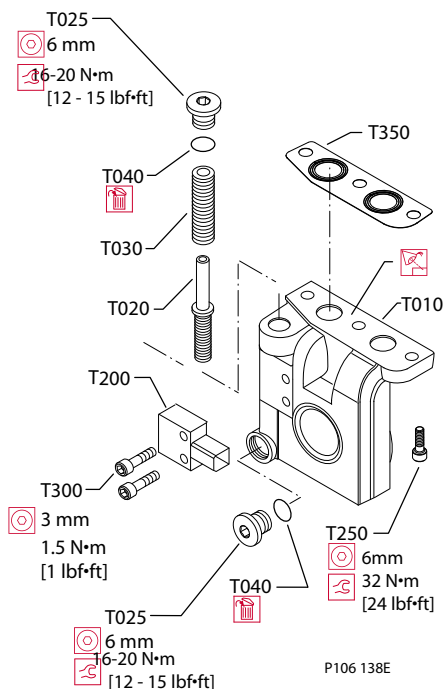

Charge Pump

If the pump has an auxiliary pump attached, remove the auxiliary pump and coupling before removing the auxiliary pad.

Charge pump removal (removable auxiliary pad/cover)

1. Using a 10 mm internal hex wrench, remove cap screws (K400).
2. Remove charge pump cover or auxiliary pad (K100) and gasket (K150). Discard the gasket. Alignment pins (G450) may remain in cover or endcap.
3. Remove thrust washer (K500). Note its orientation. Coated side is towards charge pump coupling (K200).
4. Remove pressure-balance plate (S200) with seal (S300). Note orientation of plate and seal. Discard seal.
5. Remove charge pump coupling (K200).
6. Remove charge pump gearset (S100) and outer ring (S150).
7. Remove valve plate (S250) with seal (S300). Note orientation of valve plate and seal. Discard seal (S300).

Minor Repair

Charge Pump Removal/Installation

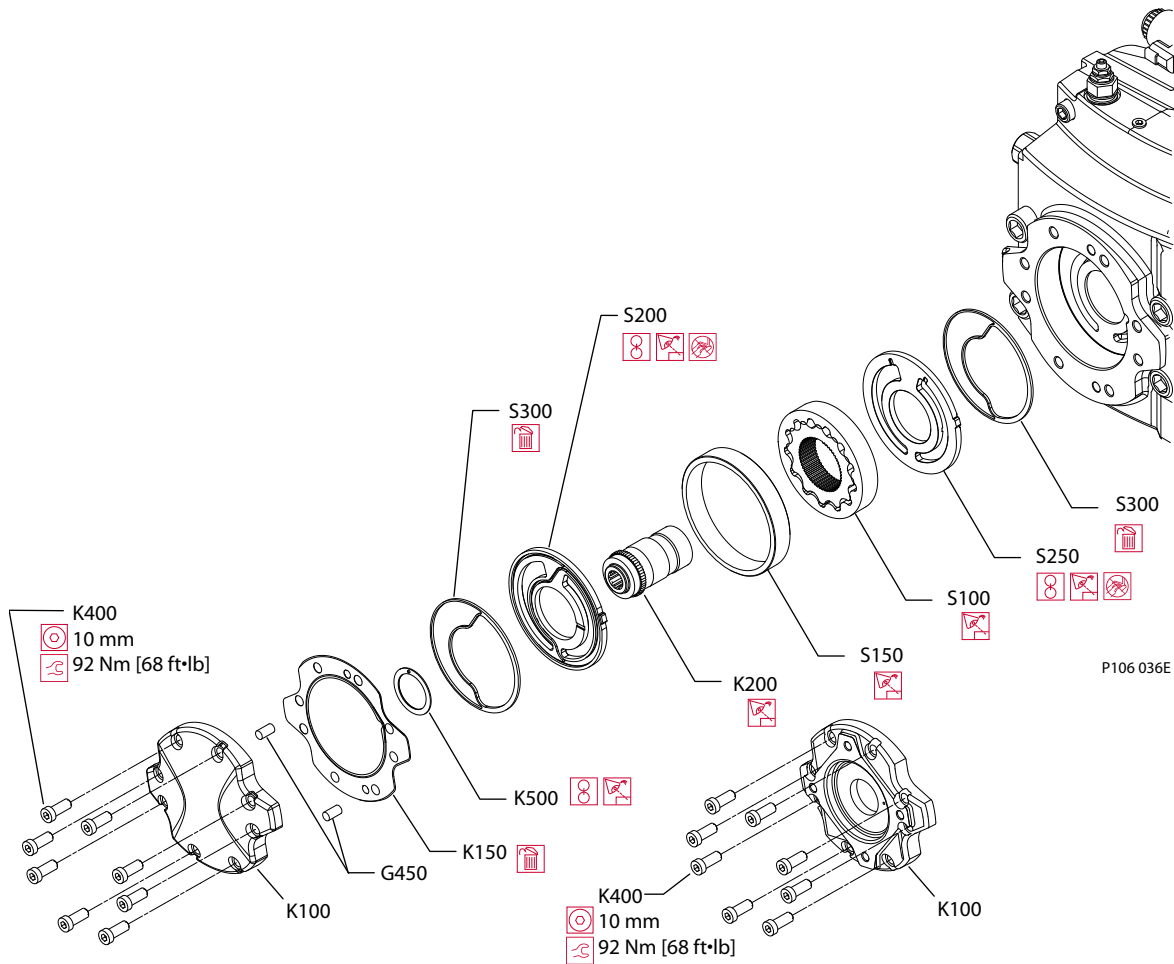

Charge Pump Removal (integrated auxiliary pad)

1. Remove auxilliary pump and O-ring (K250). Discard O-ring.
2. Remove charge pump cover screws (K450) and charge pump cover (K550).
3. Remove thrust washer (K500). Note its orientation. Coated side is towards charge pump coupling (K200).
4. Remove pressure-balance plate (S200) with seal (S300). Note orientation of valve plate and seal. Discard seal (S300).
5. Remove charge pump coupling K200).
6. Remove charge pump gearset (S100) and outer ring (S150).
7. Remove valve plate (S250) with seal (S300). Note orientation of valve plate and seal. Discard seal (S300).

Minor Repair

Cover (K100) Torque Sequence

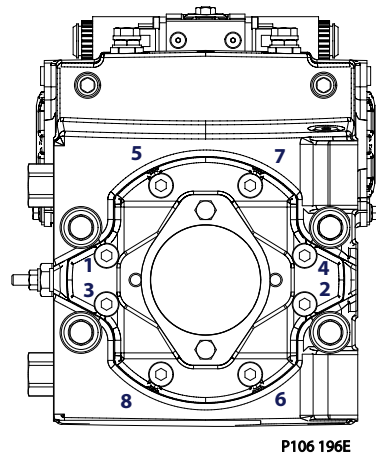

P106 196E

Cover (K550) Torque Sequence

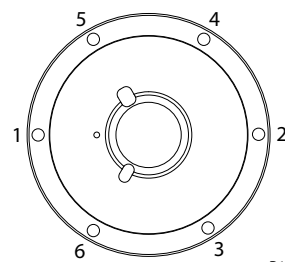

P106 659E

High Pressure Relief Valves (HPRV)

Removal

Using a hex wrench shown in the table below, remove the HPRVs (L150). Remove and discard the O-rings (L060) and backup rings (L068).

Inspection

Inspect the sealing surfaces in the pump for nicks or scratches. Check the valves for damage. Replace any damaged components.

Reassembly

1. Lubricate and install new backup rings (L068) and O-rings (L060).
2. Install HPRVs. Torque to the value in the table below.
3. Operate the vehicle/machine through full range of controls to ensure proper operation. Check for leaks.

Minor Repair

HPRVs

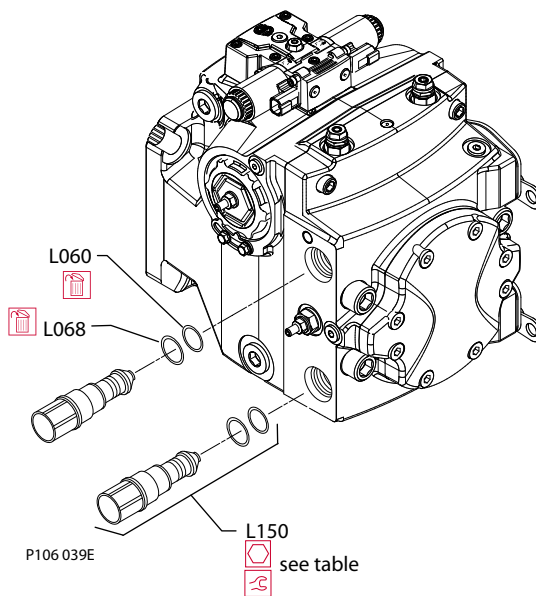

HPRV Wrench Size and Torque Values

Displacement	Wrench size and torque
069/078/089/100	22 mm - 70 N•m [52 lbf•ft]
115/130/147/165	30 mm - 110 N•m [81 lbf•ft]

Charge Pressure Relief Valve

Replace the charge pressure relief valve (V010) as a complete unit. Do not attempt to repair the internal components of the valve. Torque to 52 N•m [38 lbf•ft]

See Charge Pressure Relief Valve djustment, page 31, for adjustment instructions.

Removal

Using a 22 mm wrench, remove the charge pressure relief valve (V010). Discard seal (V024).

Inspection

Inspect the sealing surfaces of the pump for nicks or scratches.

Reassembly

1. Lubricate and install new seal (V024).
2. Install the charge pressure relief valve. Torque to 52 N•m [38 lbf•ft].
3. Operate vehicle/machine through full range of controls to ensure proper operation.

Minor Repair

Charge Pressure Relief Valve

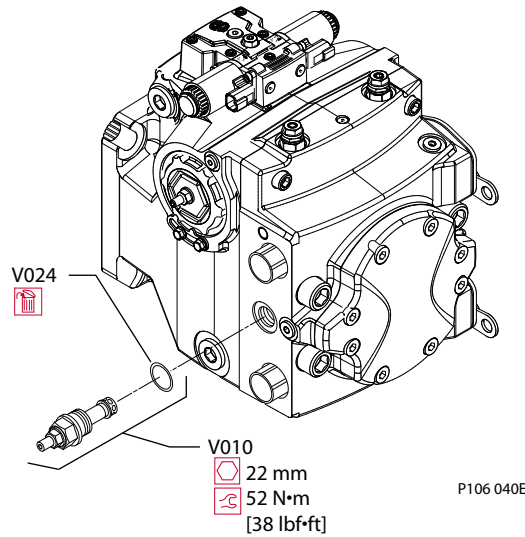

PressureLimiter Valve Replacement

Replace the pressure limiter valve as a complete unit. Do not attempt to repair individual components. See Pressure Limiter Adjustment, page 32, for adjustment instructions.

Removal

Using a 22 mm wrench, remove the pressure limiter valve (L100). Discard O-ring.

Inspection

Inspect the sealing surfaces of the pump for nicks or scratches.

Reassembly

1. Install new O-ring. Lubricate O-ring with petroleum jelly.
2. Replace pressure limiter valve. Torque to 70 N·m [52 lbf·ft].
3. Operate pump at full range of controls to ensure proper machine operation.

Pressure limiter is available as complete unit only. O-ring is available separately.

Minor Repair

Pressure Limiter

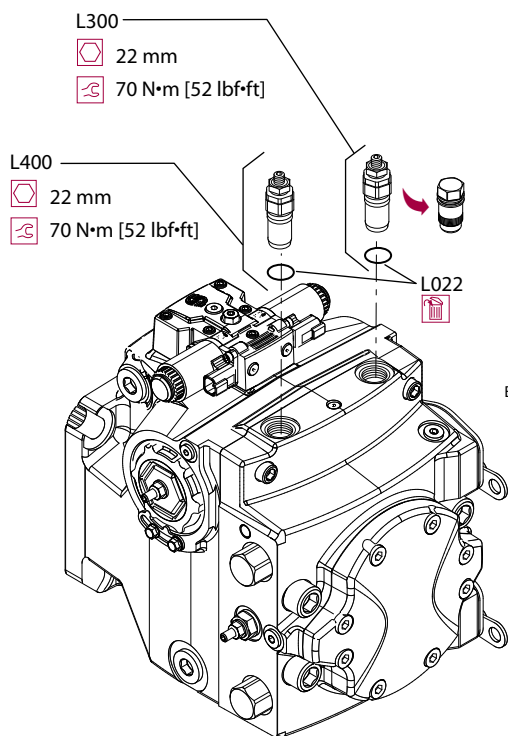

Torque Chart
Fastener Size and Torques
069/078/115/130/147/165

Item	Fastener	Wrench size	Torque
D015	Neutral adjust screw	4 mm internal hex	NA
D050	Coil mounting bolt	4 mm internal hex	8 N•m [6 lbf•ft]
D060	Neutral adjust locking nut	13 mm	10 N•m [7 lbf•ft]
D200	Swash plate feedback pin (not shown)	13 mm deep well socket	25 N•m [18 lbf•ft]
D250	Electric control mounting bolt	5 mm internal hex	13.3 N•m [9.8 lbf•ft]
E350	Servo can locking bolt	10 mm	14 N•m [10 lbf•ft]
T015	Filter mounting bolt	17 mm	NA
T025	Filter adapter gage plug	6 mm internal hex	18 N•m [13 lbf•ft]
V010	Charge pressure cartridge	22 mm	52 N•m [38 lbf•ft]
V020	Charge pressure adjusting screw	4 mm internal hex	NA
V022	Charge pressure locking nut	13 mm	12 N•m [9 lbf•ft]

069/078/089/100

Item	Fastener	Wrench size	Torque
K400	Rear cover/Aux pad mounting bolt	10 mm internal hex	100 N•m [74 lbf•ft]
K450	Charge Pump Cover Screw	5 mm internal hex	10 N•m [7 lbf•ft]
L010	Pressure limiter adjust screw	8 mm	NA
L012	Pressure limiter cartridge	14 mm	30 N•m [22 lbf•ft]
L024	Pressure limiter locking nut	14 mm	20 N•m [15 lbf•ft]
L150	High pressure relief valve	22 mm	70 N•m [52 lbf•ft]

115/130/147/165

Item	Fastener	Wrench size	Torque
K400	Rear cover/Aux pad mounting bolt	10 mm internal hex	100 N•m [74 lbf•ft]
K450	Charge Pump Cover Screw	5 mm internal hex	10 N•m [7 lbf•ft]
L010	Pressure limiter adjust screw	5 mm internal hex	NA
L012	Pressure limiter cartridge	22 mm	70 N•m [52 lbf•ft]
L024	Pressure limiter locking nut	17 mm	20 N•m [15 lbf•ft]
L028	Pressure limiter plug (special)	19 mm	68 N•m [50 lbf•ft]
L150	High pressure relief valve	30 mm	110 N•m [81 lbf•ft]

Plug Size and Torques
069/078/115/130/147/165

Item	O-ring plug	Wrench size	Torque
B015	7/16 - 20	3/16 mm internal hex	12 N•m [9 lbf•ft]
B020 (069/078)	7/8 - 14	3/8 internal hex	70 N•m [52 lbf•ft]
B020 (147/165)	1-1/16 - 12	9/16 internal hex	70 N•m [52 lbf•ft]

Torque Chart

069/078/115/130/147/165 (continued)

Item	O-ring plug	Wrench size	Torque
B035 (069/078)	1 1/16 - 12	9/16 internal hex	70 N•m [52 lbf•ft]
B035 (147/165)	1 5/16 - 12	5/8 internal hex	150 N•m [110 lbf•ft]
D065	7/16 - 20	3/16 internal hex	12 N•m [9 lbf•ft]
G250	9/16 - 18	1/4 internal hex	24 N•m [18 lbf•ft]
G300	9/16 - 18	3/16 internal hex	24 N•m [18 lbf•ft]
G302	5/16 - 24 UNF	1/8 internal hex	5 N•m [4 lbf•ft]

Fasteners and Plugs

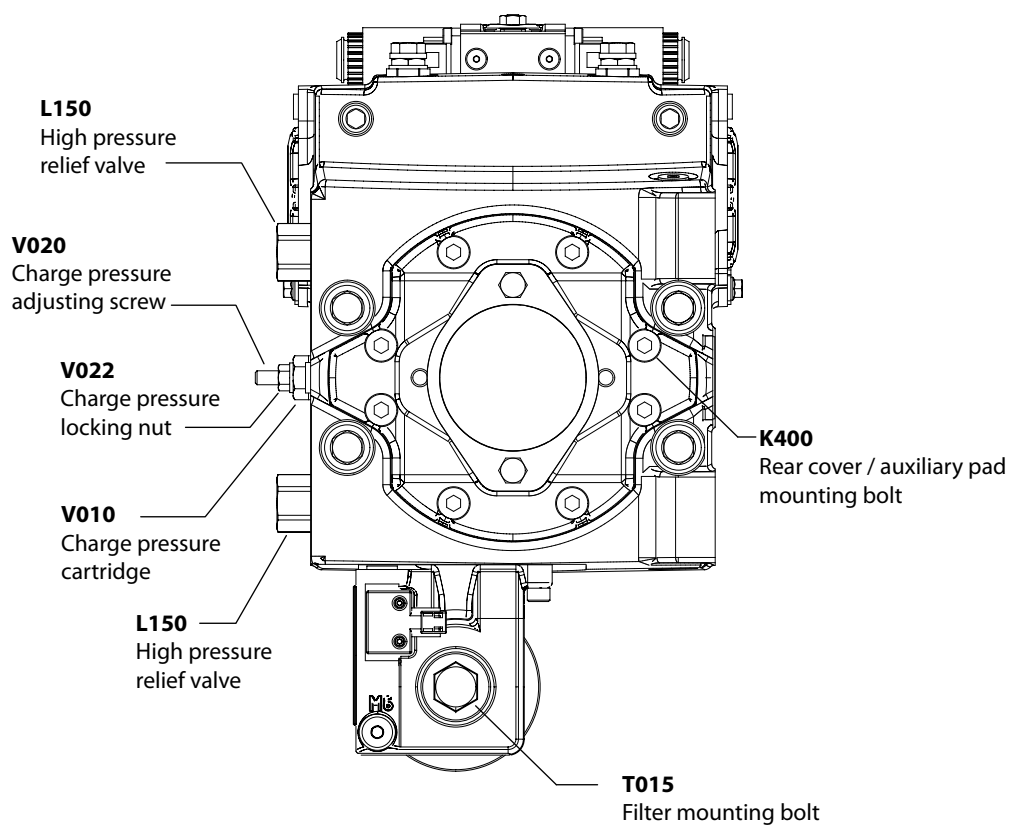

P106 066E

Torque Chart

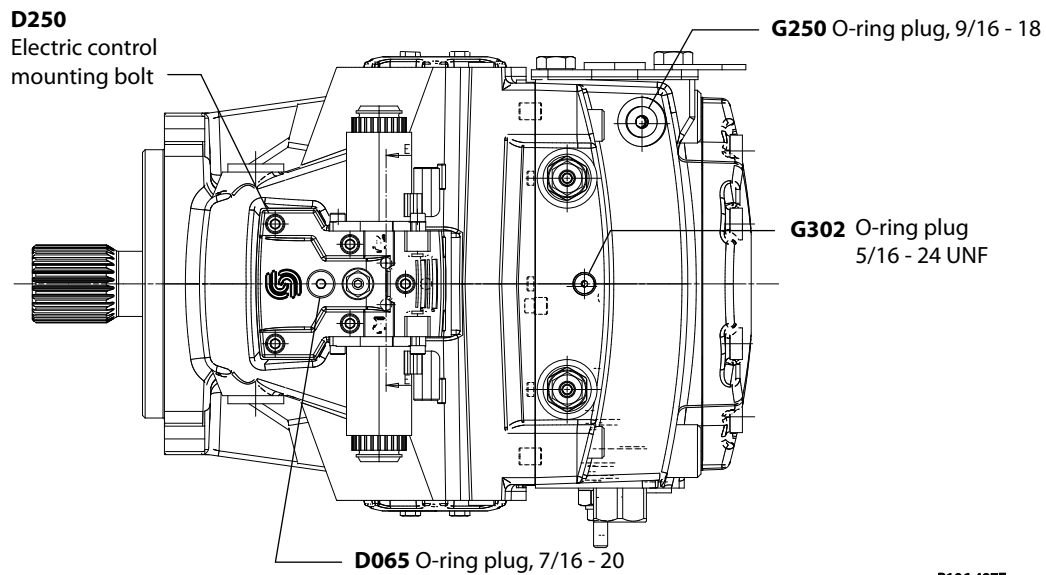
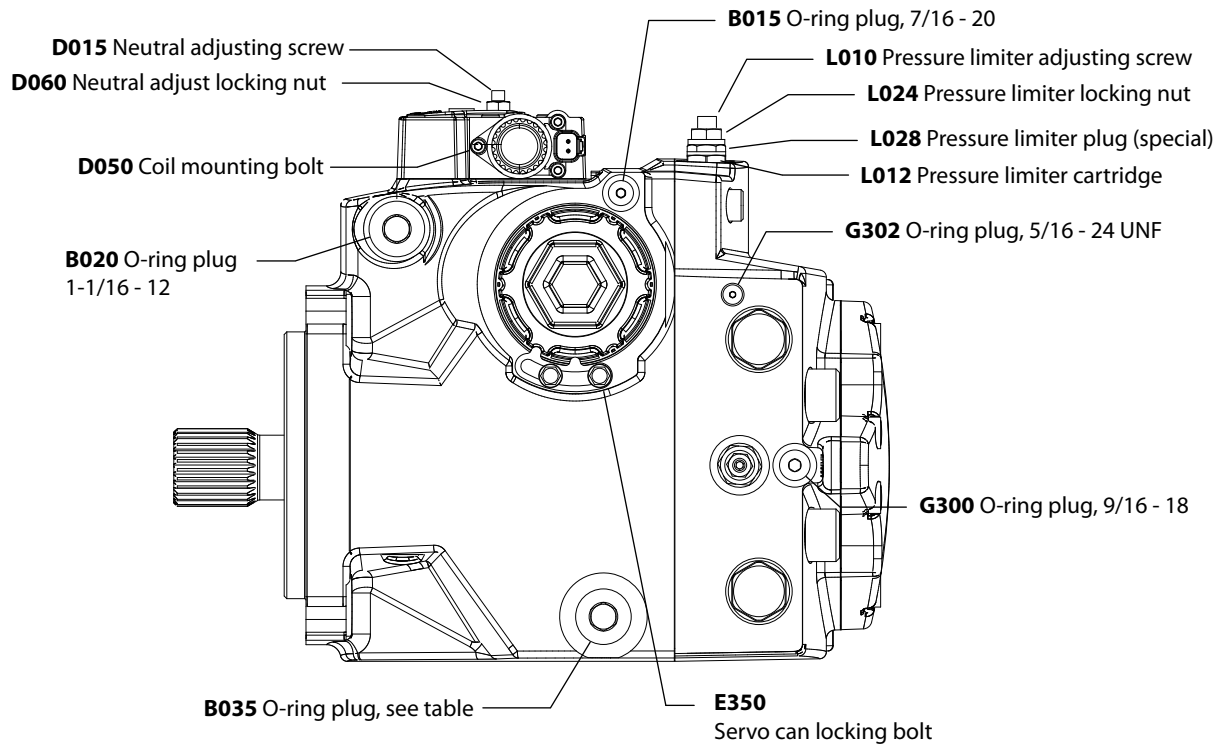

P106 497E



Comatrol

www.comatrol.com

Schwarzmueller-Inverter

www.schwarzmueller-inverter.com

Turolla

www.turollaocg.com

Valmova

www.valmova.com

Hydro-Gear

www.hydro-gear.com

Daikin-Sauer-Danfoss

www.daikin-sauer-danfoss.com

Local address:

**Danfoss
Power Solutions US Company**
2800 East 13th Street
Ames, IA 50010, USA
Phone: +1 515 239 6000

**Danfoss
Power Solutions GmbH & Co. OHG**
Krokamp 35
D-24539 Neumünster, Germany
Phone: +49 4321 871 0

**Danfoss
Power Solutions ApS**
Nordborgvej 81
DK-6430 Nordborg, Denmark
Phone: +45 7488 2222

**Danfoss
Power Solutions
(Shanghai) Co., Ltd.**
Building #22, No. 1000 Jin Hai Rd
Jin Qiao, Pudong New District
Shanghai, China 201206
Phone: +86 21 3418 5200

Danfoss can accept no responsibility for possible errors in catalogues, brochures and other printed material. Danfoss reserves the right to alter its products without notice. This also applies to products already on order provided that such alterations can be made without changes being necessary in specifications already agreed.. All trademarks in this material are property of the respective companies. Danfoss and the Danfoss logotype are trademarks of Danfoss A/S. All rights reserved.